

CONTRACT FDA-73-32

FINAL REPORT

OCTOBER 1975

STRENGTH CHARACTERISTICS
OF U.S. CHILDREN
FOR PRODUCT SAFETY DESIGN

CLYDE L. OWINGS, M.D., Ph.D.
Department of Pediatrics and Communicable Diseases
Department of Electrical and Computer Engineering

DON B. CHAFFIN, Ph.D.
Department of Industrial and Operations Engineering

RICHARD G. SNYDER, Ph.D.
Biomedical Department, Highway Safety Research Institute
Department of Anthropology

RICHARD H. NORCUTT, M.S. (Bioengineering)
Department of Pediatrics and Communicable Diseases

THE UNIVERSITY OF MICHIGAN
ANN ARBOR, MICHIGAN 48104

Prepared for:

THE CONSUMER PRODUCT SAFETY COMMISSION
5401 West Bard Avenue Room 100
Bethesda, Maryland 20207

ACKNOWLEDGEMENTS

This study was accomplished through the cooperation of many individuals and organizations during the last thirty-one months. The authors acknowledge with pleasure and gratitude the particular contributions of some.

The major portion of the data reported in this study was obtained under the careful supervision of Kathie Y. Lloyd, Linda J. Brown, Susan M. Kornfield, and Susan S. Anderson. During the early stages of this investigation, Margaret G. Abdelnour and Ann Russ Desautels assisted in the collection of data. Appreciation is also extended to Maggie Lloyd.

During the early design phase of the project, James A. Foulke and Dr. John Gesink worked in conjunction with Ronald Anderson and Don Ellinger on design of equipment for initial measurements. Steven Enzer helped with electrical fabrication.

The statistical design of the project was under the general supervision of Dr. M. Anthony Schork, with assistance from Robert Abbott. Mr. Michael Grady served as systems analyst for the project and wrote a major portion of the computer program. Arun Garg assisted in developing the Biomechanical Model.

Dr. Lawrence W. Schneider provided consultation and coordination and Ginny Owings supervised the administrative and clerical aspects of the project. William Graham produced the illustrations.

Consultation on the linkage measurements and helpful suggestions were received from Dr. John McConville of Webb Associates.

Respectful acknowledgement is gratefully extended to the technical monitors from The Consumer Product Safety Commission

who have supervised and contributed greatly to the performance of this study: Mrs. Elaine Besson, Mr. John K. O'Connor, and Mr. Donald T. Van Houten.

We most sincerely appreciate the contribution of over 500 children who performed the exertions recorded in this study, and most particularly the cooperation of their parents.

in the test fixture so that the anatomic position was defined.

A biomechanical computer model of a child was designed and has undergone preliminary testing. It allows the data for isometric strength to be used to estimate strength capability in various anatomic positions.

TABLE OF CONTENTS

	Page
ACKNOWLEDGEMENTS.....	i
SUMMARY.....	iii
TABLE OF CONTENTS.....	iv
LIST OF FIGURES.....	v
1.0. INTRODUCTION.....	1
1.1. Background.....	1
1.2. Objectives and Scope.....	9
2.0 METHODS AND TECHNIQUE.....	10
2.1. Design of the Study.....	10
2.2. Design of Transducers.....	10
2.3. Data Acquisition System.....	11
2.4. Initial Measurements.....	12
2.5. Preliminary Experiments.....	13
2.5.1. Inertial Effects.....	13
2.5.2. Joint Position Interaction.....	14
2.5.3. Motivation.....	15
2.6. Strength Criteria and Reproducibility.....	16
2.7. Portable Strength Chair.....	19
2.7.1. Strength Chair Design.....	20
2.7.2. Grip and Pinch Transducer.....	26
2.7.3. Amplifiers.....	27
2.7.4. Strength Chair Function.....	29
2.7.5. Calibration.....	39
2.7.6. Summary.....	42
2.8. Data Acquisition and Display.....	42
2.9. Population Survey.....	46
2.9.1. Testing Procedure.....	51
2.9.2. Motivation.....	56
2.10. Data Reduction.....	59
3.0. RESULTS.....	64
3.1. Description of Data Presentation.....	64
3.2. Strength Measurements.....	65
3.2.1. Interpretation.....	65
3.2.2. Index of Data.....	75
3.2.3. Data.....	76
3.3. Linkage Measurements.....	208
3.3.1. Interpretation.....	208
3.3.2. Index of Data.....	212
3.3.3. Data.....	213
4.0. APPENDICES.....	241
4.1. Strength Chair Analysis.....	241
4.2. Sample Data Plots: Strength vs Time.....	245
4.3. Priorities.....	251
4.4. Reduced Data File.....	254
5.0. BIBLIOGRAPHY.....	256
6.0 BIOMECHANICAL MODELING.....	272

LIST OF FIGURES

Figure No.	Title	Page
1.	Complete Measurement System	20
2.	Side View of Chair	21
3.	Front View of Chair	22
4.	Chair Adjusted for 9 Year Old	24
5.	Child in Standard Test Position	25
6.	Gage Position for Wrist Transducer Used to	26
	Measure Pronation/Supination, Flexion/ Extension, and Adduction/Abduction	
7.	Grip and Pinch Transducer	27
8.	Instrumentation Amplifiers at Rear of Chair	28
9.	Diagram of Grip Transducer	30
10.	Diagram of Arm Fixture	32
11.	Diagram of Leg Fixture	34
12.	Diagram of Torso Fixture	35
13.	Chair in Calibration Position	40
14.	Attachment of Calibration Weights	41
15.	Graphics Display: Primary Channel Plotting	44
16.	Graphics Display: All Channels Plotting	45
17.	Information Sheet	48
18.	Questionnaire	49
19.	Consent Form	50
20.	Scatter Plot of Data with Fourth Order	62
	Polynomial Fit	
21.	Scatter Plot of Data with 3rd, 4th, and 5th....	63
	Order Polynomial Fit	
22.	Anatomic Planes, Axes, and Directions	69
23.	Anatomic Terms	70
24.	Reproducibility of Linkage Measurements	210

1. INTRODUCTION

1.1. Background

A child's strength is one of the many factors which modulate his day to day activities; important because it gives him the capacity to get into dangerous situations and at the same time confers upon him the potential to escape hazards.

As a child grows, he develops muscular control and precision of movement while developing increased muscle strength. Therefore, age-correlated information about the strength capability of children is necessary for providing environmental safeguards. Although it is probably impossible to render any environment completely "safe" for children, society has an obligation to insure that products specifically intended for children are not hazardous.

In attempting to meet this obligation, the need for specific data became apparent. This study was undertaken to provide a systematic, large scale study of the strength of children between the ages of two and ten years. The resulting data may serve as a basis for the writing of regulations and specifications governing the design and manufacture of products intended for childhood use.

Human strength has been a field of great interest to physicians, anthropologists, human factors engineers, product designers, coaches, athletes, and physical educators. Although most people have an intuitive understanding of the meaning of strength, there is wide disagreement in the literature over the correct way to quantitatively measure strength. Part of this disagreement results

from the different needs and uses for which data are collected. Investigators in the field of physical education have been concerned with gross measurements of muscular strength, and in assessing the degree of "physical fitness". Such tests have frequently involved complex biomechanical actions such as sit-ups, push-ups, pull-ups, and other measures of strength, stamina, and physical endurance. Human factors engineers have been more concerned with testing specific strengths and determining work capability.

A review article by Kramer(111) contains a critique of the strength measurement literature to date and outlines some of the pitfalls which are encountered in the measurement of strength. He proposes the following definition of strength: "Strength is the maximal force muscles can exert isometrically in a single voluntary effort." The dimensions of strength are force or torque exerted over a specified period of time. An isometric contraction of a muscle or muscle group means that tension is developed in the muscle without the length of the muscle being altered. This implies that there will be no movement of the body parts involved in an isometric strength exertion. Thus the concept of work in the strict mechanical sense is not directly applicable to the effort expended in holding a weight motionless.

Clearly, different factors are involved in the ability to maintain an exertion over a period of time from those required to effect a brief exertion. The ability to perform such a prolonged exertion is called endurance and is influenced mainly by fatigue which is caused by such factors as the metabolic cycle of the active muscle, the accumulation of waste products from metabolism,

the adequacy of blood supply to the muscle, etc. Thus, the ability to lift an object depends upon strength while the ability to hold that object in a location for several minutes involves endurance.

A concentric exertion is one in which the muscle develops tension at the same time that its length is decreasing. An eccentric exertion is one in which the muscle develops tension at the same time that its length is increasing. Both such measurements of muscular function imply a dynamic activity and are complex from both the theoretical and practical viewpoints.

Isotonic measurement of strength has been mentioned widely in the literature, but it is much easier to define than to measure. An isotonic exertion is one in which the tension within the muscle remains constant while the length of the muscle varies. Under most circumstances, it is almost impossible to measure or accurately estimate the tension developed within a muscle as it contracts, if there is, at the same time, lengthening or shortening of the muscle.

Most of the strength studies reported in the literature have used isometric testing for a variety of reasons. It is safer to perform isometric testing, since the subject can be protected from the unexpected development of large dynamic forces. The equipment necessary for isometric muscle testing is more generally available and can be calibrated in standard units in a straightforward fashion. In contrast, the equipment available for making measurements of dynamic strength has been extremely difficult to calibrate in absolute units. Although Thistle (1976) has described

a very interesting commercial unit for the assesment of dynamic strength, there is some question about the general applicability of such information and its usefulness in other than a relative context.

Chaffin (30) defines static strength as: "The capacity to produce torque or force by a maximal voluntary isometric muscular exertion." He recommends that strength be tested during an exertion of 4 to 6 seconds with a measuring device which records the average value over the middle 3 seconds of exertion. It is important that the subjects have adequate rest periods so that fatigue does not influence the results of isometric testing. The results of Shawnee (161) and others suggest that a rest of 2 minutes between exertions is appropriate for repetitive testing when approximately 15 tests are to be performed during a single session. In order that strength information may be reasonably interpreted, the body position in which the measurement is taken must be well specified since a slight alteration in this position can change the mechanical advantage available to the individual. The body balance can place a severe limitation on the ability to exert isometric strength and should be considered in interpreting results of strength testing. It is, moreover, important that the population which is being tested be described by age, relevant anthropometric data (such as height and weight), and the state of health; and that the population selection procedure be documented.

In examining the available data, major attention must be focused on the measurement techniques. The cable tensiometer has been widely used in the measurement of strength, particularly by

Clark (37, 39, 47). This device was originally designed for the measurement of tension in aircraft control cables and operates on the principle that a spring-loaded plunger deflects the segment of cable passing through the device in a manner inversely proportional to the tension in the cable. Readout is accomplished with a dial indicator monitoring the movement. Such instruments can be calibrated so that the dial reads in pounds of force but one has the chore of interpreting and evaluating the peak reading by observing the fluctuations of the dial. The experimenter must be in a position to actually observe the indicator during the testing. This limits somewhat the locations in which cable tensiometers may be used. Moreover, there is no permanent record of the exertion, and averaging techniques are difficult to apply to such an admittedly simple device.

The Jamar dynamometer has been used by many investigators for grip testing. The device was, apparently, first described in 1954 by Bechtol (7). It uses adjustable hand spacing together with a sealed hydraulic system which registers in pounds per square inch on an indicator dial. As force increases, an indicator is carried to the highest value reached by the pointer of the dial and remains at the highest value until it is reset. This device can be calibrated with a set of weights to read pounds-force or kilograms-force exerted during the gripping test. Schmidt and Toews (1970) measured over a thousand normal males during pre-employment physicals at a California steel manufacturing plant. The results demonstrated that adult males produced 113.1 pounds force with the dominant hand and 109.6 pounds force with the

non-dominant hand. These values were obtained with a standard deviation of approximately 5.5 pounds force and demonstrate the relatively small differences in strength between the dominant and non-dominant hands.

As has been pointed out by Kramer (111), there is considerable difficulty in interpreting the literature because most articles do not clearly and unambiguously define the method used to yield a strength value. Frequently one may be comparing an average strength value from one report with a peak strength value in the second report.

Motivation and psychological factors play a strong role in modifying the expression of an individual's inherent strength capability. Unfortunately, it is extremely difficult to quantify the degree of enthusiasm and motivation present during an exertion. Ikai and Steinhaus (92) investigated the measured strength during and after hypnosis and found that six out of seven subjects were able to improve their performance. The exception was a trained athlete who never exceeded his initial effort. One must conclude that the innate strength capability of an individual can be modified by a variety of inhibitory influences which may prevent a maximal effort.

One of the major studies of strength measurement in children was done by Krogman (112) for the Closure Committee of the Glass Containers Manufacturers Institute in 1971. Unfortunately, the paper was published without a calibration of the force required to produce a specific level of "pounds per square inch" on the instrumentation used. The data contained within the study, which

includes measurement of grip, palm push, wrist turning, thumb opposability, and bite are useful mainly in the relative values shown between the various age groups. This series of approximately 500 children did reveal that boys appear to be slightly stronger than girls but it is questionable whether this is a truly statistically significant variation. There was an attempt to evaluate racial differences between White and Negro children, but the conclusion: "There does not appear to be any racial difference", was not subjected to statistical tests.

A very nicely executed study of the strength capabilities of children between the ages of 2 and 6 years was carried out by Brown, Buchanan, and Mandel of the National Bureau of Standards, (12). The equipment used in this study was previously described by Toner and Brown (181), and consisted of devices for measuring hand push, pull, and twist together with a commercially available hand grip dynamometer. Their instrumentation included a continuous readout of force or torque on a strip chart recorder. With this equipment, studies were done in the age group between 2 and 6 years. Approximately 50 children were included in each age/sex group for a total of over 500 children. This population included greater than 20% Black children. The tests were administered by allowing the child to pull or push on a lever. He could observe colored lights and the number of colored lights illuminated was proportional to the force he exerted. The child was allowed to assume whatever body position he desired and a variety of different knob sizes and handle shapes were used. The children were also tested for one-handed and two-handed grip on the dynamometer.

The study revealed that the maximum and mean strength capabilities were greater for boys than for girls in all ages tested, although the absolute magnitude of the difference was rather small. For most tests, the standard deviation appeared to increase with age as did the value of the strength measured.

There are at least two philosophical approaches to measuring strength. The first is to design instrumentation which measures strength capability for a specific task. This measurement method gives precise data which has limited generality. Frequently a small alteration in the anatomic position of an individual during strength testing will drastically alter the measurement of strength capability. Therefore, one has difficulty in extrapolating the data to different tasks which require different anatomic configurations, and each new task may require a new experimental measurement. The second approach is to measure a limited set of strength capabilities in standard anatomic positions. These data can be utilized in biomechanical computer models of strength capability for different anatomic positions. This approach requires a more manageable set of measurements of subjects, but results in much less reliability for measurements of strength capability for individual tasks. As the predictions extrapolate farther from measured positions, they generally become less reliable.

1.2. Objectives and Scope

The objectives of this project were:

- 1) To develop an experimental design for measurement of strength in children after reviewing and evaluating the available strength measurement literature and accident data.
- 2) To design and construct a portable test fixture and data acquisition system for accurate strength testing that would control anatomic position and immediately provide feed-back on test results to the measurement technician.
- 3) To conduct an intensive study of a small group of children obtaining information, thereby, for further development and refinement of equipment, tests and procedures.
- 4) To measure a larger group of subjects selected to represent the U.S. population of children considering age, sex, and ethnic variations.
- 5) To investigate the utility of a computer based strength predictive model for children.
- 6) To reduce and statistically analyze the data thus collected and present this information in a form which is convenient and reliable for product safety design use.

2. METHODS AND TECHNIQUES

2.1 Design of the Study

The results of strength testing must finally be expressed as a mechanical quantity. There are several possible ways of analyzing the results of strength tests. Strength may be considered as a force acting at a distance, in which case the magnitude of the force and the location and direction in which it was measured must be specified. Alternatively, the linear force generated by the contraction of a muscle group can be thought of as being translated into its rotational equivalent: the torque about a joint center. Therefore, strength measurement and transducer design must include the measurement of a force and a distance or the measurement of a torque.

2.2 Design of Transducers

Since force transducers have been more commonly used, the initial measurement transducers were designed using force and distance measurement principles. In numerous engineering applications, accurate and sensitive force transducers consisting of resistance strain gages with appropriate electrical bridge circuitry and signal amplification are used. A strain gage is a very thin wire arranged in the pattern of a planar grid and attached to a flexible backing. The geometry of the grid is such that pulling the gage in a direction parallel to the plane of the grid causes a very slight change in the electrical resistance of the wire, and this change is proportional to the force. When such a gage is glued securely to a metal surface,

its electrical resistance changes in direct proportion to the mechanical strain (pulling) of the metal. The geometry of the metal support determines the distribution of strain for a given load. That is, the geometry determines the sensitivity of the strain gage to changes in force. Strain gage transducers are linear to within 1% of their full scale range. Their accuracy may be limited by the capabilities of digital resolution and the stability of the signal amplification system. Especially important for this study is the rapid response of strain gages which minimizes errors due to time delay in the transducer.

The electrical output of a strain gage, also conveniently lends itself to computer processing. The voltage output from the bridge circuit representing a torque is sampled and stored as a numerical representation of that voltage on magnetic tape. The major advantage in such a system is that data are captured in a machine readable form, and the manual manipulation of data is eliminated. The accuracy, speed, versatility, and efficiency of such a computerized transducer system were essential for this study.

2.3 Data Acquisition System

The data acquisition system used for this project consisted of a 16 bit Data General Nova 1220 computer with 16K words of core memory, a 24 channel analog to digital converter, a dual Linc tape magnetic tape system, a Tektronics 4010 Graphics Terminal and two digital to analog converters. The D/A converters were used in conjunction with an X-Y plotter to provide a written copy of graphical information from the computer. Twenty-four

instrumentation amplifiers with adjustable gain, were used to amplify the strain gage signals up to a value of ± 5 volts for the 12 bit analog to digital converter. This system preserved a resolution of 1 part in 4096.

2.4 Initial Measurements

The preliminary measurements were made using a system of transducers designed for the right upper extremity. One transducer measured elbow flexion/extension, using a strain ring with the signal being amplified by an instrumentation amplifier. Additional transducers, based upon a cantilevered beam with strain gages, were constructed for the measurement of shoulder adduction/abduction, shoulder medial/lateral rotation. Several versions of each transducer evolved during the early stages of this project. Transducers were used to measure force perpendicular to the limb. In this configuration, the distance from the joint center of rotation to the point of force application was measured in order to express the results in torque units. We experienced difficulty in being able to precisely specify the point at which force was applied to the transducer system and thus introduced some ambiguity into the results of the preliminary torque measurements.

The first prototype strength chair positioned the subject with his elbow flexed at 90° at his side. The right elbow was placed in a cup, mounted on the end of a vertical cantilevered beam. The right hand grasped the end of a second cantilevered beam, or the wrist was strapped to a vertically mounted strain ring, for some of the measurements. Supporting the lower extremity was a third cantilever beam parallel to the tibia and strapped to the ankle. Finally, the

upper portion of the femur and pelvis were strapped to the chair for immobilization.

2.5 Preliminary Experiments

This first prototype strength chair proved invaluable in refining the transducer design and the experimental design. The relationship between anatomic position and measured strength was investigated. The utility and relative advantages of various motivational schemes were evaluated and the effects of movement and dynamic forces were studied. These questions were resolved through the repeated testing of approximately one hundred children, with the first prototype chair.

2.5.1. Inertial Effects

There is reasonable agreement that isometric strength should be measured as a steady state value during a constant exertion by the subject. If motion is allowed during testing, transient inertial forces are generated by the motion. Thus, the relative importance of dynamic effects and speed of transducer response was investigated. Even though an attempt was made to measure static forces and avoid jabs or short thrusts, the compressibility of subcutaneous tissue allowed a certain amount of motion between the center of mass for the limb and the test fixture or strap. Using an accelerometer with appropriate signal conditioning instrumentation, measurement of accelerations and estimation of dynamic forces was done. At a sampling rate of 250 samples per second, it was found that the severe jerk of a strapped forearm could generate up to

100 rad/sec² angular acceleration about the joint center. Such an acceleration could result in no more than 10% additional loading and was found to last no longer than 100 milliseconds. These results, along with considerations of aliasing and wave form distortion were used to establish a sampling rate of 20 points/sec for the strength tests.

2.5.2 Joint Position Interaction

Experiments were conducted to determine if the position of the wrist affected strength values measured for elbow flexion and extension. One would anticipate, on anatomical grounds, that altering the degree of pronation-supination at the wrist would influence the strength capability by changing the position of the muscle insertion. We were concerned with selecting for initial testing a position which minimized the amount of variation from one test to another on a single subject. Preliminary experiments measured elbow flexion and extension with pronated position, neutral position, and supinated position. Since the initial tests showed greater reproducibility for the neutral position, the final strength chair design used measurements with the wrist in a neutral position.

Still another experiment attempted to ascertain the relationship between the strength of elbow flexion, with the elbow joint at a 90° angle, and the position of the shoulder joint. The biceps anatomically spans both the elbow and the shoulder joint and the position of each joint effects the isometric contraction length of the muscle group. In accordance with the well established length-tension relationship of skeletal

muscle, the overall performance of a muscle is effected by its length change. Over the limited range of angles in which preliminary testing and final measurement was done, we failed to demonstrate an effect upon elbow flexion attributable to the shoulder joint position.

2.5.3. Motivation

Motivational techniques were examined in great detail at this stage of the strength study. Several pieces of specialized hardware were constructed and evaluated. A visual feedback unit was devised so the subject could observe the instantaneous results of his exertion. The first unit consisted of a horizontal line across the face of an oscilloscope. This line represented the absolute value of the output voltage from the primary strength transducer channel. As greater force was measured, the position of the line moved upward on the screen proportional to the torque. Children were encouraged to try to cause the line to rise as high as possible. Some children quickly learned that short jabs or pounding upon the transducer would cause the line to move up very quickly. This system seemed to encourage exactly the sort of strength exertion which we did not desire. A second unit was constructed which consisted of a loop of string between pulleys at the floor and ceiling. Attached to the string was a flag and the position of the flag was controlled by a servo-mechanism driving the lower pulley. The result was a display system similar to the "carnival strength tester" which is composed of a mallet,

lever, movable marker, and bell. The electrical signal which controlled the servo position was processed through an operational amplifier connected as a "forgetting integrator" (the feedback element consisting of a capacitor and resistor). The purpose of this integrator was to encourage long, sustained effort: the flag would rise higher as the subject pushed longer and harder. It was also relatively insensitive to short exertions. As attractive as this scheme appeared, however, the flag was often ignored. For most children, especially the younger ones, all their concentration was required to push on the chair in the proper direction with the proper part of their body. The flag appeared to add little incentive. Other forms of positive reinforcement, such as a reward system were tried with M&Ms[®] being awarded in proportion to the degree of effort. Each attempt, however, had its specific drawbacks. The best results, based upon size and shape of the strength-duration curves, seemed to be obtained by simple verbal encouragement. It must be emphasized that the most important aspect of such encouragement consists of empathy between the child and experimenters highly skilled in working with children.

2.6 Strength Criteria and Reproducibility

Finally, two crucial problems had to be resolved before continuing the study: 1) an objective, analytic criterion was needed for determining "strength" and 2) the reproducibility of strength measurements had to be established. The two problems were found to be interrelated. Since the raw data consisted of a sequence of values

for the output of the strain gage transducer, stored sequentially as a function of time containing information about the output of several transducers, relative freedom existed in the methods which could be used to analyze an exertion and extract a representative measure of the child's "strength". As has been previously mentioned, human strength researchers have been in considerable disagreement as to the best measurement of strength. Assessment of strength must occur over a long enough period of time to eliminate effects due to "explosive" strength and yet must be over a short enough duration to eliminate decreases in strength due to fatigue.

It was felt acceptable strength measurement criteria should: a) be indicative of a sustained effort, b) be reasonably reproducible on a test-retest basis, and c) be reasonably representative of everyday observations in child strength, i.e. accurately model the real world.

A variety of algorithms were investigated in an attempt to design a method of unambiguously and accurately estimating "strength" from the transducer output. The concept of an average torque (or force) generated over a period of time was appealing not only from the mechanical viewpoint that both force and time are required to perform a task but also from the physiological and biochemical considerations of muscle energy requirements, the mechanics of contraction, and fatigue. A time-averaging method is both analytically feasible and intuitively satisfying. The duration of the averaged interval and the position of an interval with respect to the onset of exertion was not so easily established. The duration had to be long enough to minimize the effect of a single high point erroneously produced through the process of dynamic inertial effects.

The interval had to be short enough to minimize the effects of fatigue and loss of motivation. Examination of many strength graphs plotted as a function of time revealed instances in which the subject had never really "gotten the hang of it" until the third or fourth second. Other graphs indicated cases in which the child had obviously stopped trying after an initially satisfactory exertion.

To resolve the problem of interval length, a series of experiments involving a hundred subjects was done in which two or more repetitions of a series of tests on the upper extremities were performed. In order to analyze the data, an algorithm for a moving point average was implemented and used to compare the reproducibility of data from one day to another. Intervals consisting of 1 point (50 milliseconds) 5,10,20,40,60 and 100 points were used. For each interval length a moving point average was calculated for all possible intervals in the five seconds in which data were obtained from the subject. That is, an additional interval of the first n points was calculated from the 0th to the n th point, and the results saved. The second interval from the first point to the n th plus 1 point was calculated and saved and the process repeated until the entire five seconds of data had been spanned. The average value for an interval of length n was selected which consisted of the maximum of all possible sets of contiguous intervals of length n . Thus, for analysis of the data, a maximum was selected for interval of length 1 point (50 milliseconds), 5 points, 10 points, 20 points, 40 points, 60 points and 100 points. A variety of statistical analyses were used to attempt to choose an interval length such that the strength differences between test and retest were minimal across all subjects and thus the reproducibility

would be greatest. Intuitively the outcome of the analysis was expected to favor midlength intervals as the variability of long intervals appears to be increased by fatigue and motivational considerations. The results indicated that short and long intervals show larger statistical test-retest variation. Within intermediate length intervals (1,2, and 3 seconds) no one interval was found to be significantly better than the other. Therefore an interval length of one second (20 points) was chosen as the strength measurement since it also seems to give better results with less highly motivated subjects.

In this report, when a single number is assigned to "strength", it is obtained by selecting the maximum one second moving point average after analyzing five seconds of exertion data.

2.7 Portable Strength Chair

This section describes the final version of the strength chair which was used to obtain the population survey data presented in this report. The chair was designed to allow the measurement of 33 isometric strengths of different muscle groups as well as total body weight. The chair was designed to be portable, being mounted on small wheels.

Figure 1 shows the strength chair, graphics terminal and data acquisition system. Notice that the computer, Linctape and A/D converter are built into a console which is mounted on wheels. The work surface of this console folds upward to protect the front of the computer during travel.

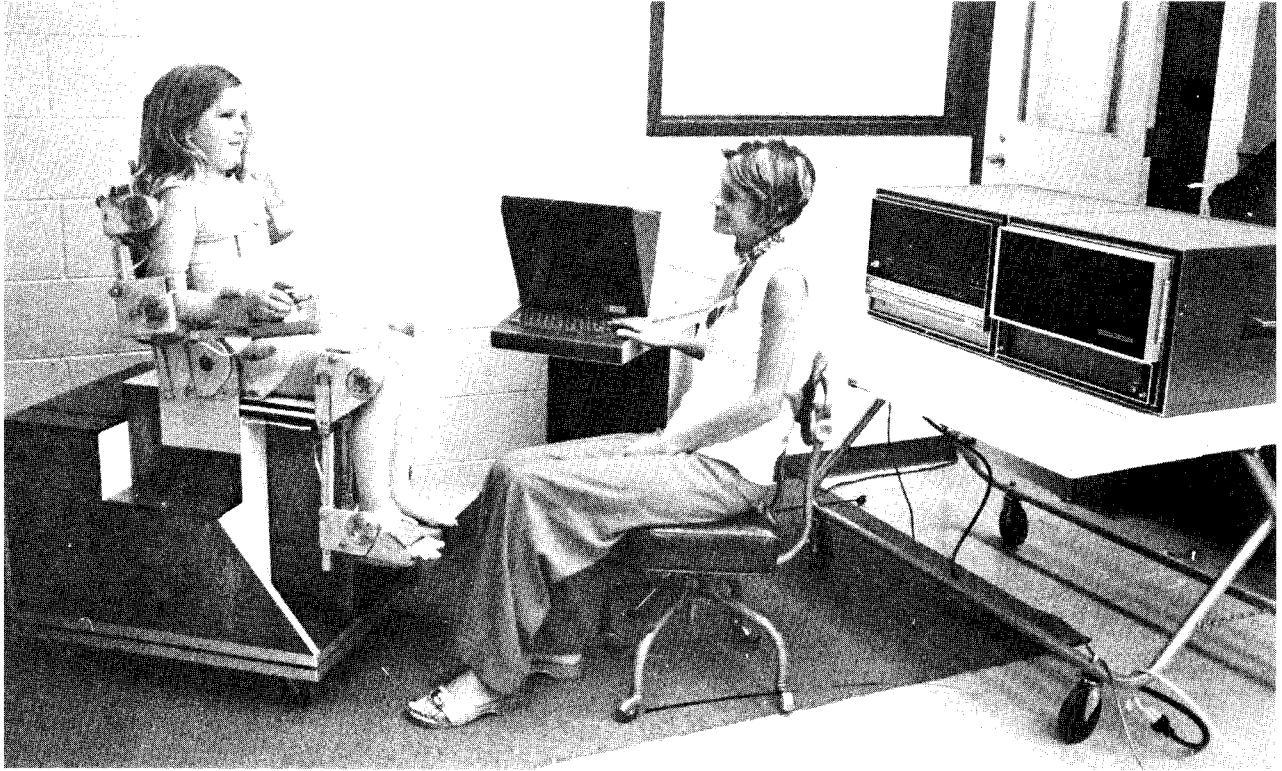

Figure 1 Complete Measurement System

2.7.1 Strength Chair Design

The strength chair consists of a reclining chair with instrumented fixtures which serve as an exoskeleton for the right upper extremity and the right lower extremity. The fixtures are adjustable so that the chair can fit children between the ages of 2 and 10 years. At each major joint, the chair is articulated in at least one plane and can be aligned with the center of rotation for that joint. A transparent window at each articulation aids in this alignment.

Figure 2 and Figure 3 show a side and a front view of the strength chair with the various parts of the chair labeled.

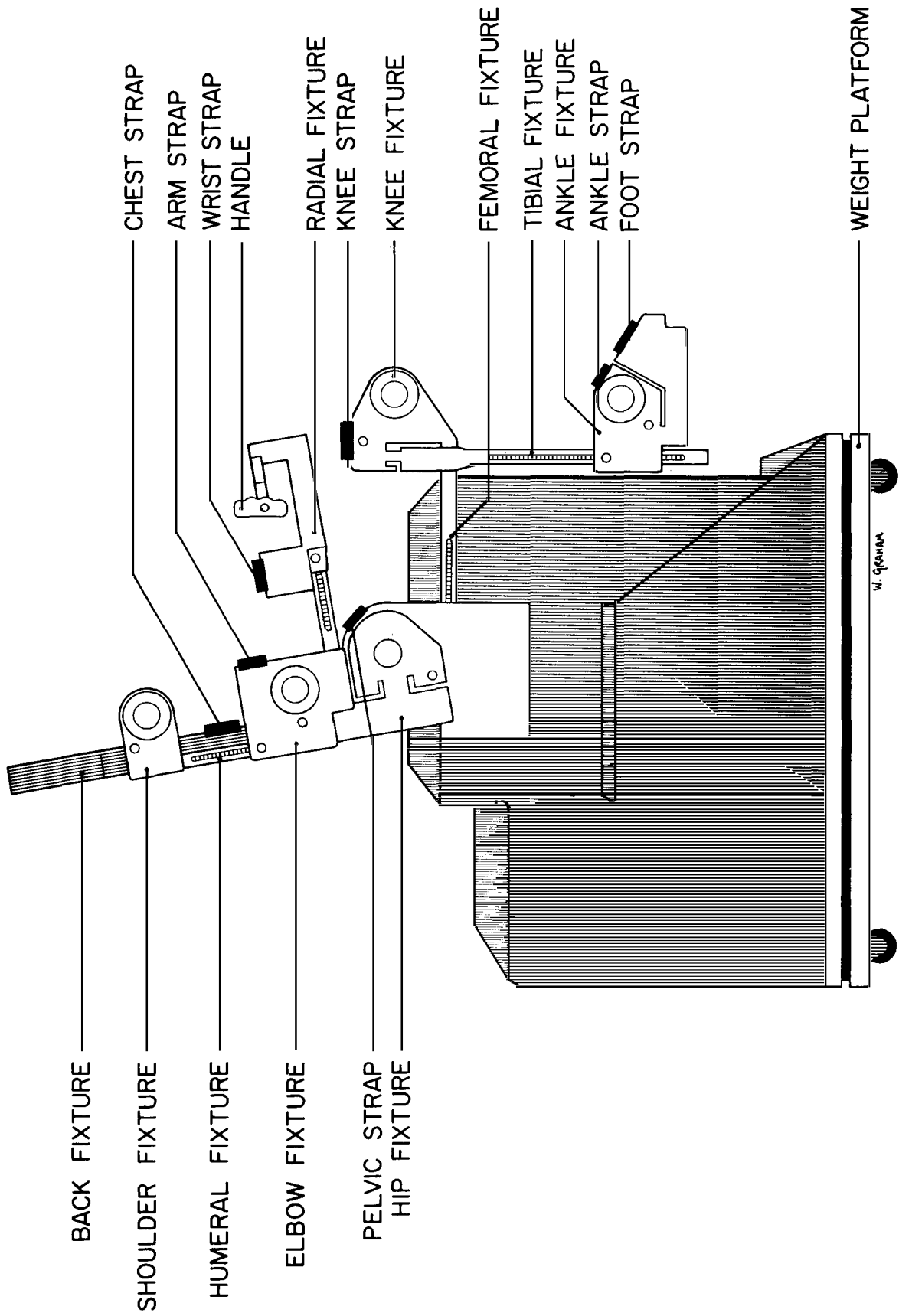

Figure 2 Side View of Chair

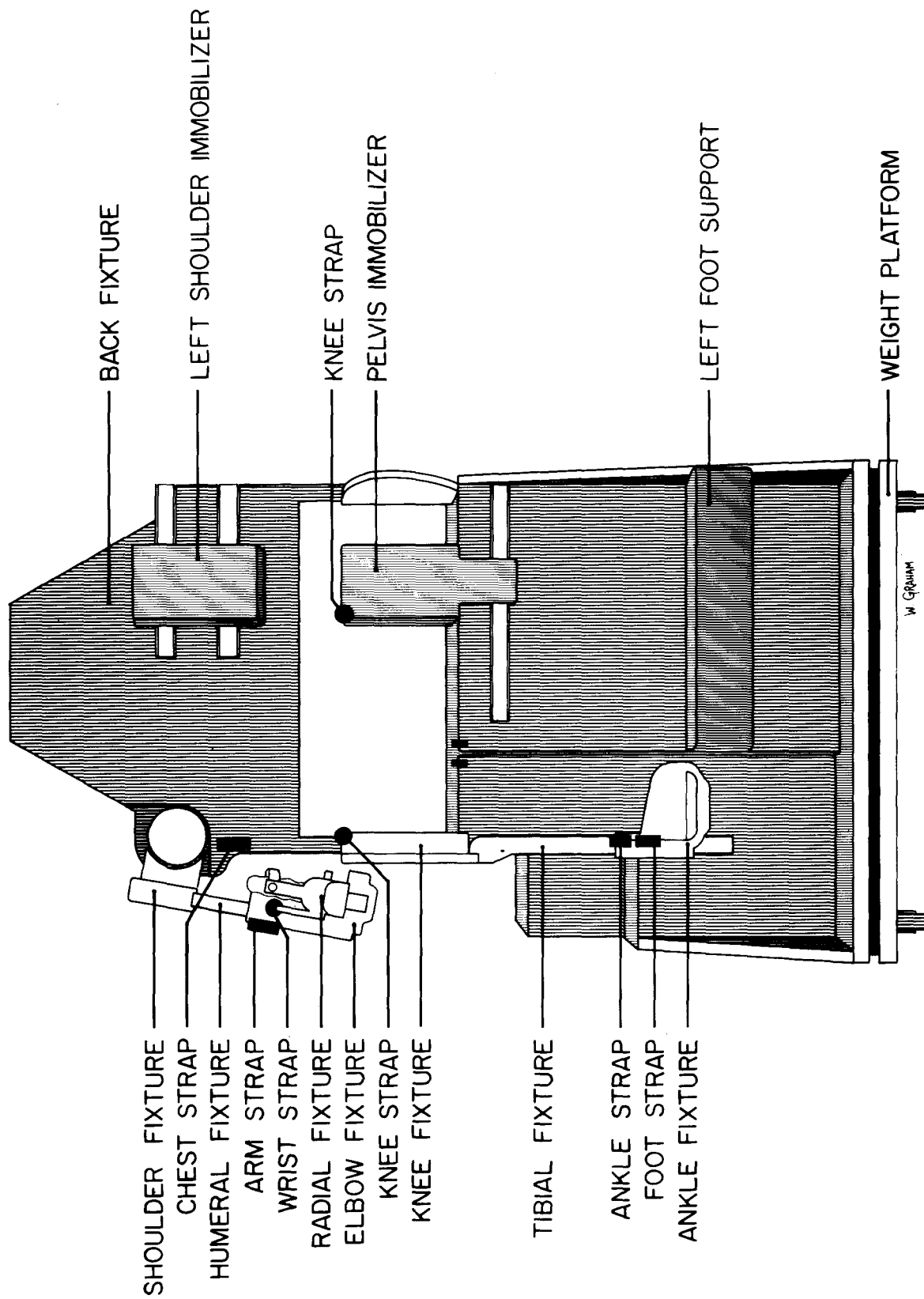

Figure 3 Front View of Chair

Figure 4 and Figure 5 show the chair adjusted to fit a nine year old child in the standard test position. Although there are adjustments for the articulations which allow measurements to be made at many different joint angles, the results described in this report pertain to this standard position. Table I (page) lists the possible joint angles at which strength measurements can be made with the current equipment.

Bright orange rubber padding contacts the subject at all supports. The chair back and seat are also covered with the rubber material which is firm enough to prevent change of the body position without compromising comfort. Two inch wide Velcro[®] provides a strap which can be adjusted for snug fit, can be applied easily, and is strong enough for even 10 year olds, since the material is loaded in a shear mode. The long chest and pelvic straps are attached to seat belt retractors and can be retracted into their supports when not in use.

Strain gages are aligned with each articulation pivot point so that the entire limb fixture distal to the gage location is cantilevered. The gages which were used to measure wrist motions have a slightly different geometric arrangement. These gages are attached to the base of a cantilevered beam which supports a handle mounted on a pivot as shown in Figure 6.

Considerable attention was devoted to the proper placement of strain gages, both to insure the proper mechanical function and to insure that the delicate gages are located in positions inaccessible to curious little probing fingers. This protection is extremely important to insure reliability, since the delicate gages and fine wires are easily damaged.

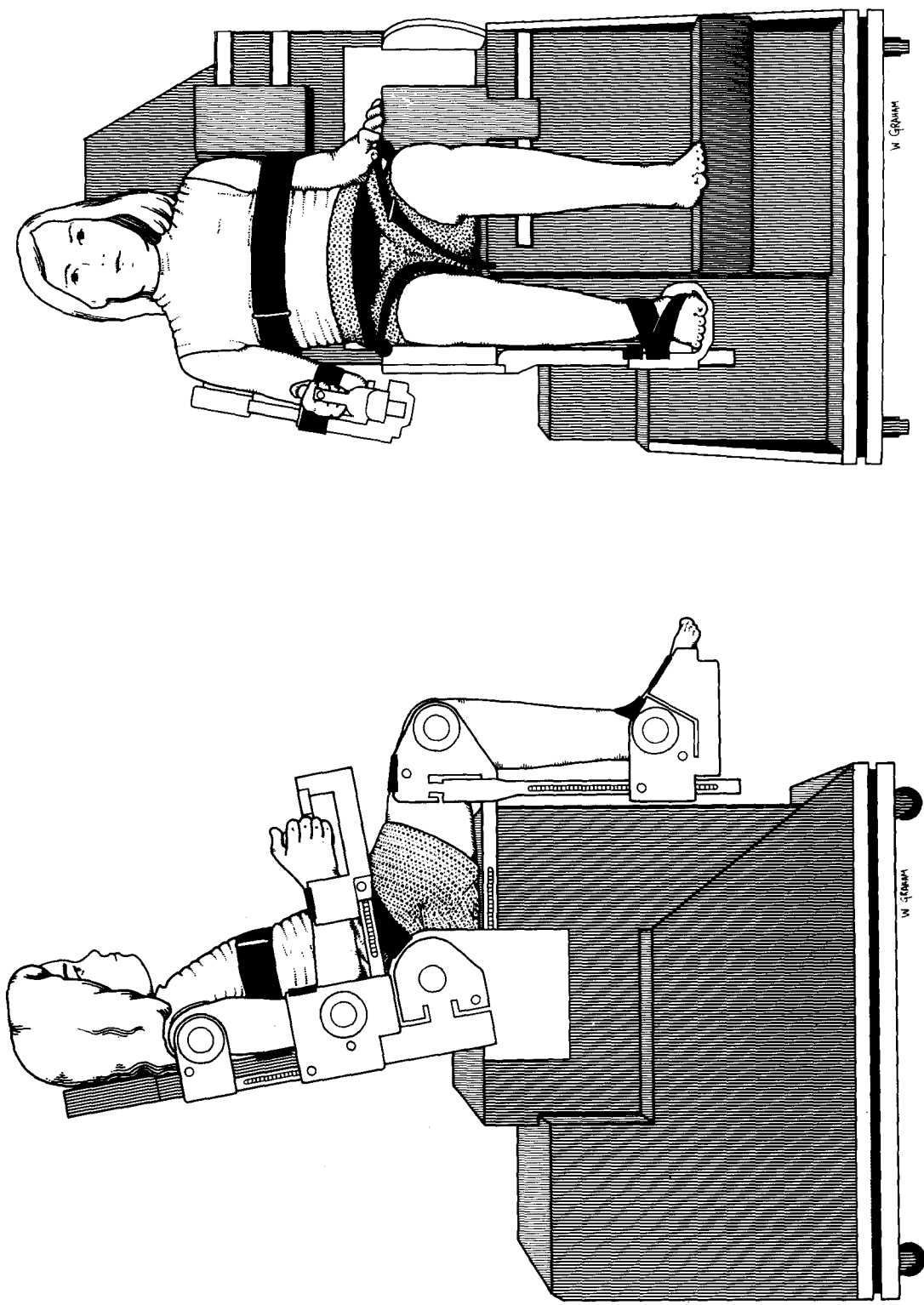

Figure 4 Chair Adjusted For 9 Year Old

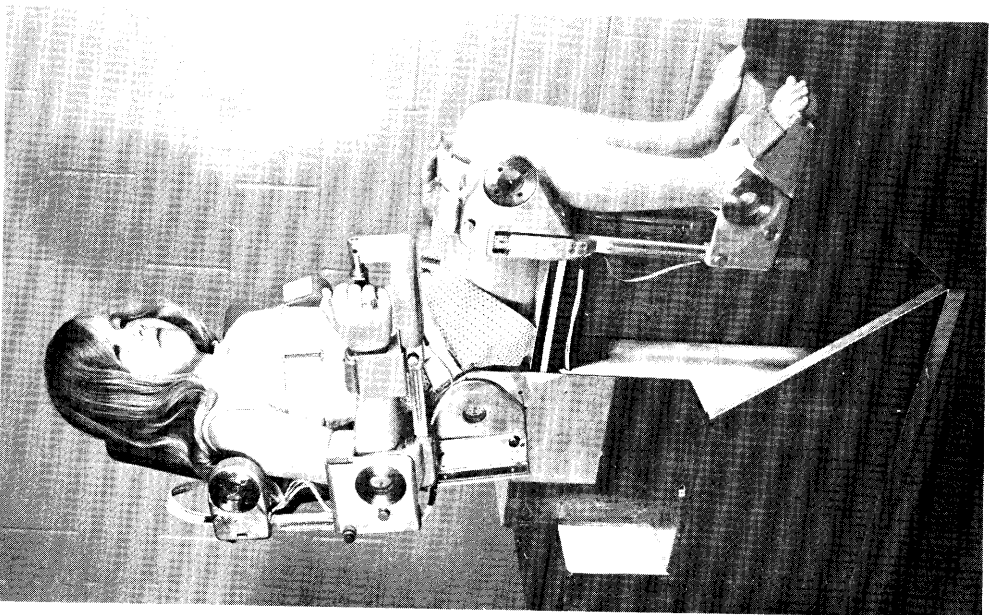
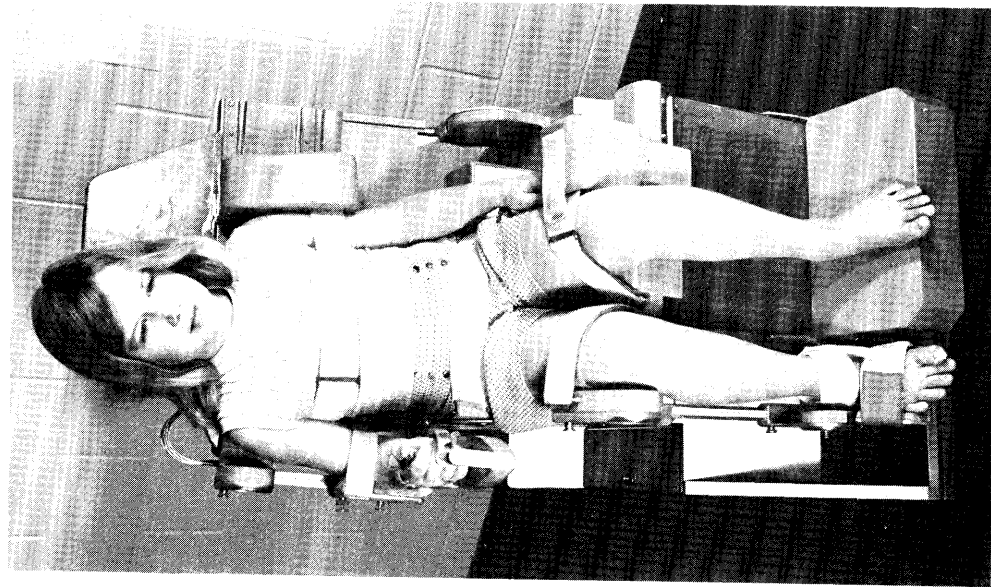

Figure 5 Child in Standard Test Position



Figure 6 Gage Position for Wrist Transducer Used to Measure pronation/Supination, Flexion/Extension, and Adduction/Abduction. (See also Figure 10)

2.7.2. Grip and Pinch Transducer

A separate device is used to make grip and pinch measurements, as shown in Figure 7. It consists of a "U" shaped metal spring with finger and thumb plates mounted at the open end of the "U". Two handles are attached at an angle to the ends of the "U" so that squeezing the handles together tends to close the side of the "U" together. Strain gages have been strategically placed along the inner surface of the spring for force measurement.

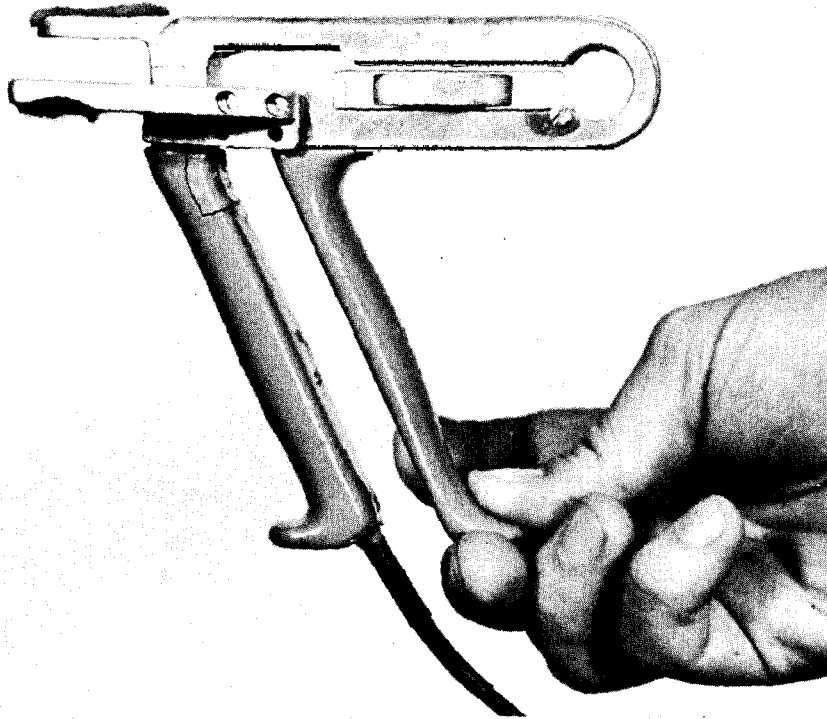

Figure 7 Grip and Pinch Transducer

2.7.3 Amplifiers

Shielded multiconductor cables travel from each gage on the chair and grip transducer to individual instrumentation amplifiers and an associated bridge balancing resistor mounted in the lower rear of the chair. Each of the 24 amplifiers, as shown in Figure 8, has an adjustable gain which may be set between 1 and 1000. Most channels are operated with a gain of approximately 300. After amplification, the signals pass through a multiconductor cable to the analog to digital converter of the computer. Each of the 24 channels is connected

to a separate input of the converter and the measurements are available to the computer under programmed control. A cable from the power supply also receives AC power from the computer console. The chair is supported by four strain rings which are instrumented with strain gages. The strain rings attach to the support platform which has four casters mounted on its underside to allow easy portability of the strength measurement chair.

The chair also contains three large compartments used for the storage of the grip transducer, cables, pads, extra magnetic tapes, and accessories for measurement. The chair weighs approximately 70 kg.

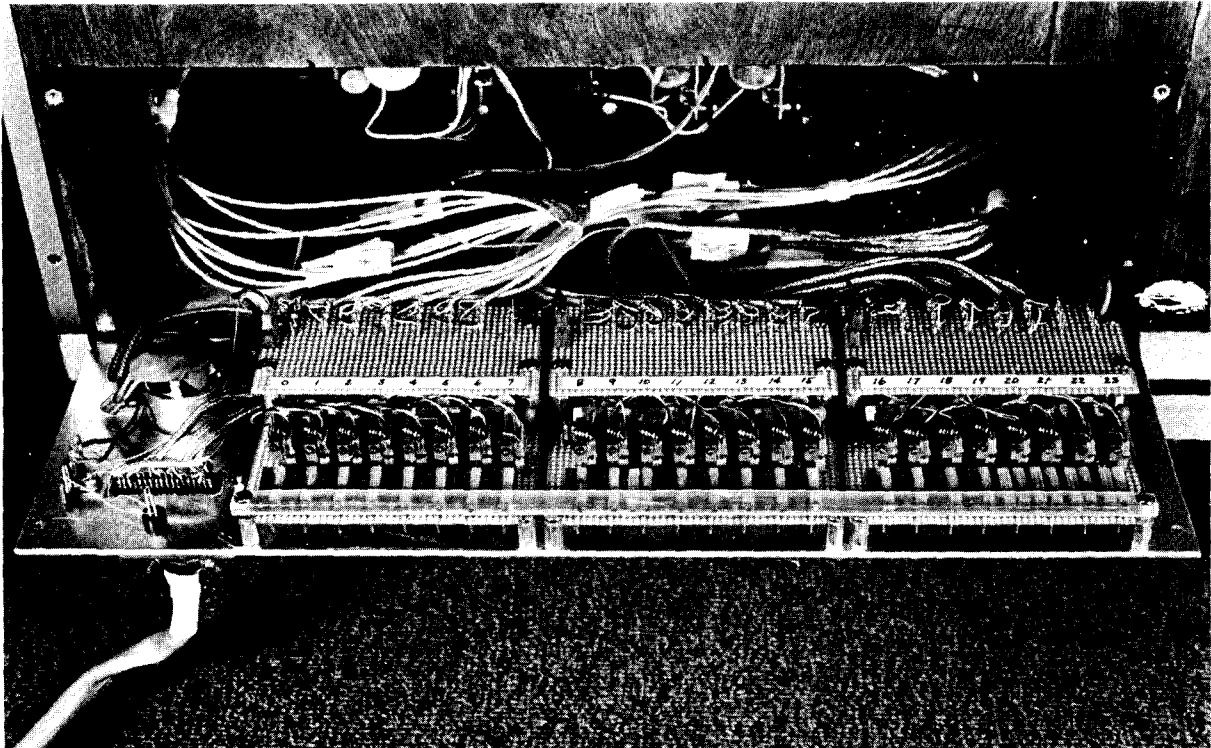

Figure 8 Instrumentation Amplifiers at Rear of Chair

2.7.4 Strength Chair Function

In general, each transducer on the chair is composed of two strain gages which are located on opposite sides of a beam so that one gage undergoes compression while the other experiences tension. For most of the transducers, gage set is aligned with the axis of rotation of a cantilevered beam so that the gages measure torque directly. A detailed derivation of the torque measurement is described in Appendix 4.1. Each set is configured with two resistors and a potentiometer which function as dummy gages and allow balancing of the inputs to the instrumentation amplifiers. The weight of the chair is measured with four strain rings which are instrumented with strain gages and measure the force applied to the ring. The sum of the outputs of the four strain rings supporting the chair measures the weight of the chair and its contents. Thus a subject's weight can be obtained by subtracting the weight of the empty chair from the weight measured with the subject in place. Weight is obtained with an accuracy of 0.1 kg.

The grip transducer, shown in Figure 9, uses two sets of strain gages. For pinch measurements, the gage sets are located a constant distance from the position of the finger plates and force is measured directly. In grip squeeze force measurements, both sets of gages are used as cantilivered beam force transducers. Although each gage set alone is effected by the location and the magnitude of the force applied to the handle, a linear combination of the outputs from both gage sets can be found such that the total force perpendicular to the handle

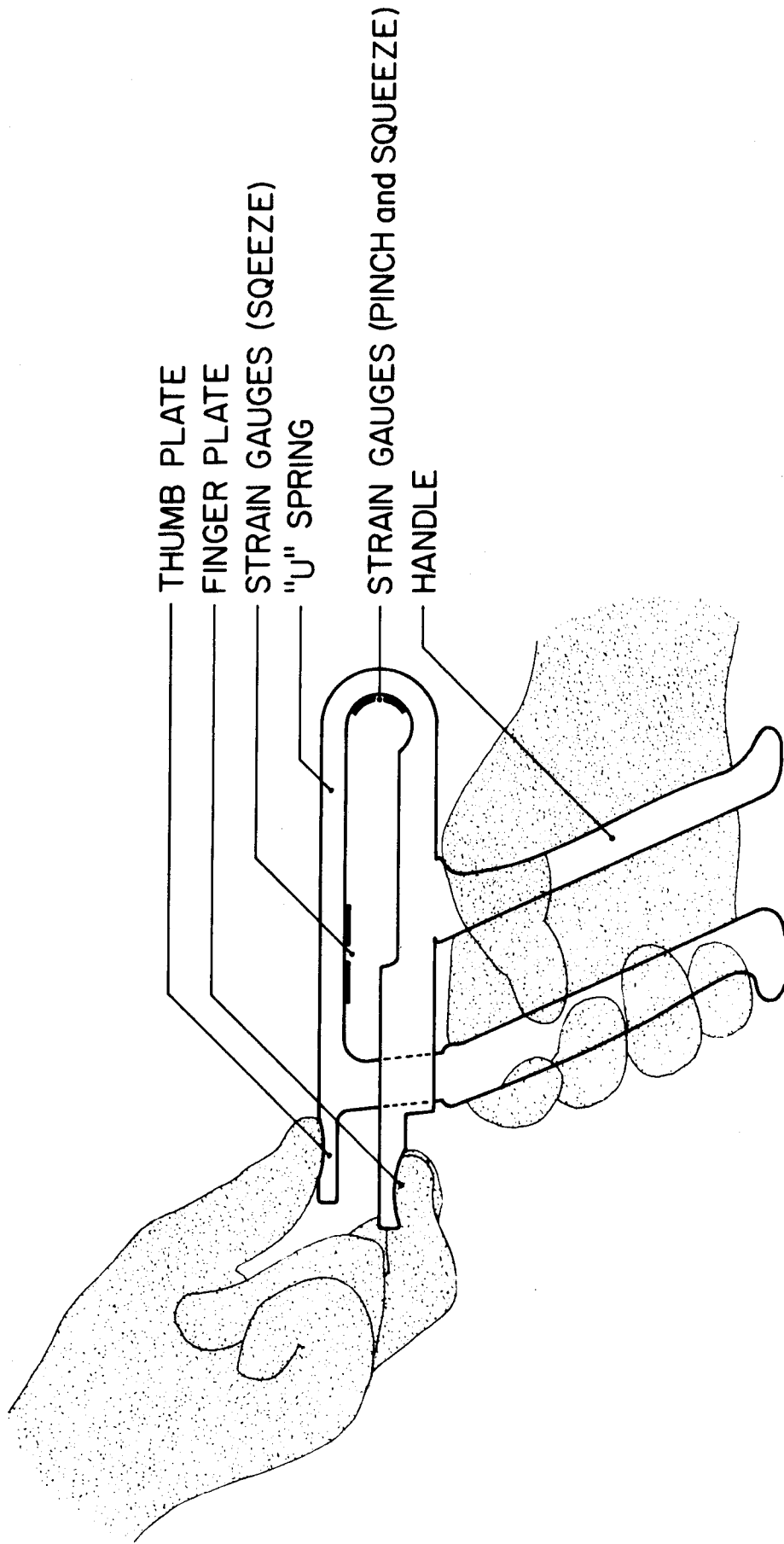

Figure 9 Diagram of Grip Transducer

is measured. Furthermore, this perpendicular force is independent of the exact location at which the hand grips the handle. A second linear combination of the two outputs can be found that measures the squeezing force components parallel to the handle surfaces. Although the data in this report were not reduced by using this second linear combination, the capability to do so exists. Such information could be used to generate the absolute magnitude and direction of the grip squeeze force. Expressing force magnitude as a function of its direction angle may yield interesting information concerning the biomechanical functioning of the grip.

The transducers for wrist flexion/extension, and wrist abduction/adduction operate as sensors attached to the base of a cantilevered beam as shown on Figure 10. The longitudinal axis of the beam aligns colinearly with the longitudinal axis of the forearm. Since force is applied to this beam through a ball pivot, there will be no transmission of torque from the grip to the beam during wrist abduction/adduction. Furthermore, the torque transmitted during wrist flexion/extension is assumed to be relatively small. An additional gage set measures wrist pronation/supination as a torque about the beam's longitudinal axis. For both the wrist flexion/extension and abduction/adduction, the carpal linkage measurements have been used to convert the force reading of the transducers to a torque. All the remaining gage sets used on the chair directly measure torque transmitted through the limb joint. In the measurement of torques, it is not necessary to know the specific point of contact between the limb and the cantilevered limb

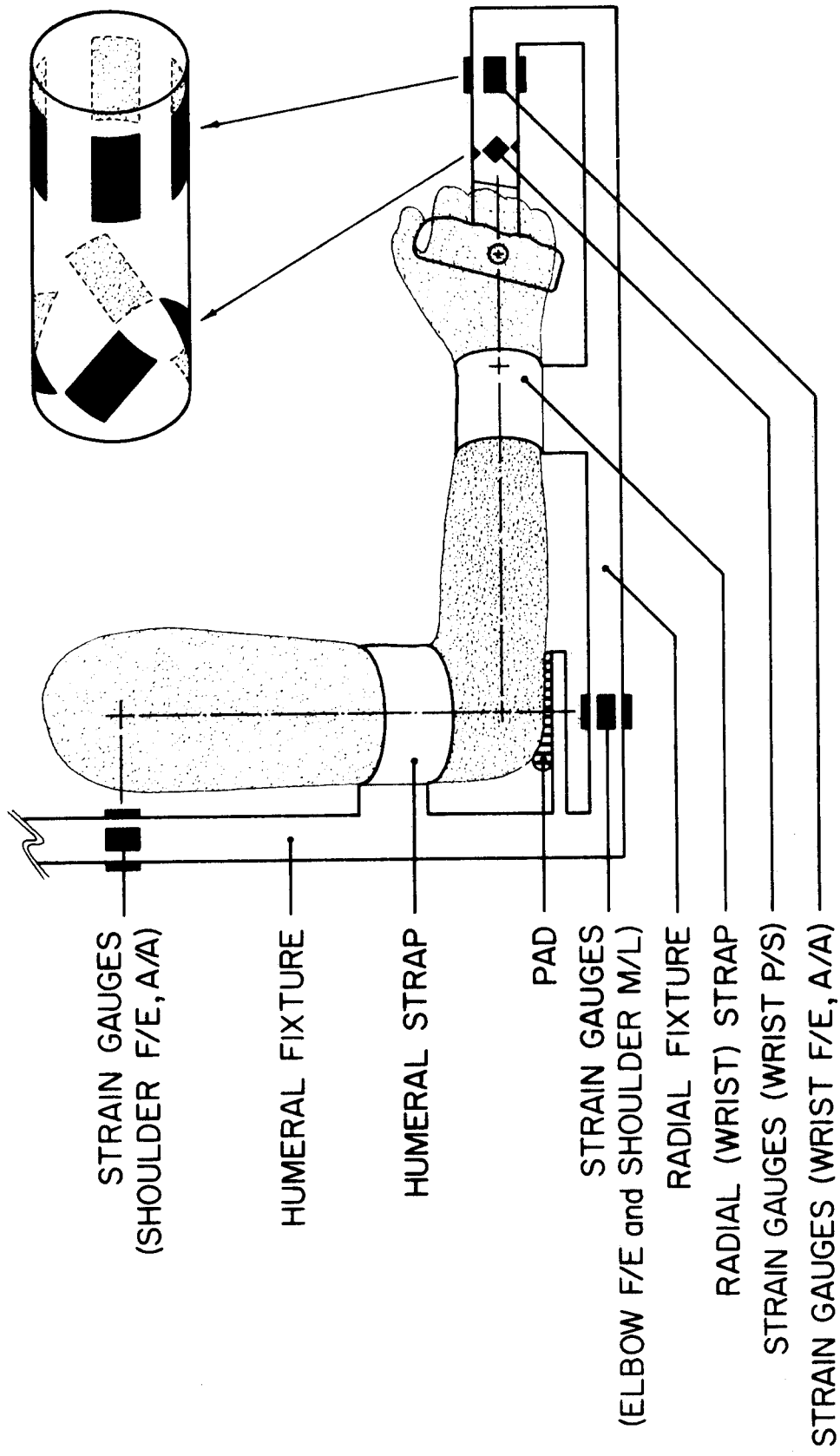

Figure 10 Diagram of Arm Fixture

fixture. The validity of this relationship is demonstrated mathematically in Appendix 4.1. A minor exception to the use of torque measurement is the two sets of gages used for torso flexion/extension. They are aligned with the hip joint rather than the sacroiliac joint and the sacral linkage measurement is used to correct the gage reading to torque about the sacroiliac joint. See Figure 11 and Figure 12.

Heuristically, the function of the gage sets aligned with the joint center can be understood as follows: the activated muscle can be thought of as a taut rubber band spanning the joint and fastened to the limb linkages proximal and distal to the joint. Since the proximal and distal segments of the limb are strapped to the fixtures, the portion of the fixture (or beam) aligned with the joint center experiences the same effective torque loading as the limb joint. The strain gage will respond to the amount of mechanical strain caused by the effect of torque at its location on the beam. Thus the electrical output will be proportional to the torque generated at that joint. Similarly, torque about the next most distal joint can be measured with a second set of strain gages and this measurement is mechanically independent of the more proximal joint. For the circumstance where a more distal joint is "locked" and forces transmitted to the fixture distal to this locked joint, it should be recognized that the entire limb is now cantilevered and the muscle groups spanning the second joint effectively act as a rigid member tending to "fuse" the joint. An example of this could occur if one were measuring elbow flexion and the subject chose to lock his wrist and apply force

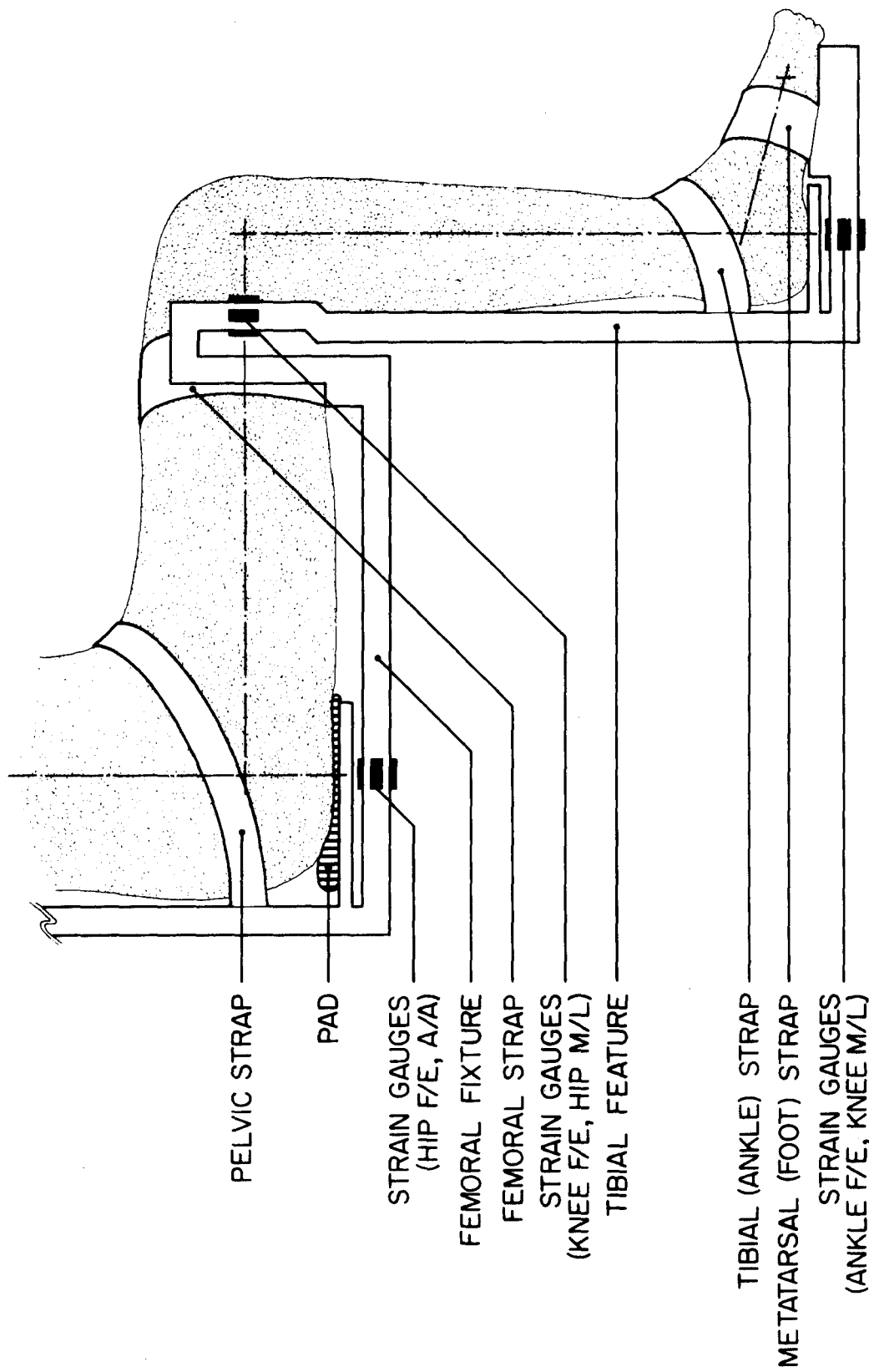

Figure 11 Diagram of Leg Fixture

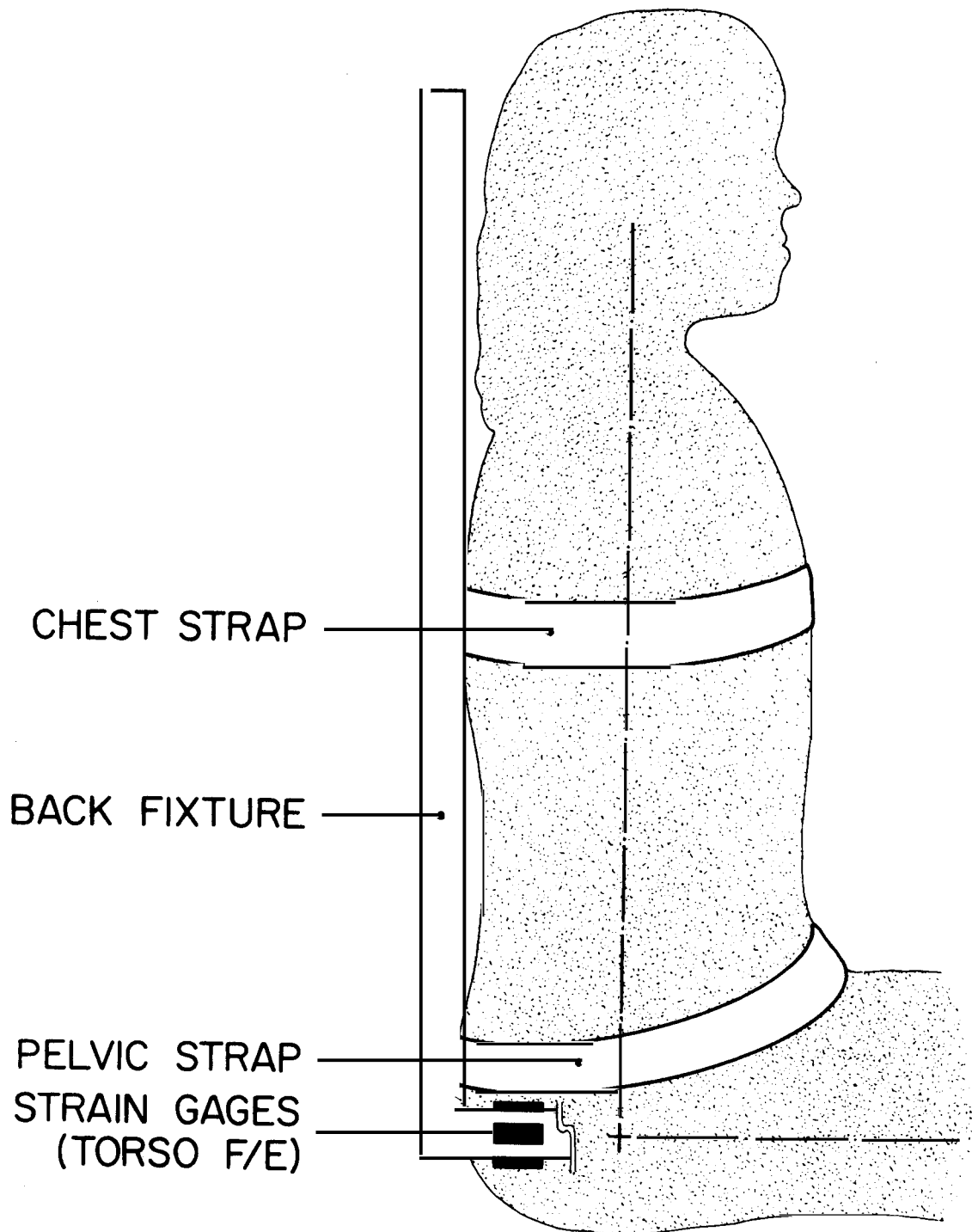

Figure 12 Diagram of Torso Fixture

to the hand grip. This fixation of the wrist only extends the point at which force is applied but since the force still results in a torque about the elbow joint, the correct torque for the elbow will be measured. Thus, the upper arm of the chair consists of a cascaded sequence of cantilevered beams which are attached to the back of the chair which is, in turn, cantilevered from the hip joint rotation center. The lower extremity fixtures consist also of a cascaded sequence of cantilevered beams, referenced to the hip articulation. So long as the chair is properly adjusted to fit the size individual being measured, the torques are reliably obtained and are measured independently of the position of force application.

Initially, the balancing potentiometers associated with each channel are adjusted for a zero output voltage in a standard position. When the chair has been adjusted to fit the subject (all joint angle and linkage adjustments have been made) each channel is sampled again and the value obtained is stored as a zero baseline reading. This zero baseline represents a value which will be subtracted from each measurement to obtain the absolute torque developed about an articulation. Readings are also obtained with the subject sitting relaxed in the chair in the proper test position to obtain the value on each channel with the subject in a resting position. The value of this resting weight which is imposed on each channel is stored along with other test data. The resting weight baseline for elbow flexion/extension, for instance, represents the voltage caused by the weight of the relaxed lower arm on the fixture. Similarly, the zero baseline value represents the weight of the limb fixture distal to the elbow alone.

When a strength test is performed, four channels of information are acquired corresponding to the primary channel as well as the output of three additional transducer channels. For example, when elbow flexion is being measured as the primary channel, the secondary channels include wrist adduction/abduction, shoulder flexion/extension, and hip flexion/extension. Before the test data are stored on magnetic tape, the zero baseline reading for each channel is subtracted from each data point. Since data are acquired from each channel at the rate of 20 points per second, the raw data consist of a resting weight baseline and 100 data points for each of four channels. These data represent the results of a 5 second exertion.

Prior to the performance of each test, the computer program samples each of the data channels to detect the presence of out-of-balance strain gage circuits. Strain gage transducers which are severely out-of-balance produce nonlinearities. Several other malfunctions of the equipment can appear as apparently out-of-balance channels and the overall equipment function is thereby validated. After the chair is adjusted to fit the child, the zero baseline readings for every channel establish an accurate reference value for each transducer output. Changing any linkage adjustment of the chair will change some of the reference values for the empty chair. The program automatically provides for the establishment of this reference value and allows it to be checked easily at any time. The resting weights of the baseline values are required to express the data with compensation for the gravitational effects on the limb. For some tests, the resting weight value is significantly large

compared to the value obtained for the child's exertion alone. The resting weight can be treated as a "no exertion strength test" because of the difficulty in getting a child to completely relax. Great efforts have been made to obtain reliable and accurate estimates of the resting weight and we believe that it provides a reasonable indication of the limb weight contribution to the measured torques.

The data acquisition program automatically samples the input of the primary channel to monitor a significant change in value. The detection of a significant change initiates the sequence of data acquisition for a period of 5 seconds. Thus, transducer output signal insures that data acquisition will occur coincident with the initiation of significant effort. This insures that the data measured is not contaminated by fatigue effects of previously unmeasured exertion before the data acquisition commenced.

Four channels of data are sampled simultaneously for several reasons. Minor correction factors used in reducing the chair data require a knowledge of other muscle groups which are simultaneously causing motion in the same plane. Many of the secondary channels are recorded for this purpose. A second reason is that a subject occasionally becomes confused and valiantly performs the wrong test. The presence of data from the other channels allowed recognition of this situation and exclusion of the data. Finally, there are counter forces since, as a subject tries to flex his elbow, he tends to perform an extension of the hip. For this reason, one of the secondary channels measured when elbow flexion is obtained

includes hip flexion/extension. Time limitations have not permitted a thorough analysis of all secondary strength effects. Nevertheless, the advantages of such simultaneous recording appear obvious.

2.7.5 Calibration

A computer program controls the automatic calibration of all strain gages on the chair. For calibration, the chair is placed in a standard position and three weights are attached to the chair. One weight is attached to the end of the upper extremity fixture, a second weight is attached to the end of the lower extremity fixture, and the third weight is attached to the rear of the chair back. The chair with three weights attached is shown in Figures 13 and 14. The standard calibration position is chosen to generate a significant input on each of the arm, leg, and torso channels. The calibration program then calculates torque vectors for each channel and computes a calibration factor which is stored in a special file on magnetic tape. Each time the data acquisition program is run, it copies the data from the calibration file and uses these values to compute torques for each of the channels. The entire calibration of the chair can be accomplished in several minutes with little bother.

Accurate data, in part, depends upon the proper alignment of the subject's joint centers with those of the chair articulations. The chair is adjusted at the proximal link of the limb linkage, as determined from the linkage measurements,

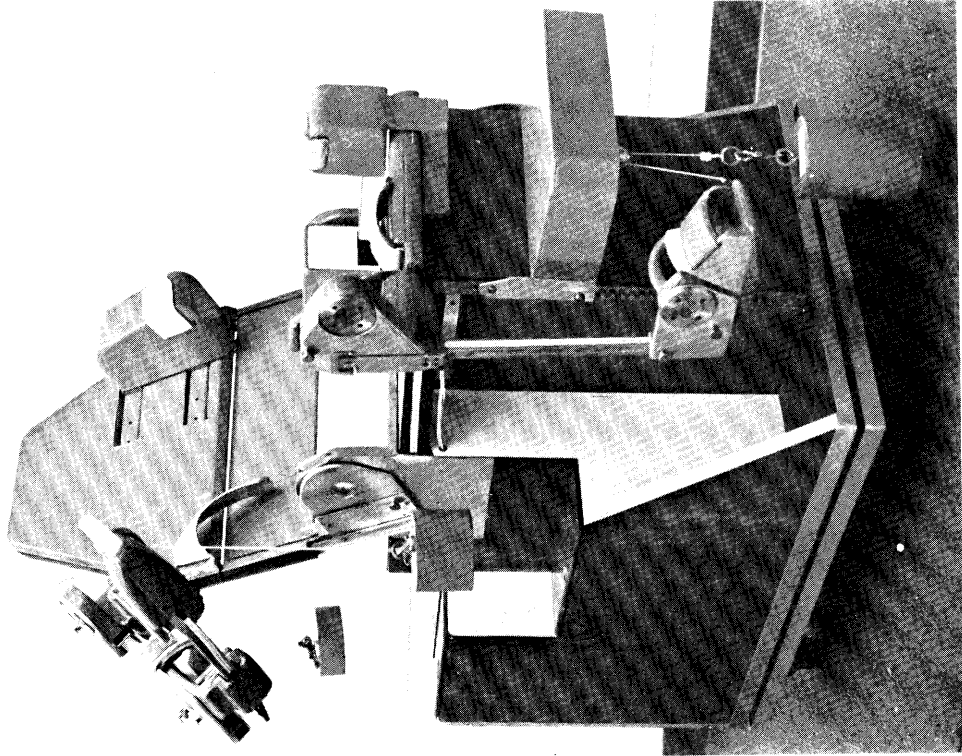
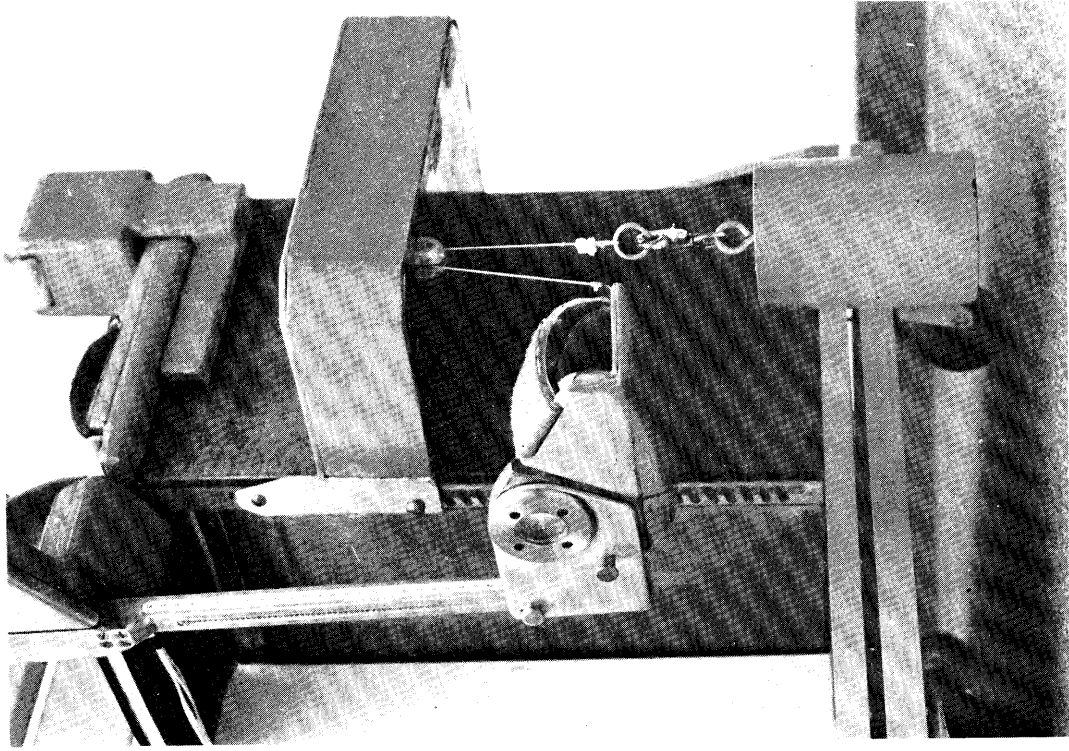

Figure 13 Chair in Calibration Position

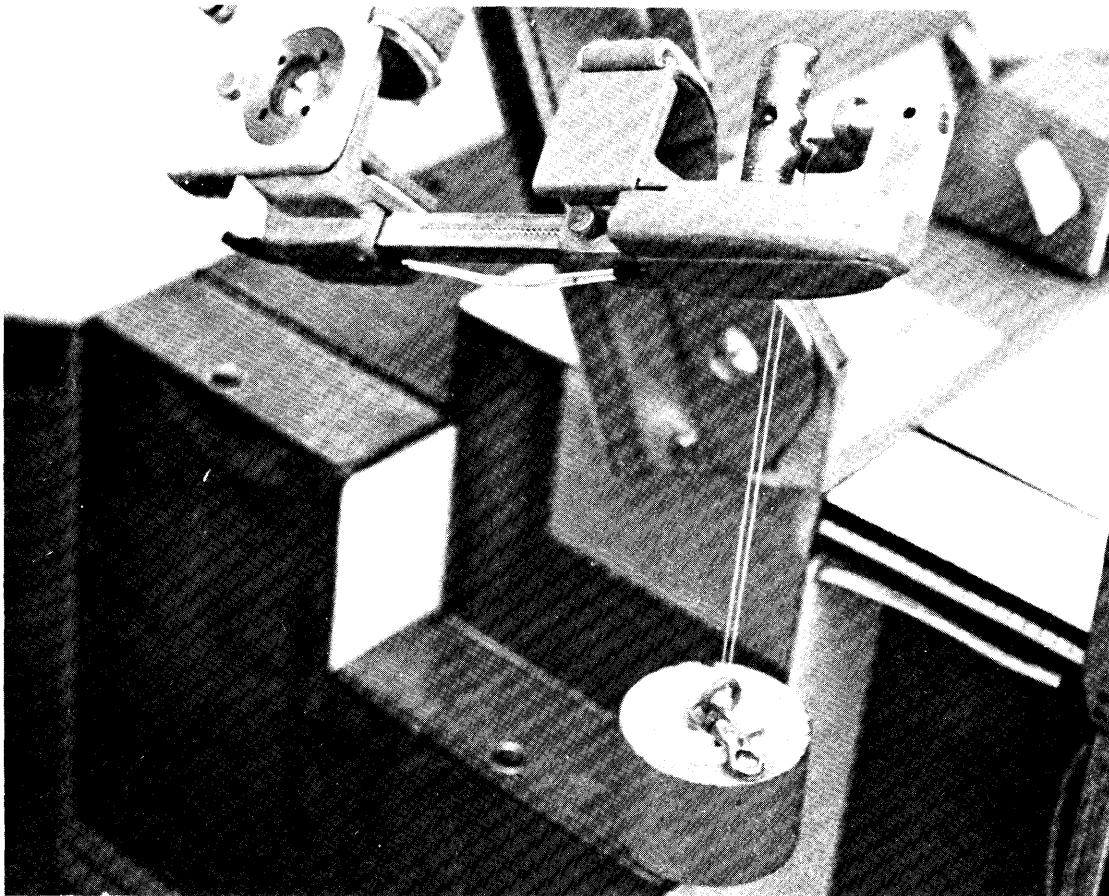
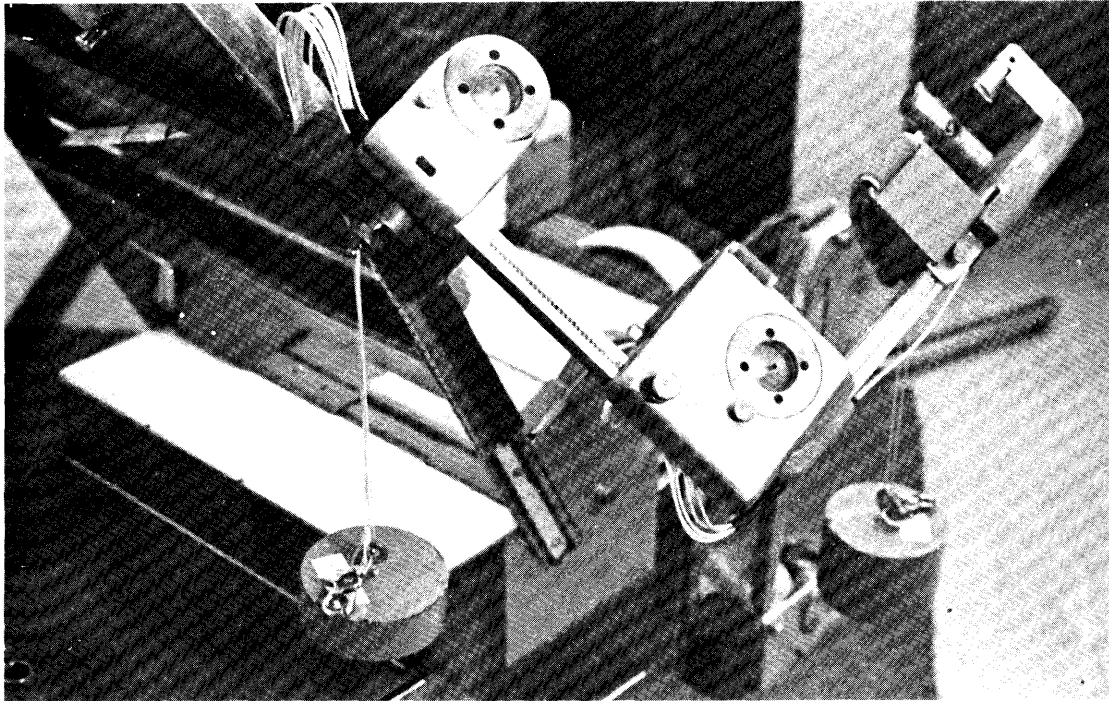

Figure 14 Attachment of Calibration Weights

and the child is strapped into the chair. Relative motion between the limb and the limb fixture may be detected as the chair articulation is moved through a small angle and appropriate adjustments can be made. Thin rubber pads with Velcro® fasteners can be used to adjust the joint center with respect to the chair. The linkage adjustment in one direction and the shim pad in the perpendicular direction are thus used to maintain joint center alignment.

2.7.6 Summary

The strength chair allows measurement of thirty-three isometric strength tests of different muscle groups as well as measurement of total body weight. Measurements can be made for different arm and leg joint positions. They are accomplished in a highly automated fashion reducing recording error and testing time. Furthermore, the chair comprises a complete transducer unit which is easily transported to school measurement sites.

2.8 Data Acquisition and Display

Extensive enhancements to the Basic® language were written to accommodate real time devices. These include the control of analog to digital conversion by means of a real time clock, the use of a second real time clock for timing of intervals, and the control of digital to analog conversion and the graphics terminal. These assembly language enhancements were optimized for the equipment available and allowed almost all of the data acquisition analysis programs to be written in the Basic language.

Computer programs were written to acquire and store the strength data in an efficient and consistent manner. A subject's testing session was prompted through an interactive dialog with the tester. An initial section of the program analyzed the strength chair performance for proper hook-up and functioning. A data file was created on magnetic tape to receive all information gathered during the session. This included the subject's name, age, birth-date, sex, handedness, testing date and previous filename information followed by all linkage measurements and the current calibration factors for the strength chair transducer. Next, the body weight was computed from transducers within the chair.

The voltage output of each transducer was sampled both with the child out of the chair (zero baseline) and with the child sitting relaxed in the chair (resting weight baseline). Each reading was the average of 20 samples from each transducer over a one second period.

After each strength test, the tester had the option of re-sampling the zero baseline or resting weight baseline if the chair's fixture positions had to be changed for any reason.

Finally, a sequence of strength tests was loaded into the program and actual testing begun. The name of each test was automatically displayed on the graphics terminal and instructions were explained to the subject. The computer waited for a significant transducer output in the direction specified by the test. A short audible tone was heard when the sampling began (the subject pushing in the proper direction with the proper limb) and data was acquired from a primary and three secondary transducer channels for 5 seconds.

At the end of the test, a second audible tone was heard signalling the end of the test. Immediately thereafter, the computer displayed the data obtained from the primary transducer as a graph of torque or force versus time, as shown in Figure 15. The tester

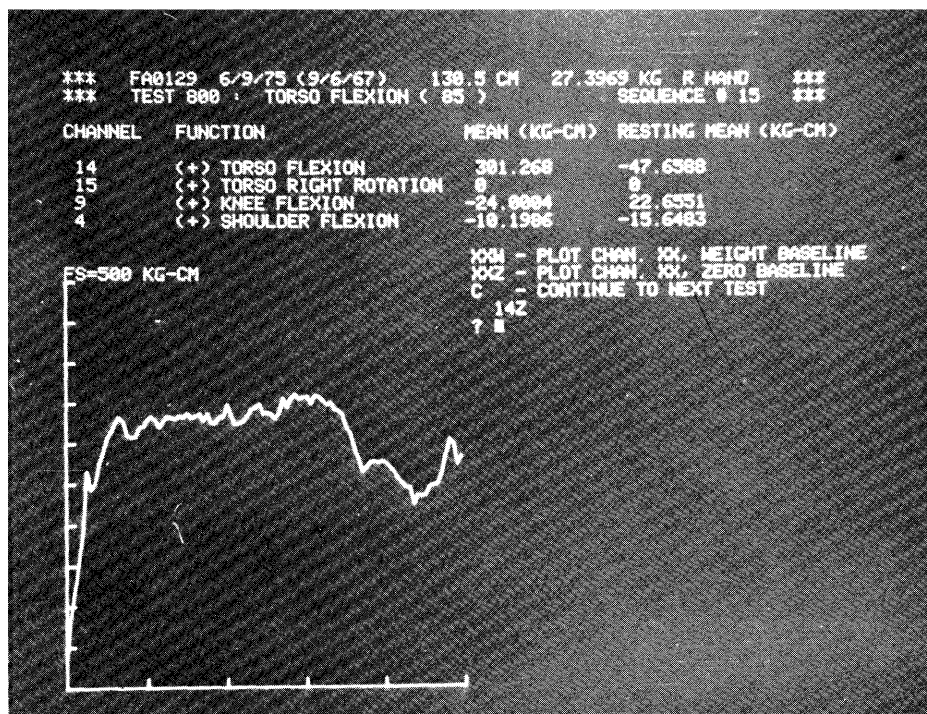

Figure 15 Graphics Display: Primary Channel Plotting

could then evaluate the results and discuss them with the subject ('this mountain shows you were pushing very hard...'etc). If, in the tester's opinion, the child understood the instructions and exerted a sustained effort for at least 2 to 3 second, the results were stored and the test sequence continued. If the results were unacceptable, there were three options: the results could be deleted and the test repeated, the results could be retained

and the test repeated or the results could be deleted and the test deferred until later in the sequence. The tester also had the option of displaying a graphical form of the three secondary channels of data. An example of a graphical terminal display with all four channels of data displayed is shown in Figure 16.

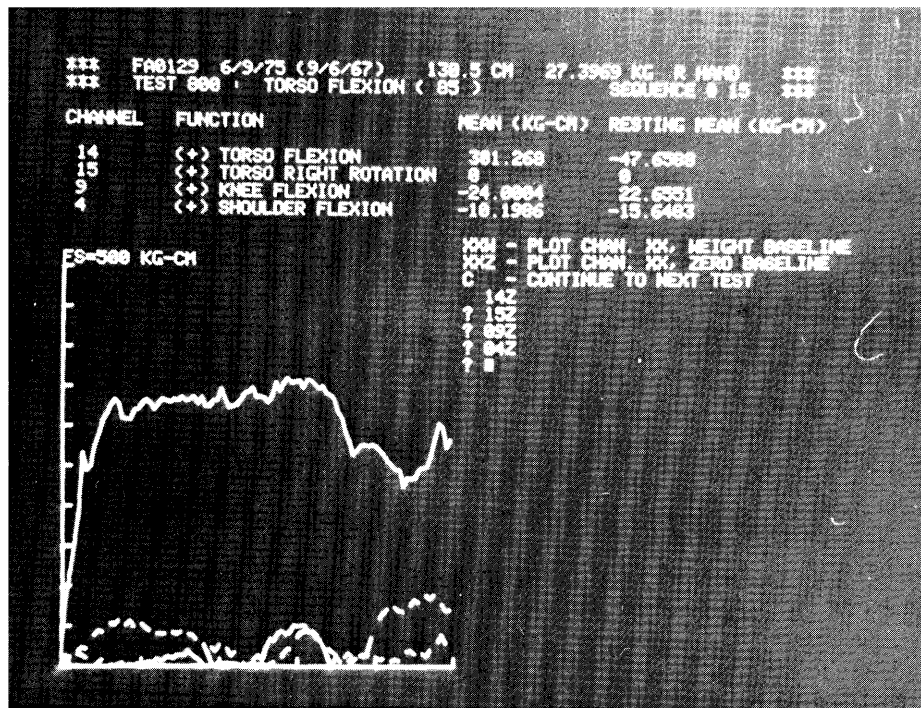

Figure 16 Graphics Display: All Channels Plotting

Thus, the results from one strength test consist of a test code, a joint angle position, an array of 400 data points (100 data points/transducer for four transducers) and four resting weights. Both the data points and the resting weight baselines were expressed with respect to the zero baseline values. Following the end of the test sequence, the data file, containing all the aforementioned data, was closed.

Once the strength tests are stored on magnetic tape, data readout programs could be run to regenerate: 1) a table of all background information, including linkage measurements and calibration factors on a particular subject's test session, 2) torque or force versus time graphs on the graphics terminal of all test results and 3) permanent records of the same graphs plotted by an X-Y plotter. Examples of these plots are shown in Appendix 4.2. Such programs were used extensively during the initial phases of the study to evaluate instrumentation, test session procedures and to analyze the data.

2.9 Population Survey

The children who participated in this study were recruited from a variety of sources. An initial group of 100 children ranging in age from 3 to 10 years were recruited for measurements in the Child Strength Lab of the C. S. Mott Children's Hospital. This group of children returned repeatedly to the lab for measurements as new features of the instrumentation were developed. They provided the initial data which allowed an experimental design for the population survey.

An additional group of subjects was used for the population survey which produced the data for this report. These subjects came from two sources. Previous participants in the Child Measurement Study (Physical Characteristics of Children as Related to Death and Injury for Consumer Product Design and Use: NTIS#PB-242-221) were actively recruited to obtain measurements within the laboratory. The second group of subjects was recruited in local nursery schools and elementary schools for a more restricted set of measurements.

In each case, consent forms, information sheets and questionnaires were sent home with students prior to testing. Examples of the information sheet, questionnaire and consent form can be seen in Figure 17, Figure 18 and Figure 19.

For the population survey, the testing team consisted of three research assistants, each able to do the necessary recruiting, measuring, testing, and recording. Each member of the team was a certified teacher and had extensive experience working with parents and children. While one member of the team obtained the linkage measurements and tested the subjects, another operated the computer console. The third member of the team kept a continuous record of the number of children tested, age, sex, racial and socioeconomic variables as well as serving as recruiter and scheduler.

At elementary and nursery schools, the testing hours were effected by school hours, lunch, naps, and parental schedules. At each location outside the laboratory, an environment had to be found which would accomodate the equipment and facilitate easy loading and unloading. When working with very young children, an attempt was made to keep the atmosphere as familiar as possible, often by having a friend watch while a child was tested. This was not only reassuring but also conveyed information about the tests. In the elementary school, children were taken from class for 15 minutes for testing. School staff, teachers and administrators were very helpful in generating enthusiasm and interest for the project, as was word-of-mouth advertising from one student to another. Once testing began, the excitement of those subjects who had been tested was an important feature in perpetuating the

THE UNIVERSITY OF MICHIGAN
ANN ARBOR

Dear Parent:

The Department of Pediatrics and the Highway Safety Research Institute of the University of Michigan are jointly conducting a study of the strength of children between the ages of two and ten years. We have made arrangements to measure children at your child's school.

The research is being sponsored by the Consumer Product Safety Commission. Through this study we hope to determine the average strength of children of a given age and the range of strength. This information is important for the safe design of furniture, toys, and other products to be used by and for children. For example: how much force should be required to operate the hand brake on a bicycle to be used by a six year old? how much force might a running two year old exert against a glass door?

Data on average strength are also needed by doctors in evaluating the progress of children with diseases which affect their physical strength. This information is not now available to physicians or people concerned with manufacturing safe products for children.

The measurements will be done by an experienced team, with equipment especially constructed to be safe for children and enjoyable for them to use. A special chair has been designed to provide support for the child as he/she pushes or pulls a lever or strap with one arm, one foot, etc.. Since there is no total body movement, this is a safe method of measuring strength, and has the approval of the University of Michigan Medical School Human Use Committee.

We have included a brief questionnaire with this letter. Because our sample will reflect the total U.S. population of children, we need to ask questions about race, education, and occupation. Such information will allow us to insure that each ethnic and minority group is adequately represented in our group of children.

It is necessary that children being tested present a signed consent form. They will be asked to remove their shoes - no other disrobing is necessary. The testing will require them to be out of their classrooms for about 15 minutes.

I will welcome any questions you may have. Telephone 763-4097.

Sincerely yours,

Clyde L. Owings

Clyde L. Owings, MD, PhD
Assoc. Prof. Pediatrics &
Electrical Engineering
F2705 B Mott Hospital
Ann Arbor, Michigan 48104

Figure 17 Information Sheet

CHILD STRENGTH STUDY
University of Michigan Department of Pediatrics
Ann Arbor, Michigan 48104

Name of School _____ Name of Teacher _____

Child's Name _____

Address _____

Child's Date of Birth _____ Male

Female

Child's Race _____

Mother's Occupation _____

Father's Occupation _____

How long have you lived in this community? _____

Mother's Race: Black Oriental White

Other Please specify _____

Father's Race: Black Oriental White

Other Please specify _____

Mother's Education: 8 yrs. or under 9-12 yrs. More than 12 yrs.

Completed More than 16 yrs.

college (16 yrs)

Father's Education: 8 yrs. or under 9-12 yrs. More than 12 yrs.

Completed More than 16 yrs.

College (16 yrs)

Number of brothers _____ Number of sisters _____

What is the birth order of this child in relation to brothers and sisters? _____

For example: 1 - oldest, 2 - second oldest, etc.

Has child been under treatment for any serious illness? _____

Figure 18 Questionnaire

CHILD STRENGTH STUDY

Consent Form

I, the undersigned, understand that the purpose of this study is to take some strength measurements of my child. I am aware that these measurements will enable collection of information about the physical strength of children at different age levels and use of this information in constructing guidelines for the safer design of children's products.

I have been informed that there will be no health hazards or discomfort to my child associated with this, and that participation is voluntary. In order to take measurements with accuracy, it is necessary for the child to remove shoes only.

I further understand that all of the data is confidential and I agree to allow publication of any or all of the data collected on my child if presented in a coded form.

Child's Name

Signature of Parent

Date

Figure 19 Consent Form

positive atmosphere within the school, For subjects measured in the laboratory, parents accompanied their children, often with other siblings. Children were able to watch another subject perform a few tests, and if desired, go to a small play area until it was their turn. This kept distractions to a minimum and yet provided an atmosphere of security. Parents were always able to remain with their children. In almost all cases, the parents were extremely cooperative and very interested in the strength study. The children found participation to be very enjoyable and often had parents of their friends call our laboratory to see if their children could be tested.

2.9.1 Testing Procedure

Testing done at the Child Strength Laboratory of the C. S. Mott Children's Hospital was completed during one or more visits by each subject. The older children (6 to 9 year age group) were usually able to complete all thirty-three tests in the protocol in a single visit, with rest periods during the testing procedure. Younger children (3 to 5 year age group) usually required at least two visits. Again, frequent rest periods were allowed and usually at least two children were in the laboratory at one time so that one was being measured while the other rested.

In the elementary and nursery schools, the number of tests and the order of testing differed slightly from those in the laboratory. It was possible to obtain permission to measure children for a strictly limited period of time: 15 - 20 minutes. The measurement tests chosen were those designed to

obtain the maximum amount of information within this allotted time. Because of the time restriction a smaller number of tests for each child was obtained by field measurement. This usually consisted of 9 to 11 tests for the younger children, with 15 to 18 tests being obtained for the older children.

In all schools visited, the children were tested in a private unused room. A child was brought from his or her classroom to become acquainted with the testers. The child usually had the opportunity to observe another child performing strength tests with the equipment. During this time, one of the testers processed the child's questionnaire and entered the pertinent information in the computer, that is: age, birthdate, sex, handedness, etc. The reverse side of the child's questionnaire form contained a parental permission sheet and no child was measured without parental permission. The testing procedure was described to the child in a clear and simplified form and he was instructed to remove his shoes for height measurement. The linkage measurements were obtained with the child sitting on the rear portion of the measurement chair. At this time, the body weight was obtained by recording the voltages produced by load cells which support the chair.

The size of the chair was adjusted to correspond to the linkage measurements obtained for the particular child. These measurements were also entered into the computer from the keyboard and the chair was adjusted to a "standard test position" as described in the test description section.

Before the child was placed in the chair, the computer measured the initial voltage produced by the weight of the empty chair on each of the strain gages. The chair having thus been adjusted to fit the child, he was seated in the chair and given time to feel comfortable. During this process, the tester explained the use of the restraining straps and the child was strapped in position. The children were often able to strap some of the Velcro® straps for themselves and this served to decrease any apprehension about the strapping process. In this way the children recognized the easy removal of the straps and their own control over their confinement. With the child in a resting, relaxed position, the value of the voltage on each of the strain gages produced by this relaxed position was recorded by the computer. Then the sequence of testing was begun. It was explained to the child that he should sustain each movement as hard as he could, until the terminal sounded an audible tone, generated by the computer program 5 seconds after the start of data recording. At the end of each test, a graph of torque or force versus time was displayed on the computer terminal. The tester could then evaluate the child's performance and decide to accept or repeat the test. The decision was made to repeat or to delete a test if the graph indicated a significant amount of time in which there was little exertion by the child or if the direction of the test was wrong (for example, if the child performed an elbow extension rather than a requested shoulder abduction). The amount and type of explanation of

each test differed depending upon the age, personality and mood of the child being tested. A varying amount of visual demonstrations, in addition to verbal descriptions, were used by the testers to clearly and explicitly transmit test instructions to many subjects. The tester frequently used her finger to give direction to the child's exertion and make more explicit the desired test. For example, in testing knee extension, the tester would hold her finger in front of the child's foot and ask that the child try to make his toes touch her finger. An older child doing the same test might need only to be told to push his foot out as if he were kicking a ball. In testing shoulder abduction, a pad was placed next to the right side of the child's elbow between his elbow and the elbow fixture of the chair. He was then instructed to "squeeze" the pad with his elbow. Specific examples of comparable activity were used whenever possible in order to make test instructions clear to the child. With younger children, it was sometimes necessary to unstrap the limb being used and physically guide the child through the desired motion. For example, wrist tests were sometimes difficult to explain to a young child because of confusion distinguishing between hand and wrist motions. For such children, the child's hand was unstrapped and the tester substituted her finger for the test fixture. By grasping the tester's finger, the child was guided through the desired motion. This was done several times and the child was requested to demonstrate the desired motion. In this manner, the tester could actually feel

whether the child understood the motion being requested. The child's hand was then strapped back into position and the test performed.

The order of testing was accomplished so that major muscle groups of an extremity were not tested sequentially. That is, an upper extremity test would be performed, followed by a lower extremity test which allowed a greater time for muscle groups to metabolically recover after an exertion. Thus the strength tests were felt to be relatively independent of fatigue factor based upon the time during the test at which a particular function was measured. Under exceptional circumstances, a child might seem unable to satisfactorily perform a test even after 3 or 4 attempts. In such a case the test was omitted.

In addition to strength testing as described above, complete anthropometric measurements of the linkages outlined in Section 3.3 were obtained on each child in the study.

To promote a constant flow of subjects during the day and maximize the number of tests which could be obtained, a second child was usually brought into the room before one child finished the sequence of tests. In some circumstances, depending upon classroom schedules, naps, lunches, recesses, etc., children were measured without this preconditioning.

Because of the restricted amount of time for individual testing, as well as the duration of the school day which limited the number of children who could be tested, variable numbers of children were measured at nursery schools and

elementary schools. Typically, 10-15 children per day were tested in the nursery schools and 15-19 children per day were tested in the elementary schools. Both of these numbers are for a limited set of tests, as outlined in Appendix 4.3.

In the Child Strength Laboratory, 6-10 children per day were tested. Again, a constant flow of children could not always be maintained. Usually, two children (often siblings) were scheduled during the same time block, making it possible to use the time more efficiently.

Because of the number of tests being done, the child was placed in the chair twice with a rest period in-between. During the rest period, the child had a snack of graham crackers and juice and could color, read, relax or observe the general activity. The atmosphere seemed to impress the children and testing was felt to be a pleasant experience.

2.9.2 Motivation

The degree of motivation can significantly influence results obtained from strength testing in childhood. In order to insure a high level of involvement, the psychological aspects of the testing procedure were carefully considered.

The participation of a child in this study was completely voluntary. No child was tested who did not want to be tested. No child was placed in the chair who seemed fearful. A positive atmosphere was developed through friendly testers, a clear explanation of what the child would be expected to do, the opportunity to "make a picture on the TV screen" by completing each test, a chance to relax between test sessions

with a snack such as crackers and juice, and usage of a play area which was partitioned off from the testing area, complete with puzzles, books and toys. The lab was decorated with animal posters and many drawings done by other subjects. This not only increased cooperation, but overcame any initial hesitation.

The child was able to touch and sit in the chair before being measured or tested and was not rushed through initial procedures. For example, one afternoon a woman came in with her two children, a six year old boy who was very curious about our chair, and a three year old girl who was so skeptical that she would not enter the lab. While the testers explained the procedure to her brother and mother, taking care to be sure she could hear and see the chair from her position in the hallway, she began to move a little closer. She came still closer to see her brother becoming acquainted with the "TV screen", the toys, and the crayons. After five minutes she was inside, sitting on her mother's lap, watching her brother show how strong he was, and waiting for her turn. All this was without any convincing or persuading by her mother or the testers.

Children were intrigued by the computer, the strength testing chair, and especially the graphics terminal. One of the testers continually encouraged the child, explaining each test, demonstrating if necessary, and checking to see that the child was comfortable and attentive. Depending on the wishes of the parent or the child, parents were

present in the lab as the child was tested, and able to sit near him or her. Whenever possible, a child was tested with a sibling, a friend or another child present. This not only clarified what was to be expected but showed them the tests were not difficult, and provided an incentive to "make pictures on the TV screen" to show "how strong" they were. The testers also told the children they should be as strong as they could, because the chair was built to be very safe and strong, and this was one place they could push or pull as hard as possible.

To help defray travel costs, babysitting expenses, and time spent, most subjects tested in the lab received reimbursement of \$5.00 after each session. Some children found this quite motivating, others did not; still others had not been told by their parents. This factor was extremely important in being able to recruit subjects and in maintaining parental interest and motivation.

Occasionally, after observing the graphics display, the tester chose to repeat a particular test. After having the tests explained again and any necessary adjustments made, a child would often comment on how much better he had performed on the second test. Sometimes a child would ask if he could repeat a certain test. On the basis of facial reactions and comments from the child, testers were able to ascertain that he left the testing session feeling he had done a good job and was strong. As a measure of their esteem, the subjects have left behind over 100 pictures of smiling animals, clowns, computer terminals, etc. that they drew in our laboratory.

2.10. Data Reduction and Analysis

Description of the data acquisition program has already been presented (Section 2.3.). For the population survey, this program was used to generate well over a hundred magnetic tapes filled with data files on each subject tested. Each file represents a permanent "time" record of a subject's tests, making it possible to analyze the data via any method desired.

For quantitative and statistical analysis of the data, a series of processing and reducing programs was written and utilized. The first reduction program condensed each data file into a more compact and analyzable form, coding the subject's background information and replacing the 400 data points for each test with four calculated strength values, based on the one-second-moving-point-average technique (Section 2.1.). Reduced files were then transmitted to the University of Michigan's AMDAHL 470 computer for further processing and statistical analysis. The contents of such a reduced file are presented in the Appendix (Section 4.4.).

Since many of the subjects had been tested on more than one occasion, it was necessary to bring all of the data for each child together. This was accomplished by collating programs which merged each subject's test sessions. In most cases, different tests were performed during different sessions; however, if the same test were repeated in one or more testing sessions, the test with the larger strength value was chosen.

Ages were computed at this time by subtracting the birth-date from the date of the subject's most recent testing session. Ages were represented internally in days and were computed using the approximation of 365 days to the year and 30 days to the month. Ages computed in this fashion are never more than seven days in error, which was sufficient resolution for the purposes of this study. As mentioned before, some subjects were tested in more than one session. Usually these sessions were on the same day and in most cases not more than a week apart.

Data was then analyzed statistically using the Michigan Interactive Data Analysis System (MIDAS), a comprehensive set of statistical analysis programs developed by the Statistical Research Laboratory of the University of Michigan. For the purposes of analysis, subjects were grouped into 8 yearly age groups, from 3 to 10 years. Ages were rounded to the nearest whole year so that altogether an age range of 2.5 to 10.5 years was represented. Out of the 502 subjects measured, only 498 fell within the required age limits. The remaining four subjects were omitted from the analysis. Each of the 33 strength and 14 linkage measurements were analyzed by age for the following quantities: number of subjects (N), mean (\bar{X}), Standard Deviation (S_x), median, 10th percentile, 90th percentile, minimum value, and maximum value. (Body weight was included here as a linkage measurement.) Although 5th and 95th percentiles are usually reported, sample sizes for certain age groups in this study were not large enough to contain these percentiles, thus, the 10th and

90th percentiles were chosen as more meaningful statistics. The above analysis was performed over three different sets of data: for the complete set of subjects, for males only, and for females only. The results of these analyses are reported in tabular form in Section 3.

For the purpose of creating a graphical description of the data, least squares polynomial regressions describing strength or linkage vs age were performed over each test for the three cases of males, females, and combined sexes. For these purposes, subjects were not grouped by age. Rather, age was treated as a continuous independent variable. Polynomial regressions of first through sixth order were produced for a subset of the tests and plotted along with scatter plots of the actual data. An example of such a plot is shown in Figure 20. It was found in each sample curve that terms of higher than fourth order contributed little to the fit of the data and in some cases introduced perturbations to the curves which were not believed to be the result of any real strength variation but rather of insufficient sample size. Conversely, curves resulting from regressions of less than fourth order did not seem to fit the data as well, especially near the end points of the age interval. Regressions of third and lower order had significantly higher standard errors in some of the sample tests. For these reasons, it was decided that regressions of fourth order would be performed on all strength tests and linkages. A precedent for this choice exists in the Child Measurement Study (National Technical Information Service [NTIS]

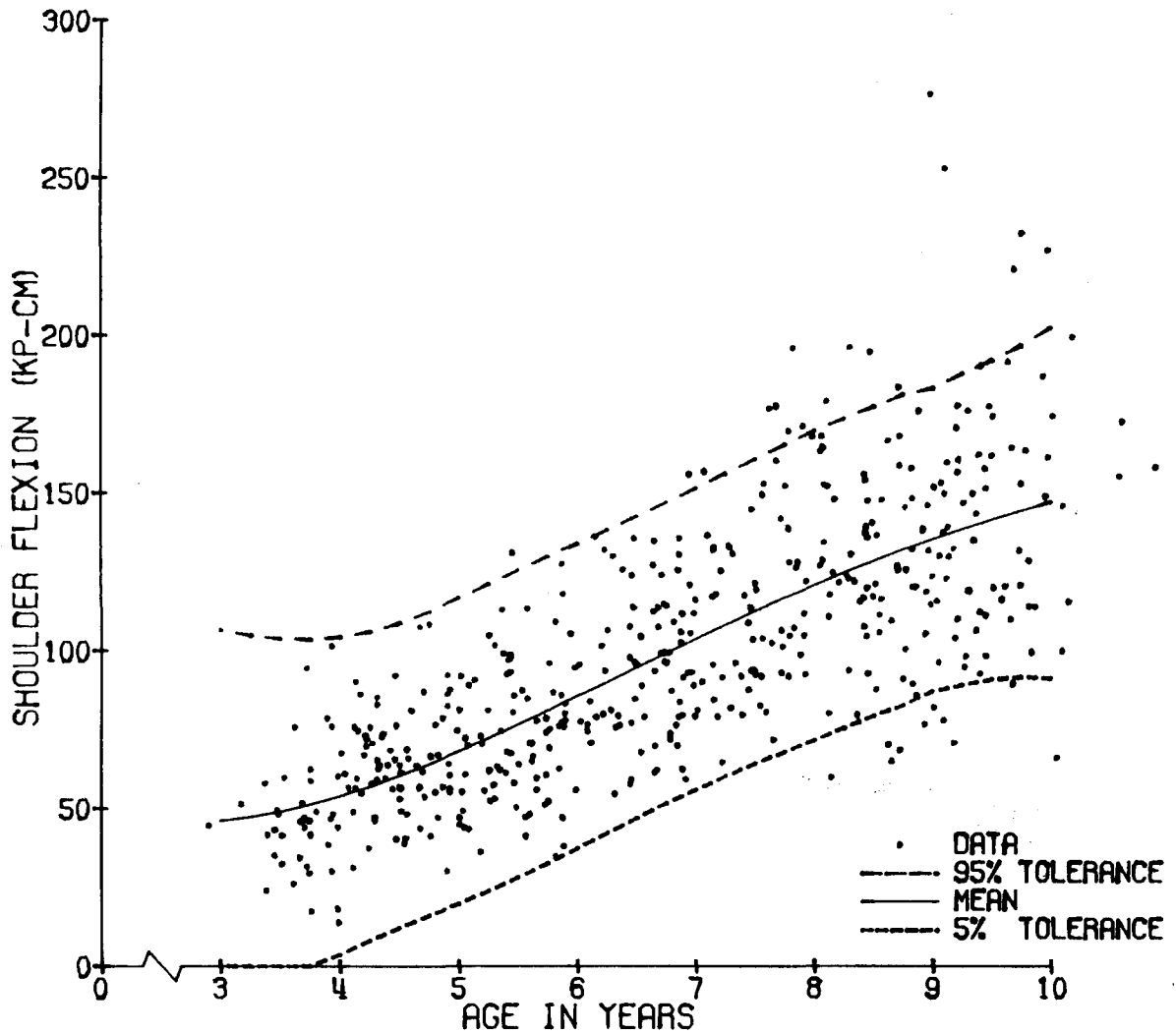

Figure 20 Scatter Plot of data with Fourth Order Polynomial Fit

publication number: PB-242- 221), for which fourth order regressions were chosen as well. (See Figure 21.)

In order that the graphical presentations might display the spread of the data from the mean, tolerance intervals were computed for the age range in question using standard errors computed from the residuals resulting from the regression analyses,

as well as information from the actual data including measures of sample size and the degree of homogeneity of measured ages across the age range. Tolerances were computed at the 5% and 95% levels with a confidence of 95%. This means that, with 95% certainty, 90% of the population will fall within the two tolerance bands. Section 3 contains plots of means (fourth order polynomials) and their associated 5% and 95% tolerance limits for each strength test and linkage for the cases of males, females, and combined sexes.

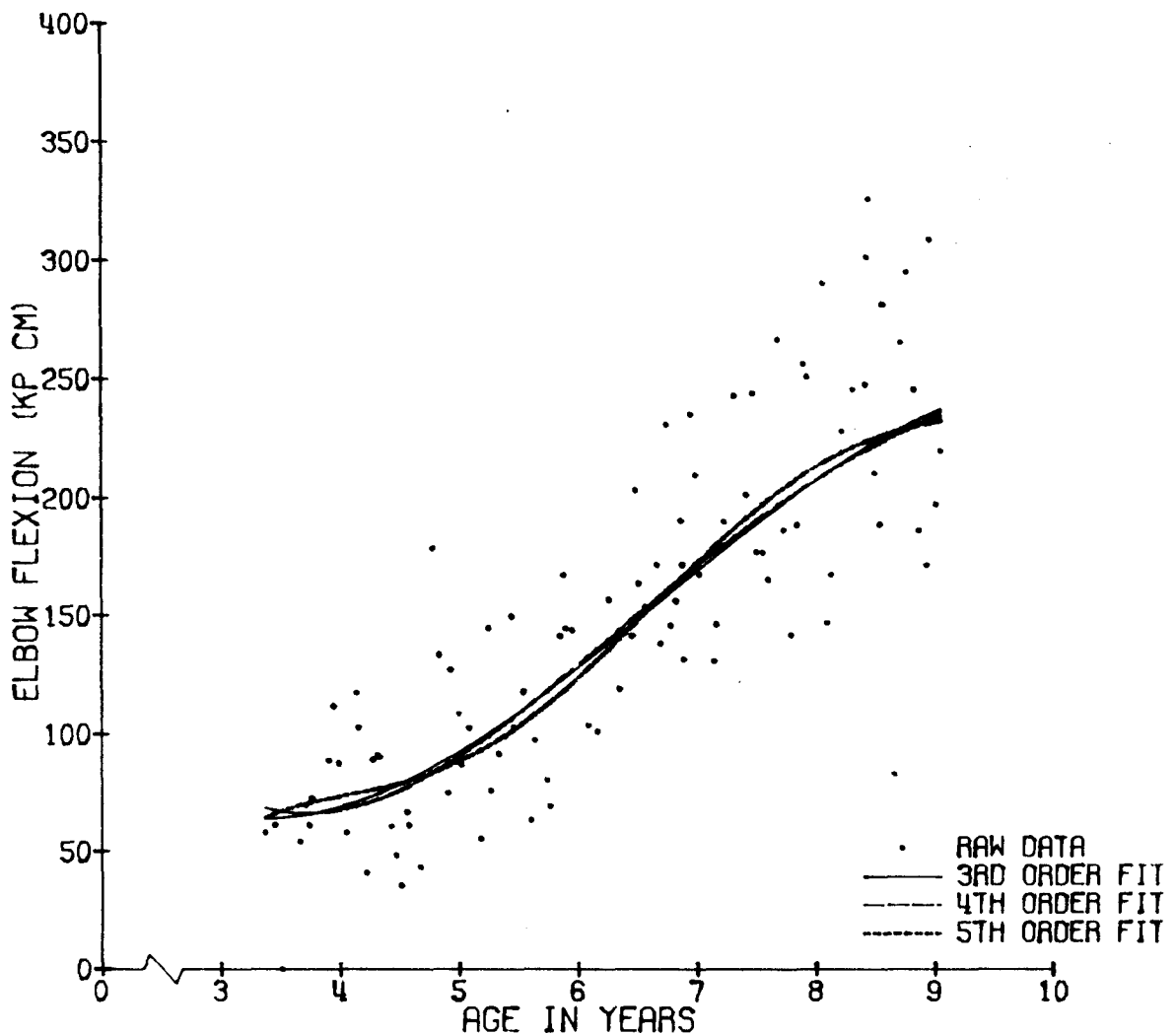

Figure 21 Scatter Plot of Data with 3rd, 4th, and 5th Order Polynomial Fit

3.0 RESULTS

3.1. Description of Data Presentation

The following sections present a summary of the data for each of the 33 strength tests and the 14 linkage measurements. Information on the interpretation of strength data is followed by 33 four-page modules which contain the data collected in the population survey. Each module consists of: A description of the test, the anthropometric measurements taken, adjustment of the equipment, and instructions to the subject. A photograph of the subject performing the test and a drawing which illustrates the motion are included for clarity. A statistical tabulation of the data including the sample size (N), the mean (\bar{X}), the standard deviation (S_x), the minimum, 10th percentile, median, 90th percentile, and maximum values are tabulated by one year intervals. Data for the combined sexes are presented first, followed by a graph of the mean value together with the 5% and 95% tolerance bands. Data are presented in a similar fashion for males and females.

The data are presented for linkage measurements in a similar format. Each of the 14 two-page modules contains a definition of how the measurement was taken along with a photograph and illustration of the measurement. A statistical summary of the data for one year age intervals together with a graphical presentation of the data are given for combined sexes.

3.2. Strength Measurements

3.2.1. Interpretation of Strength Data

3.2.1.1. Physical Relationships and Units: In the following tables and graphs, the strength data are presented in the torque units of kilopond-centimeter or force units of kiloponds (squeeze and pinch tests). Kiloponds (Kp) or kilogram force (Kgf) is defined to be the magnitude of force required to accelerate a mass of 1 kilogram at 1 g (acceleration due to gravity). A kilopond-centimeter (Kp-cm) is defined to be the magnitude of torque generated about an axis of rotation due to the action of a force of 1 kilopond occurring 1 centimeter away at right angles to the axis. These two general relationships may be summarized along with metric units used in the study as follows:

FORCE

From Newton's Second Law Where:

$$F = (m) (a)$$

$$\begin{aligned} F &= \text{force (Newtons)} \\ m &= \text{mass (Kg)} \\ a &= \text{acceleration (M/sec}^2\text{)} \end{aligned}$$

or, in terms of Kiloponds:

$$F = (1/g) (m) (a)$$

$$\begin{aligned} F &= \text{force (Kp)} \\ m &= \text{mass (Kg)} \\ a &= \text{acceleration (M/sec}^2\text{)} \\ g &= \text{acceleration due to} \\ &\quad \text{gravity at the Earth's} \\ &\quad \text{surface} \\ &= (9.80 \text{ M/sec}^2\text{)} \end{aligned}$$

TORQUE

$$T = (F) (D)$$

$$\begin{aligned} T &= \text{torque in (Kp-cm)} \\ F &= \text{force in (Kp)} \\ D &= \text{perpendicular distance} \\ &\quad \text{from force to axis of} \\ &\quad \text{rotation (cm)} \end{aligned}$$

ENGLISH UNITS CONVERSION

1Kp = 2.2046 lbs

1Kp-cm = 0.8679 in-lbs

Notice that 1Kp-cm is only slightly less than 1 in-lb. This is useful in making approximations to the data in English units.

3.2.1.2. Joint Position Dependency: Data for each test must be interpreted for the subject in the "standard test position" (Figures 4,5), since isometric strength varies with the joint position. For strength estimates in other positions, one can only make the assumption that child strength varies with respect to joint position in the same fashion as adult strength, and proceed to extrapolate on that basis.

3.2.1.3. Torque: Data expressed in torque units may be interpreted via the definition of mechanical torque previously mentioned. Each strength value is presented as equivalent to a force times a distance. When a force or force component acting at right angles to the limb at a particular point must be known, it may be calculated by dividing the strength value by the distance to the force from the joint center. For example, an elbow flexion strength of 300 Kp-cm implies that the forearm can generate an upward force of 10 Kp at 30 cm away from the elbow, 15 Kp at 20 cm, 30 Kp at 10 cm, and so on. An estimate of the linkage length can be obtained from Section 3.3. to make an estimate of force

capability for a particular age child. It must be kept in mind, however, that strict mathematical interpretation of torque may be erroneous for extremes of force and distance. In such cases a limitation of capability may be imposed by considerations other than absolute muscle strength. For example, very high loading pressure on the soft tissue can cause pain and thereby limit the strength capability. Also, exceeding the torque loading capability of a proximal joint may result in a limitation of the strength capability.

3.2.1.4. Motivation: Each strength value represents a maximum voluntary effort obtainable through verbal encouragement. It must be recognized that the child is capable of stronger efforts than the data indicate, especially in an excited psychological state. Section 2.9.2. of this report describes in detail motivation used in this study.

3.2.1.5. Strength Criteria: Each strength value is the average torque measured over a one second interval. This one second is selected as the one second interval which has the greatest average value of all possible contiguous one second intervals in a five second exertion. Section 2.6. describes the criteria in more detail.

3.2.1.6. Description of Tests: A precise anatomic definition of the strengths being measured is given

with respect to the anatomic position. Figure 22 shows a subject in the anatomic position with illustration of the sagittal, coronal, and transverse planes together with their axes. Figure 23 contains definitions of terms used. Table I contains the joint angles at which strength may be measured by the strength chair. All joint angles are defined to be zero when the subject assumes the anatomic position and rotates his wrist so that the palms face the thighs.

3.2.1.7. Test Position: The body position is described with respect to the anatomic position and joint angles are defined as zero in the anatomic position but with the wrists pronated so that the palms face the thighs. For a series of tests pertaining to one limb, only relevant joint positions for that limb are given. The rest of the body remains in the standard test position as shown in Figures 4 and 5. Grip and pinch tests are obtained with the right upper extremity unrestrained.

3.2.1.8. Anthropometric Measurement: These measurements are obtained in order to adjust the size of the strength chair and to biomechanically model the subject. These measurements are described in detail in section 3.3.

3.2.1.9. Adjustment of Equipment: The adjustment

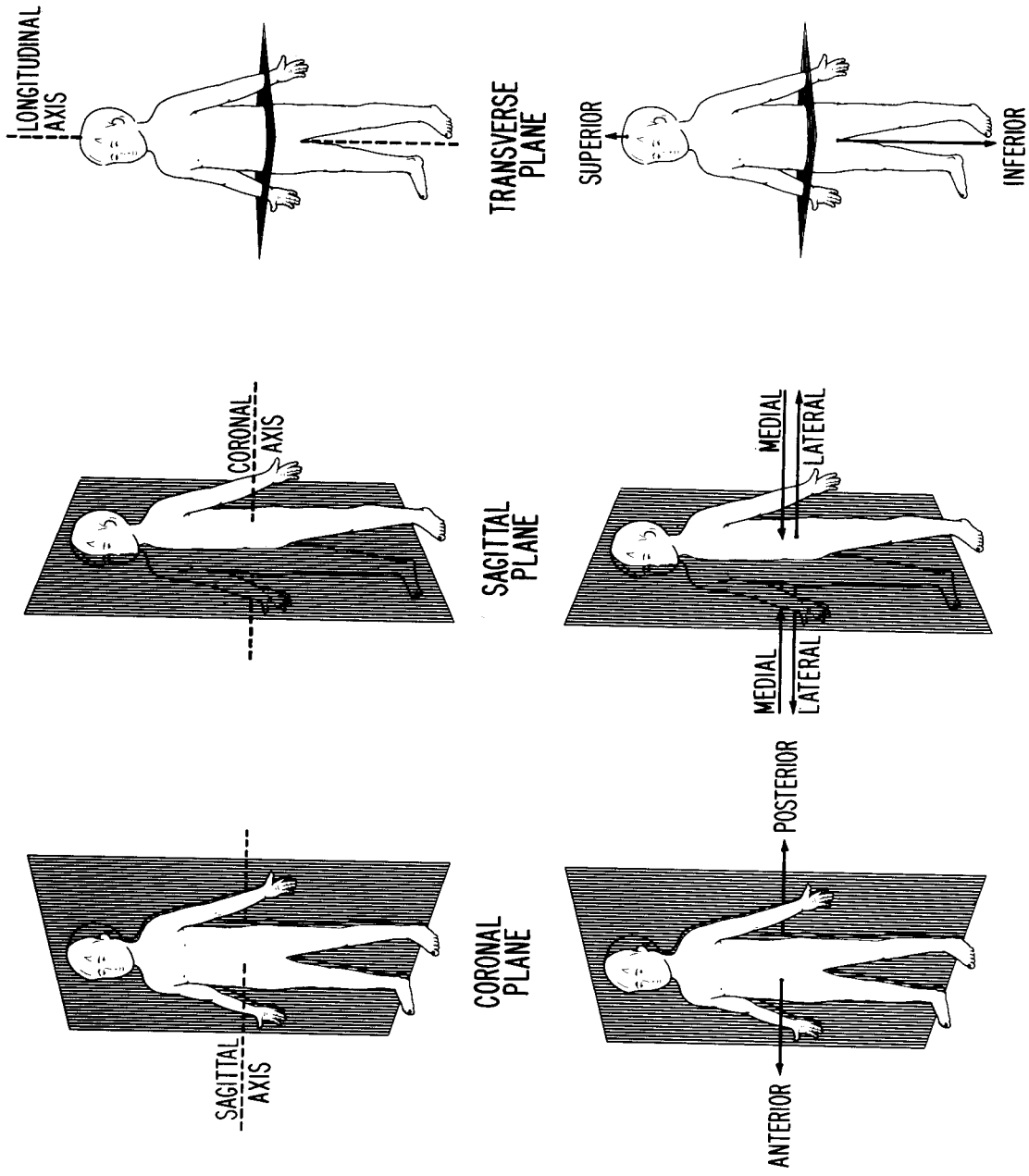

Figure 22 Anatomical Planes, Axes, and Directions

All definitions are made with reference to the Anatomic position:

Erect position with the face forward and the arms at the sides of the body with the palms of the hand forward and the fingers and thumb extended.

Anterior:	Directed toward or situated at the front (Front)
Posterior:	Directed toward or situated at the back (Back)
Superior:	Above or over another body position or reference point (Up)
Inferior:	Below or under another body position or reference point (Down)
Lateral:	Away from the midline of the body (Out)
Medial:	Toward the midline of the body (In)
Midline:	Point at which the sagittal plane intersects with the body
Rotate:	Move the bone about a central axis
Sagittal Plane:	Vertical plane which extends from front to back and divides the body into right and left sides
Coronal Plane:	Vertical plane which extends from side to side and divides the body into anterior and posterior (front and back sides)
Transverse Plane:	Horizontal plane which extends from side to side and front to back and divides the body into upper and lower (cranial and caudal)

Figure 23 Anatomic Terms

TABLE I

STRENGTH CHAIR JOINT POSITION CAPABILITIES

<u>Strength Test</u>	<u>Joint Angle (Degrees)*</u>
Wrist Flexion/Extension	0
Wrist Adduction/Abduction	0
Wrist Pronation/Supination	0
Elbow Flexion/Extension	0, 22.5, 45, 67.5, <u>90</u> , 112.5
Shoulder Flexion/Extension	<u>0</u> , 22.5, 45, 67.5
Shoulder Adduction/Abduction	<u>5</u> , 22.5, 45, 67.5
Shoulder Medial/Lateral Rotation	0
Snkle Flexion/Extension	0
Knee Flexion/Extension	0, 22.5, 45, 67.5, <u>90</u>
Knee Medial/Lateral Rotation	0
Hip Flexion/Extension	22.5, 45, 67.5, <u>85</u> , 90
Hip Adduction/Abduction	0
Hip Medial/Lateral Rotation	0
Trunk Flexion/Extension	0
Grip - 2,3,5 Point and Lateral Pinch	20 mm Finger Tip Spacing
Grip - Squeeze	0.5 to 2.5 cm Handle Span

*All joint angles defined to be zero when subject is standing, arms at side, palms turned toward thighs (Anatomic position with wrist pronated so palms face medially).

NOTE: Where more than one angle is indicated, underlined positions only were used in this study.

procedure necessary to fit the strength chair to a particular child is given. This is intended to help describe the system of body restraints provided by the strength chair.

3.2.1.10. Instructions to the Subject: The specific test instructions are given to the subject depending upon his or her level of comprehension. This section contains a condensed and stylized version of these instructions and does not reflect attempts to motivate the child. The topic of motivation is discussed in Section 2.2.3.

3.2.1.11. Photograph of Test: A photograph of a child performing the test is presented to illustrate both the position of the child and the relevant straps on the fixture. The photographs are not intended to have any implications of the subject's motivation.

3.2.1.12. Sketch of Test: A drawing is presented to clarify the description of the test by illustrating, with some exaggeration, the motion attempted in performing the test. The child begins the test with the body in the position indicated by the dotted lines and performs an exertion so as to attempt to move the body to the position shown by the solid lines.

3.2.1.13. Statistical Data: The page heading consists of a test name and a joint angle position as defined

in Table I . The data are presented by age group from 3 to 10 years. The age in years was found by rounding the age to the nearest year. That is, a child of 3 years, 5 months is classified as a 3 year old while a child of 3 years, 7 months is grouped with the 4 year olds. A total of 502 subjects were measured but 4 were excluded since they fell outside the age range of 2.5 to 10.5 years.

The number of subjects actually performing a test varies for several reasons. Students measured in nursery and elementary schools could be tested for only a limited period of time. Thus, not every test could be performed on all subjects. The order of priority for testing is given in Appendix 4.3. The 10th and 90th percentiles were reported since the sample size in some age groups was insufficient to obtain a 5th or 95th percentile.

3.2.1.14. Graphs: The plotted curves represent the mean value, 5% tolerance bound, and 95% tolerance bound for the combined sexes. The plotted curves for males and females contain only the mean value. In all cases, the curves representing the mean are fourth order polynomial fits to the data with age in days as the independent variable, assuming that one year equals 365 days. The tolerance bounds are computed by assuming that the data has a Gaussian (normal) distribution for each age.

It should be clearly understood that the graphical presentation, including the polynomial fit and the 5th and 95th tolerance bounds are meant as an overview and not for any computational interpretation. Use of the data for setting standards or product design requires consideration and statistical implementation of the tabular presentation. For most strength measurements, the tolerance bounds are overestimates of the middle 90% for younger children (3-4 year olds) and are underestimates of the older children (9-10 year olds). See Figure 20, which displays a scatter plot of the data and the associated curves. This phenomenon is the result of the heteroscedasticity inherent in the measurements (i.e. the standard deviation increases with increasing age). We were reluctant to attempt data transformations (e.g. square root transformation) to make the data more homoscedastic, because of the difficulty of justifying such data manipulation for the strength measures.

3.2.2. Index of Strength Data

<u>Measurement</u>	<u>Page</u>
1. Wrist Flexion	76
2. Wrist Extension	80
3. Wrist Adduction	84
4. Wrist Abduction	88
5. Wrist Pronation	92
6. Wrist Supination	96
7. Elbow Flexion	100
8. Elbow Extension	104
9. Shoulder Flexion	108
10. Shoulder Extension	112
11. Shoulder Adduction	116
12. Shoulder Abduction	120
13. Shoulder Medial Rotation	124
14. Shoulder Lateral Rotation	128
15. Ankle Flexion	132
16. Ankle Extension	136
17. Knee Flexion	140
18. Knee Extension	144
19. Knee Medial Rotation	148
20. Knee Lateral Rotation	152
21. Hip Flexion	156
22. Hip Extension	160
23. Hip Adduction	164
24. Hip Abduction	168
25. Hip Medial Rotation	172
26. Hip Lateral Rotation	176
27. Trunk Flexion	180
28. Trunk Extension	184
29. Grip - 2 pt. Pinch	188
30. Grip - 3 pt. Pinch	192
31. Grip - 5 pt. Pinch	196
32. Grip - Lateral	200
33. Grip - Squeeze	204

WRIST FLEXION

DESCRIPTION OF TEST: The hand is rotated anteriorly at the wrist joint (radiocarpal joint center) in the sagittal plane, moving the palm superiorly toward the flexor surface of the forearm.

TEST POSITION: The shoulder is abducted 5° , elbow flexed 90° , and wrist neutral at 0° . The right hand grasps a 2.5 cm diameter handle, the left forearm (distal to the humero-ulnar joint center) is unrestrained.

ANTHROPOMETRIC MEASUREMENTS: The carpal, radial, humeral, sacral and thoracolumbar linkages are measured with an anthropometer.

ADJUSTMENT OF EQUIPMENT: The chair back fixture is set to the sacral plus thoracolumbar length, aligning the shoulder joint center with that of the chair. The chair arm fixtures are set to the humeral and radial plus carpal lengths, aligning the elbow joint center and center of grip with those of the chair. Thin rubber pads are placed under the arm as needed to maintain these alignments. The shoulder abduction angle is locked at 5° and elbow flexion at 90° . The distal edge of the wrist support is adjusted to align with the wrist joint center. The wrist and arm straps are then secured snugly around the arm and the chest strap around the chest and left forearm. The subject's right hand is placed to grasp the handle on the chair. His left forearm is placed in his lap.

INSTRUCTIONS TO SUBJECT: The child pulls his hand toward his body and his wrist away from his body.

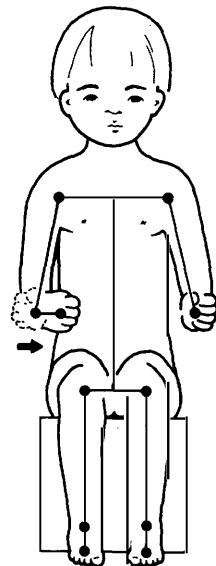
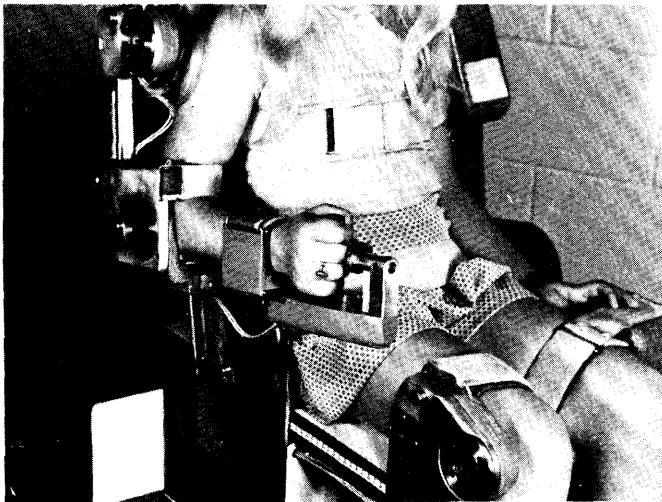

WRIST FLEXION, J DEG. (KP-CM)

COMBINED SEXES

AGE	N	MEAN	ST. DEV	MIN	10%	MEDIAN	90%	MAX
3	7	8.6	4.8	2.4	2.4	8.6	17.1	17.1
4	34	12.4	6.2	2.7	4.5	12.1	20.5	24.6
5	30	15.5	8.0	5.2	6.6	14.9	24.6	38.3
6	39	22.8	8.7	4.3	12.9	21.4	38.0	43.6
7	30	27.3	10.7	9.1	16.3	24.0	42.2	58.9
8	27	35.9	13.0	16.6	21.6	32.2	51.5	69.3
9	29	46.2	19.2	9.5	24.2	43.0	76.2	81.8
10	15	44.2	16.9	23.4	23.6	39.4	68.7	71.4

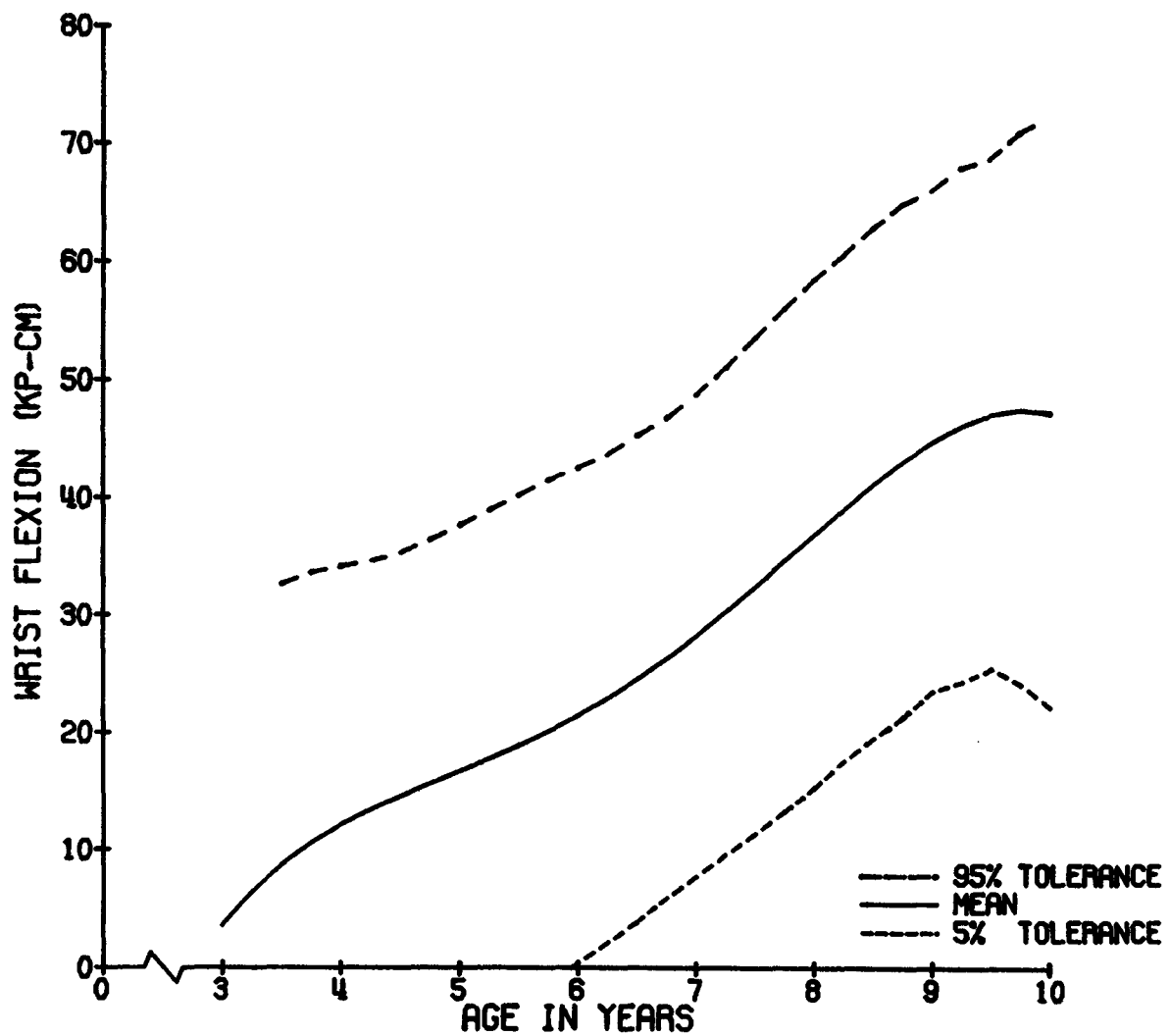

WRIST FLEXION, 0 DEG. (KP-CM)

MALES

AGE	N	MEAN	ST. DEV	MIN	10%	MEDIAN	90%	MAX
3	5	10.0	4.7	4.2	4.2	8.9	17.1	17.1
4	16	13.1	6.6	2.7	5.4	13.2	22.4	24.6
5	9	15.3	11.9	5.2	5.2	9.3	38.3	38.3
6	25	23.2	9.4	4.3	12.9	21.4	38.0	43.6
7	14	32.3	12.8	16.3	17.6	29.8	50.9	58.9
8	17	35.7	13.1	16.6	21.6	31.3	50.6	69.3
9	12	53.4	17.0	28.2	34.4	51.4	76.2	81.8
10	7	49.9	17.5	31.8	31.8	53.7	71.4	71.4

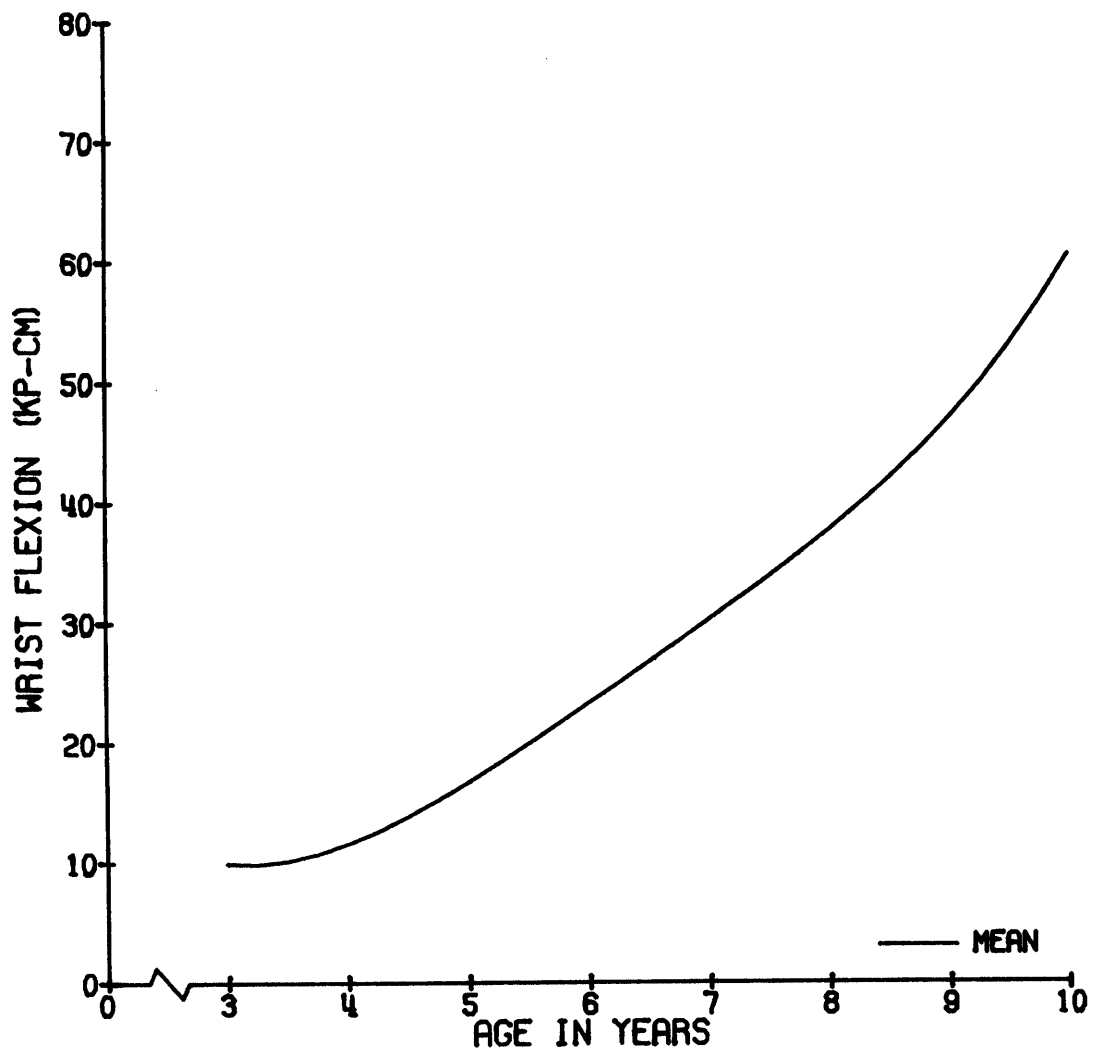

WRIST FLEXION, ° DEG. (KP-CM)

FEMALES

AGE	N	MEAN	ST. DEV	MIN	10%	MEDIAN	90%	MAX
3	2	5.0	3.7	2.4	2.4	5.0	7.6	7.6
4	18	11.8	6.0	4.2	4.5	11.2	20.2	23.2
5	21	15.6	6.1	6.6	10.3	15.3	21.3	33.0
6	14	22.3	7.7	11.2	13.2	21.3	30.2	41.7
7	16	22.9	6.0	9.1	14.8	22.6	30.7	36.7
8	10	36.3	13.5	17.7	17.7	35.0	51.5	61.9
9	17	41.2	19.4	9.5	13.0	41.8	71.6	80.3
10	8	39.2	15.8	23.4	23.4	39.1	68.3	68.3

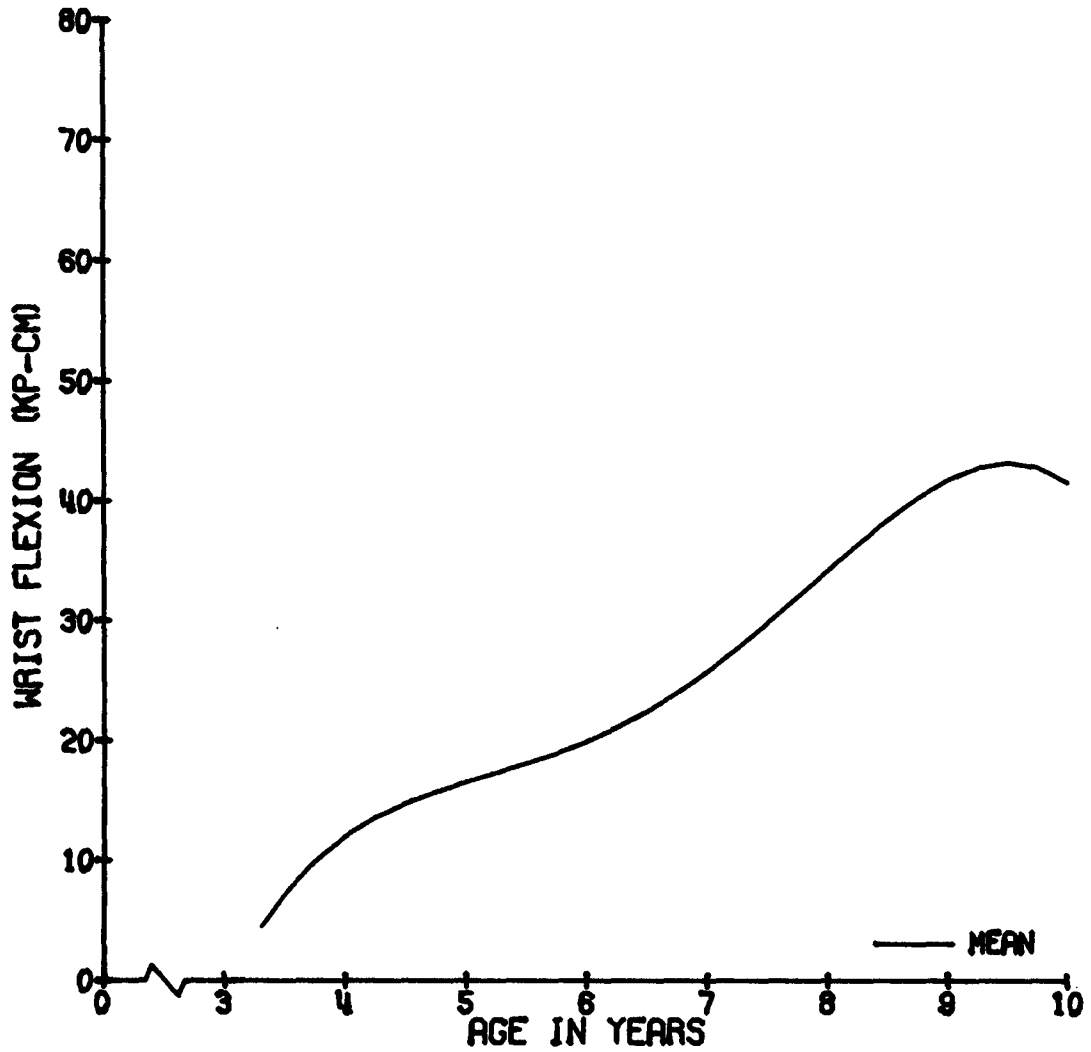

WRIST EXTENSION

DESCRIPTION OF TEST: The hand is rotated posteriorly at the wrist joint (radiocarpal joint center) in the sagittal plane, moving the palm inferiorly away from the flexor surface of the forearm.

TEST POSITION: The shoulder is abducted 5° , elbow flexed 90° , and wrist neutral at 0° . The right hand grasps a 2.5 cm diameter handle, the left forearm (distal to the humero-ulnar joint center) is unrestrained.

ANTHROPOMETRIC MEASUREMENTS: The carpal, radial, humeral, sacral, and thoracolumbar linkages are measured with an anthropometer.

ADJUSTMENT OF EQUIPMENT: The chair back fixture is set to the sacral plus thoracolumbar length, aligning the shoulder joint center with that of the chair. The chair arm fixtures are set to the humeral and radial plus carpal lengths, aligning the elbow joint center and center of grip with those of the chair. Thin rubber pads are placed under the arm as needed to maintain these alignments. The shoulder abduction angle is locked at 5° and elbow flexion at 90° . The distal edge of the wrist support is adjusted to align with the wrist joint center. The wrist and arm straps are then secured snugly around the arm and the chest strap around the chest and left upper arm. The subject's right hand is placed to grasp the handle on the chair. His left forearm is placed in his lap.

INSTRUCTIONS TO SUBJECT: The child pushes his hand away from his body and his wrist toward his body.

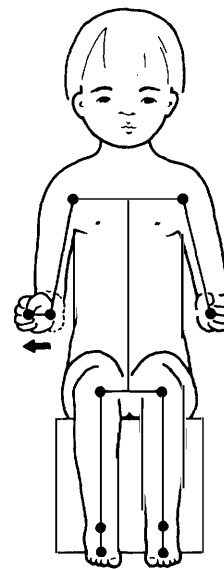
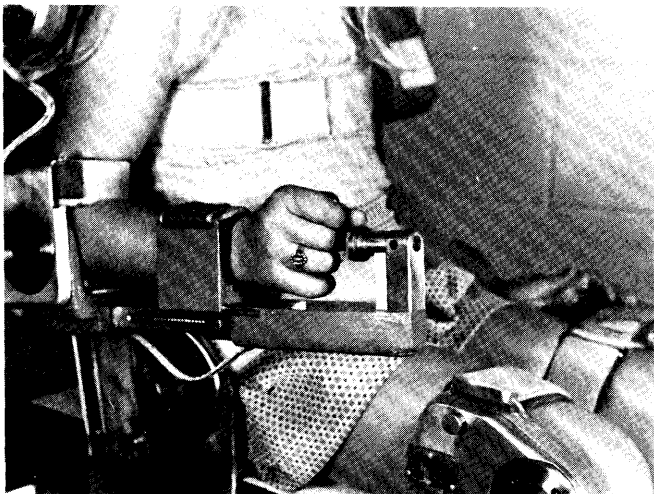

WRIST EXTENSION,) DEG. (KP-CM)

COMBINED SEXES

AGE	N	MEAN	ST. DEV	MIN	10%	MEDIAN	90%	MAX
3	6	6.4	2.2	4.3	4.3	5.9	10.1	10.1
4	33	5.2	2.8	1.4	2.7	5.7	10.6	11.5
5	29	7.0	3.1	2.6	3.6	6.5	13.3	14.6
6	37	9.2	4.1	3.9	4.4	8.5	13.4	26.5
7	29	11.5	4.8	2.8	5.7	10.7	18.1	22.6
8	27	12.4	4.5	3.8	7.5	11.6	17.7	24.2
9	29	17.0	7.5	3.6	8.0	16.9	25.8	37.7
10	15	16.7	4.2	7.9	10.6	16.6	23.2	23.4

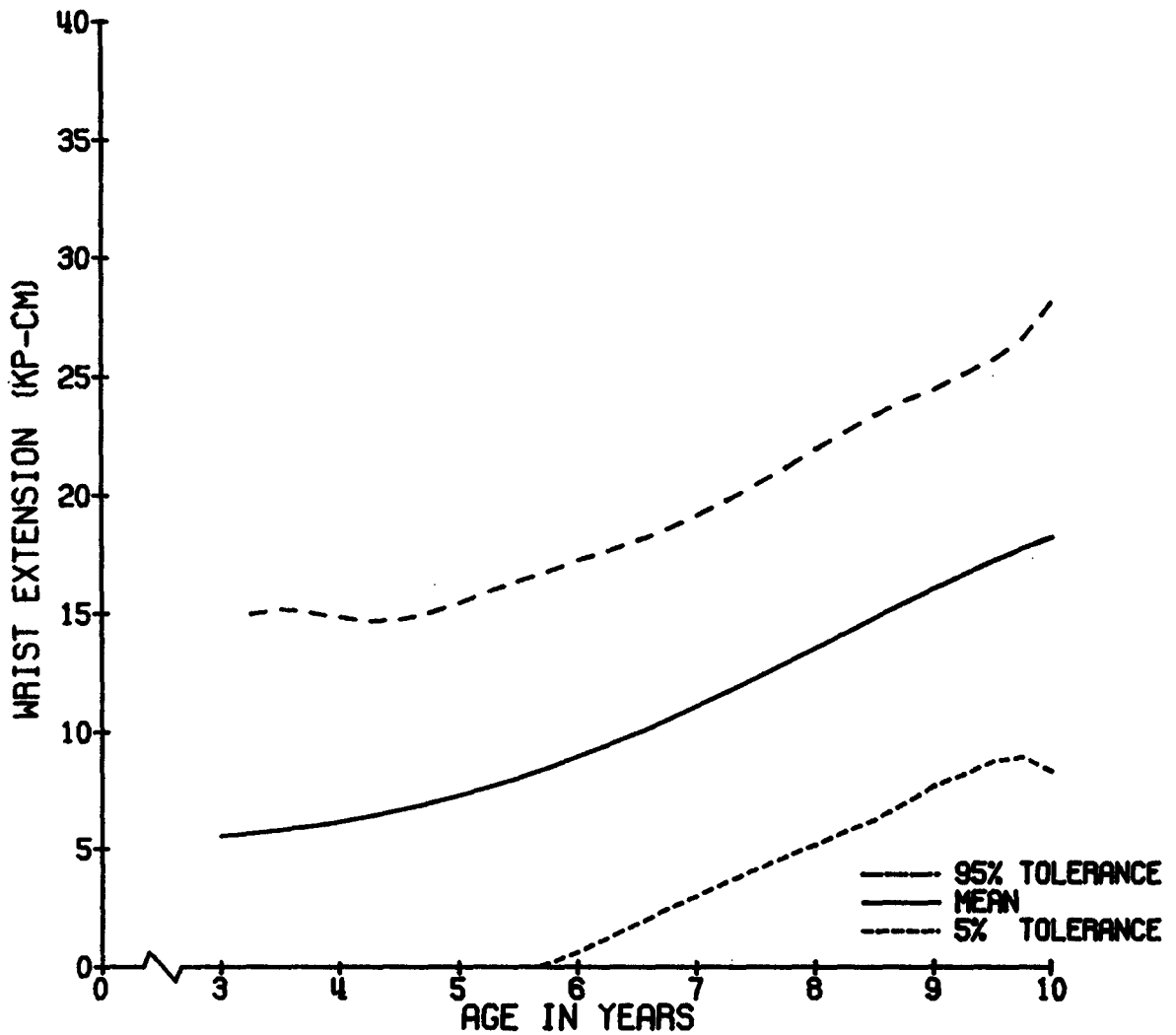

WRIST EXTENSION, J DEG. (KP-CM)

MALES

AGE	N	MEAN	ST. DEV	MIN	10%	MEDIAN	90%	MAX
3	4	7.3	2.1	5.2	5.2	7.0	10.1	10.1
4	15	7.1	2.9	2.5	2.7	6.6	11.5	11.5
5	9	6.1	3.1	2.9	2.9	4.8	13.3	13.3
6	24	9.4	4.7	4.1	4.4	8.8	13.4	26.5
7	13	13.9	5.6	5.7	8.2	12.0	21.4	22.6
8	17	12.5	4.0	7.5	8.4	11.5	15.5	24.2
9	12	20.8	7.7	10.9	11.2	19.8	28.8	37.7
10	7	17.6	3.3	13.6	13.6	17.2	23.2	23.2

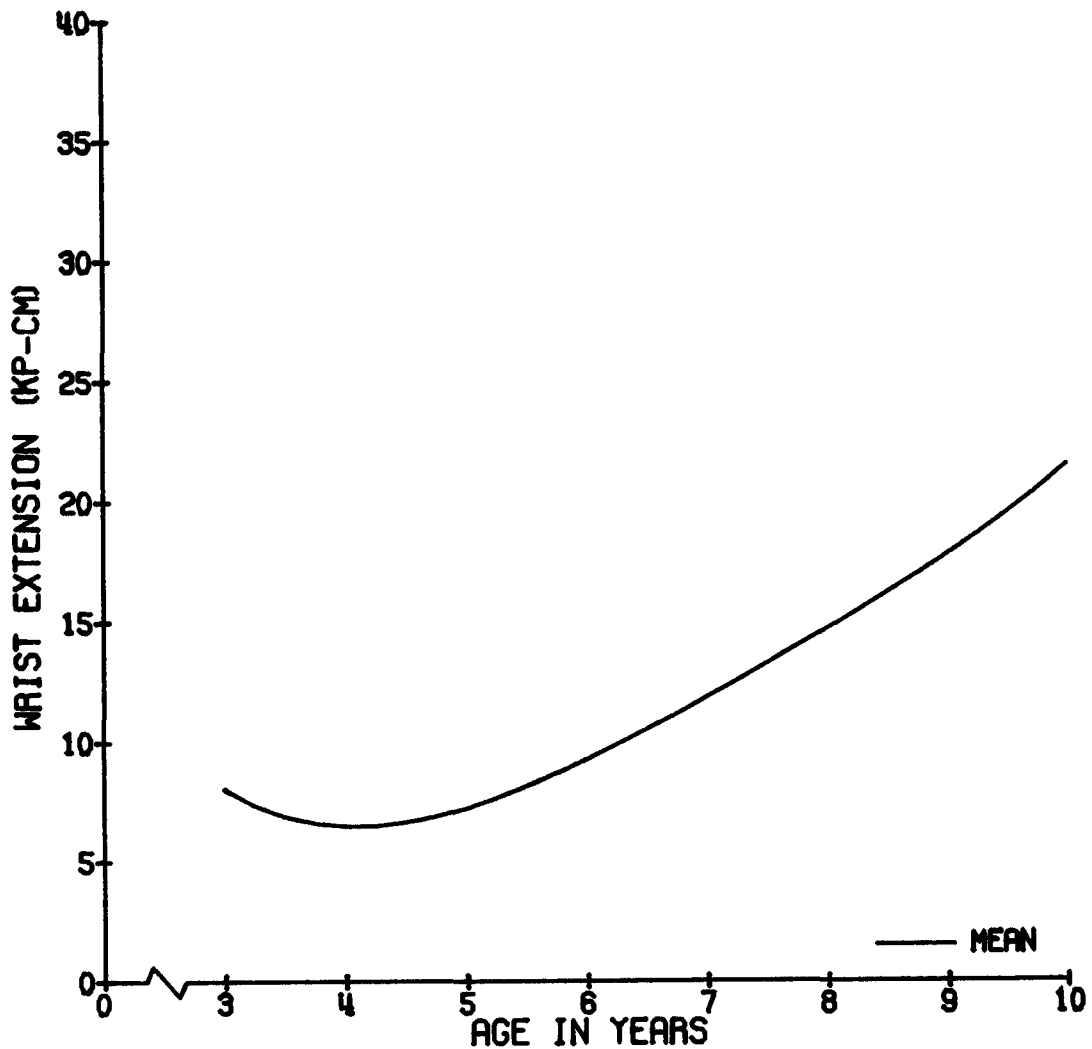

WRIST EXTENSION, 0 DEG. (KP-CM)

FEMALES

AGE	N	MEAN	ST. DEV	MIN	10%	MEDIAN	90%	MAX
3	2	4.5	0.3	4.3	4.3	4.5	4.7	4.7
4	18	5.4	2.6	1.4	1.9	5.1	9.5	11.3
5	20	7.4	3.2	2.6	3.6	7.6	9.7	14.6
6	13	8.9	2.9	3.9	6.3	7.9	12.3	14.4
7	16	9.6	3.1	2.8	5.4	9.8	13.7	14.6
8	10	12.2	5.4	3.8	3.8	12.6	17.7	17.9
9	17	14.2	6.2	3.6	6.3	14.4	23.4	24.0
10	8	15.9	4.9	7.9	7.9	16.5	23.4	23.4

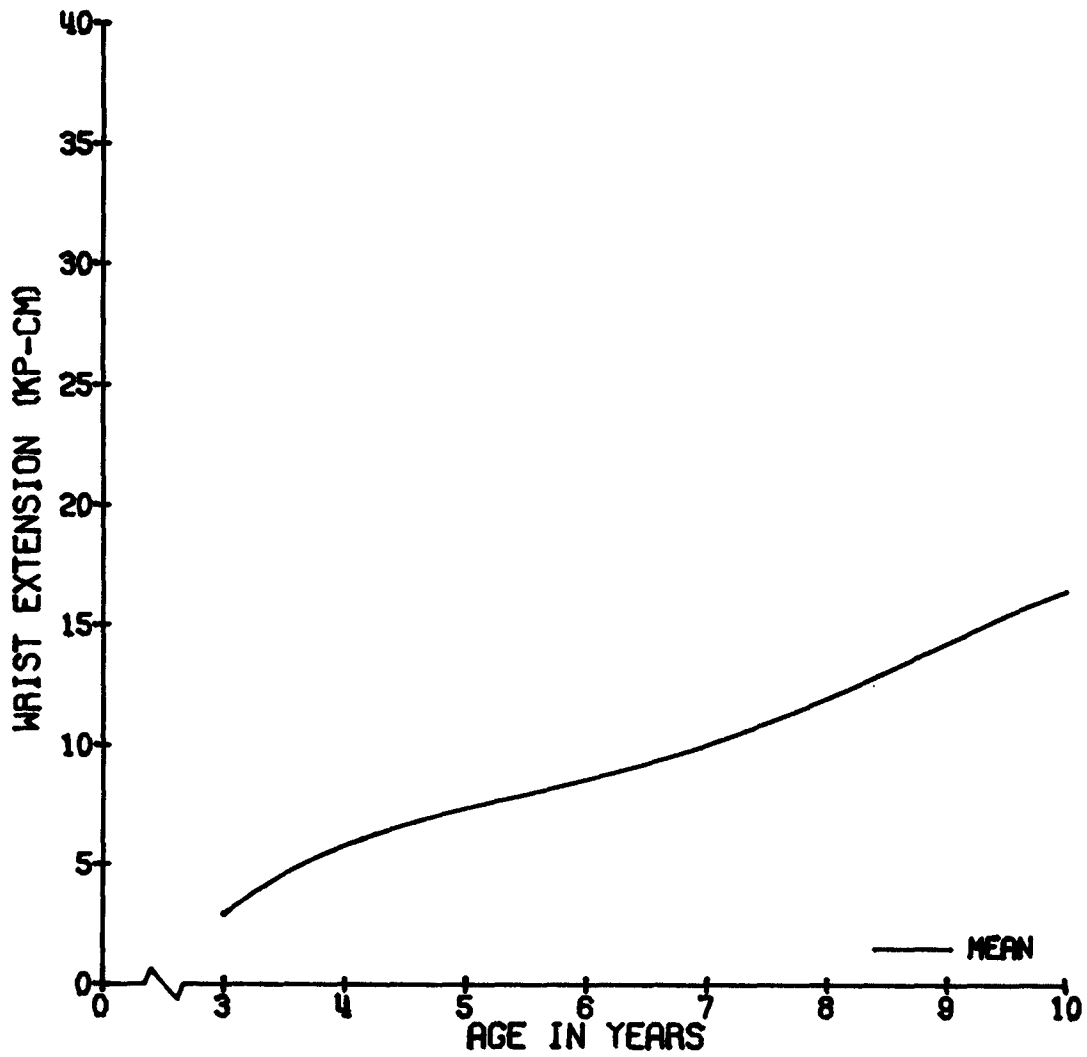

WRIST ADDUCTION

DESCRIPTION OF TEST: The hand is rotated medially at the wrist joint (radiocarpal joint center) in the coronal plane.

TEST POSITION: The shoulder is abducted 5° , elbow flexed 90° , and wrist neutral at 0° . The right hand grasps a 2.5 cm diameter handle, the left forearm (distal to the humero-ulnar joint center) is unrestrained.

ANTHROPOMETRIC MEASUREMENTS: The carpal, radial, humeral, sacral and thoracolumbar linkages are measured with an anthropometer.

ADJUSTMENT OF EQUIPMENT: The chair back fixture is set to the sacral plus thoracolumbar length, aligning the shoulder joint center with that of the chair. The chair arm fixtures are set to the humeral and radial plus carpal lengths, aligning the elbow joint center and center of grip with those of the chair. Thin rubber pads are placed under the arm as needed to maintain these alignments. The shoulder abduction angle is locked at 5° and elbow flexion at 90° . The distal edge of the wrist support is adjusted to align with the wrist joint center. The wrist and arm straps are then secured snugly around the arm and the chest strap around the chest and left upper arm. The subject's right hand is placed to grasp the handle on the chair. His left forearm is placed in his lap.

INSTRUCTIONS TO SUBJECT: The child pushes his hand down and his wrist up.

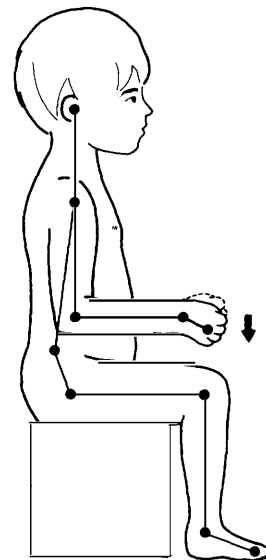

WRIST ADDUCTION, 0 DEG. (KP-CM)

COMBINED SEXES

AGE	N	MEAN	ST. DEV	MIN	10%	MEDIAN	90%	MAX
3	7	10.1	5.3	5.4	5.4	9.4	19.2	19.2
4	34	14.7	7.2	4.1	7.3	14.7	24.5	32.4
5	30	18.5	8.1	4.8	9.4	16.8	26.7	39.4
6	36	23.0	7.3	7.9	12.9	22.9	33.2	35.6
7	28	28.0	10.5	7.2	16.5	25.8	44.3	52.1
8	28	31.7	9.9	14.1	20.0	30.1	49.7	52.7
9	28	35.0	13.7	14.5	16.8	35.1	57.1	61.3
10	14	34.7	15.5	15.4	19.3	31.9	53.8	76.7

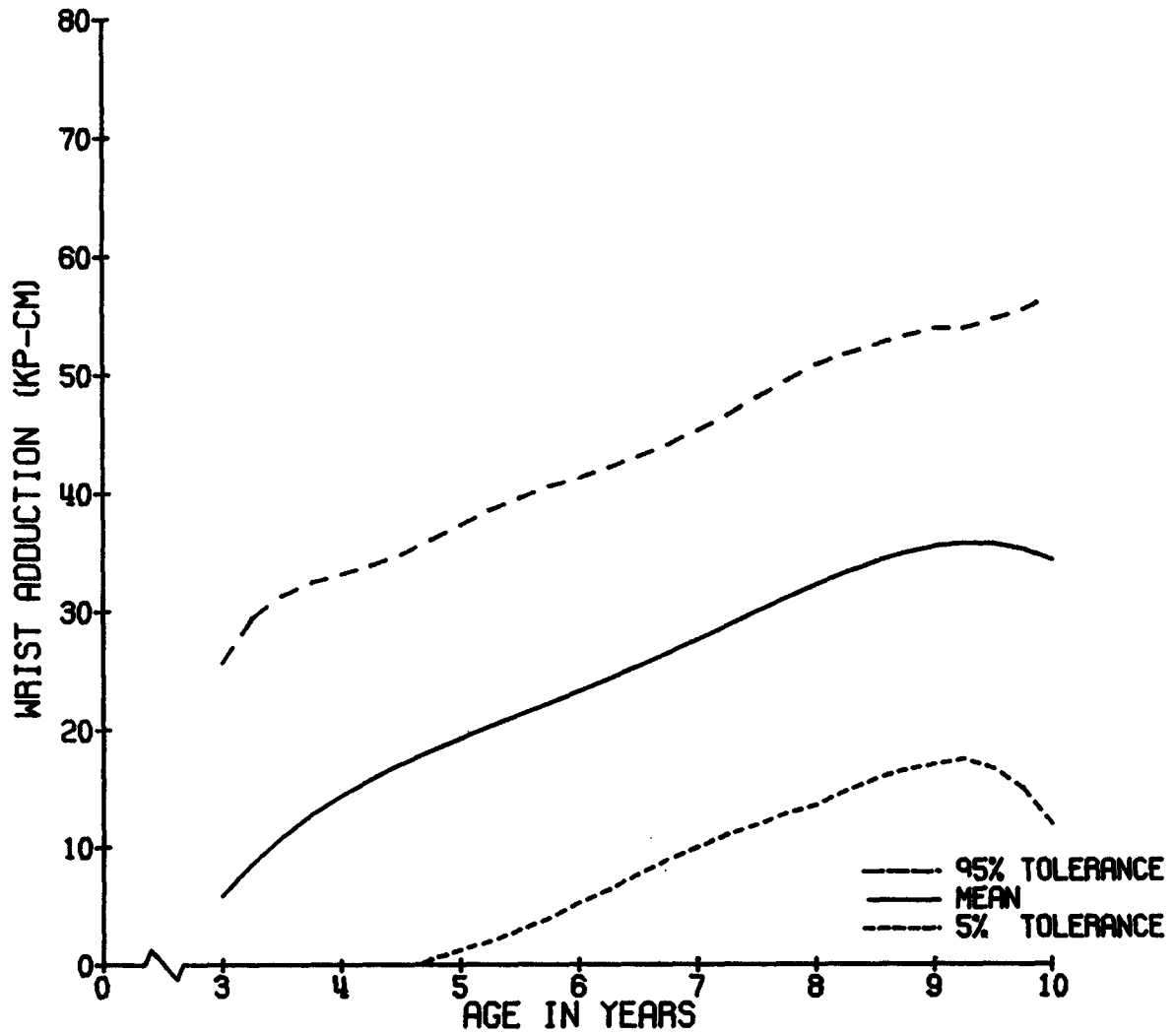

WRIST ADDUCTION, 3 DEG. (KP-CM)

MALES

AGE	N	MEAN	ST. DEV	MIN	10%	MEDIAN	90%	MAX
3	5	11.0	6.0	5.6	5.6	9.4	19.2	19.2
4	16	16.3	7.5	6.9	7.8	15.6	25.3	32.4
5	10	17.3	8.7	4.8	4.8	16.7	25.6	34.4
6	22	23.0	7.5	9.9	12.9	22.8	31.7	35.6
7	14	29.0	10.6	7.2	14.7	30.9	43.7	44.3
8	17	32.0	10.2	14.1	22.2	23.2	49.7	52.7
9	11	37.3	14.9	16.8	23.9	34.4	58.4	61.3
10	7	38.0	17.9	23.6	23.6	32.6	76.7	76.7

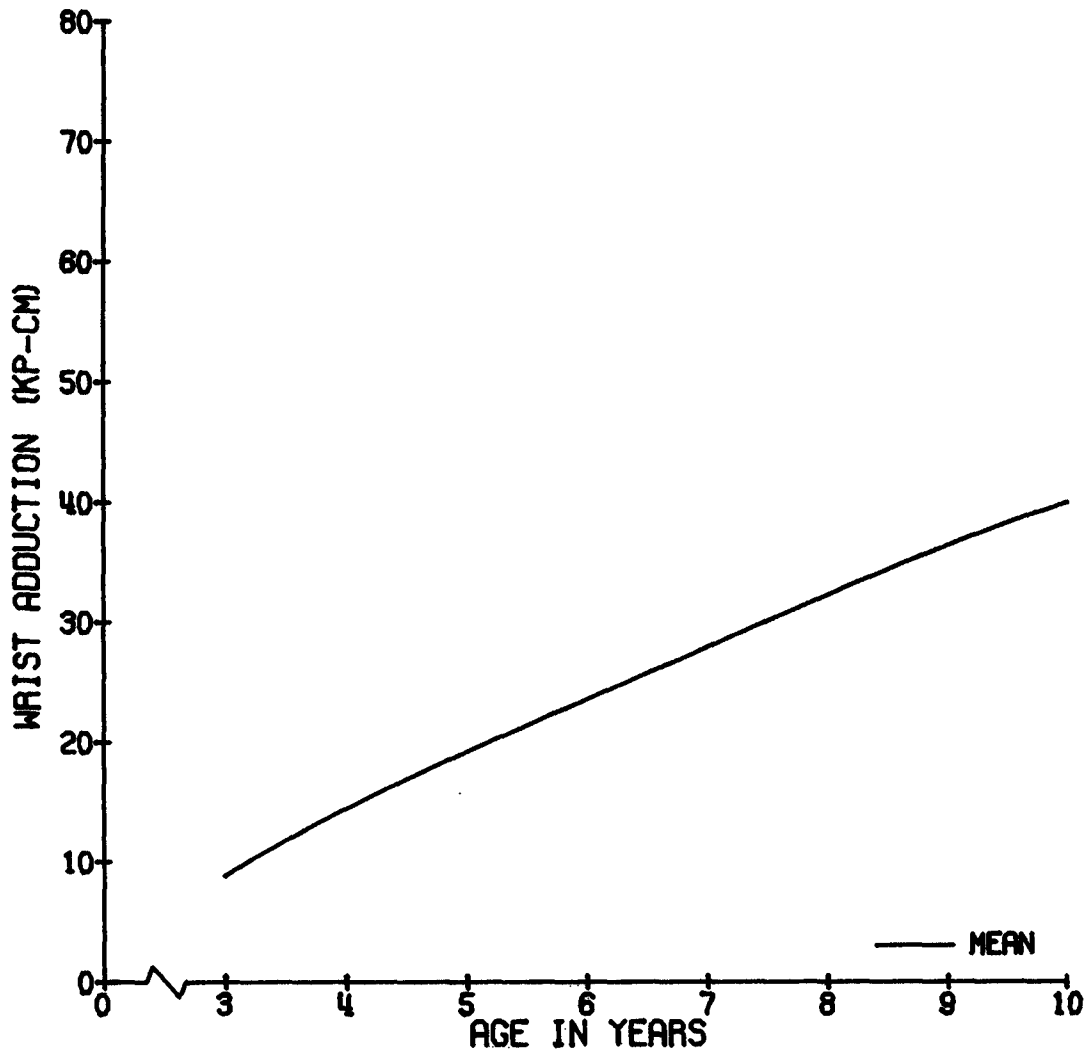

WRIST ADDUCTION, 0 DEG. (KP-CM)

FEMALES

AGE	N	MEAN	ST. DEV	MIN	10%	MEDIAN	90%	MAX
3	2	7.9	3.6	5.4	5.4	7.9	10.5	10.5
4	18	13.3	6.8	4.1	7.1	12.1	20.5	31.7
5	20	19.1	7.9	6.7	11.1	17.3	26.7	39.4
6	14	23.1	7.3	7.9	12.9	23.1	33.2	33.3
7	14	26.9	10.7	16.5	17.3	23.1	45.5	52.1
8	11	31.3	10.0	16.4	20.0	31.1	39.9	51.9
9	17	33.5	13.2	14.5	14.5	35.9	50.0	57.1
10	7	31.4	13.2	15.4	15.4	31.1	53.8	53.8

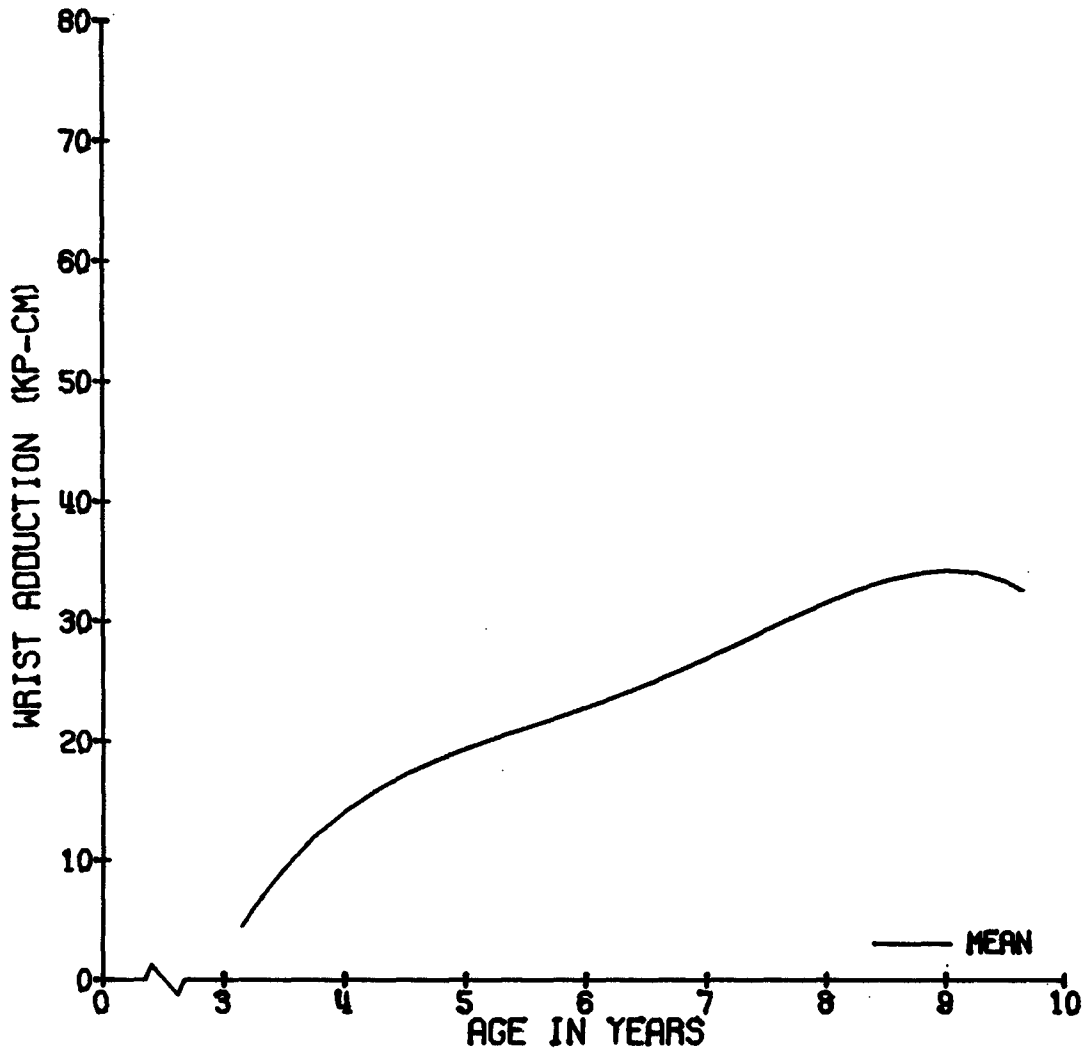

WRIST ABDUCTION

DESCRIPTION OF TEST: The hand is rotated laterally at the wrist joint (radiocarpal joint center) in the coronal plane.

TEST POSITION: The shoulder is abducted 5° , elbow flexed 90° , and wrist neutral at 0° . The right hand grasps a 2.5 cm diameter handle, the left forearm (distal to the humero-ulnar joint center) is unrestrained.

ANTHROPOMETRIC MEASUREMENTS: The carpal, radial, humeral, sacral, and thoracolumbar linkages are measured with an anthropometer.

ADJUSTMENT OF EQUIPMENT: The chair back fixture is set to the sacral plus thoracolumbar length, aligning the shoulder joint center with that of the chair. The chair arm fixtures are set to the humeral and radial plus carpal lengths, aligning the elbow joint center and center of grip with those of the chair. Thin rubber pads are placed under the arm as needed to maintain these alignments. The shoulder abduction angle is locked at 5° and elbow flexion at 90° . The distal edge of the wrist support is adjusted to align with the wrist joint center. The wrist and arm straps are then secured snugly around the arm and the chest strap around the chest and left upper arm. The subject's right hand is placed to grasp the handle on the chair. His left forearm is placed in his lap.

INSTRUCTIONS TO SUBJECT: The child pulls his hand up and his wrist down.

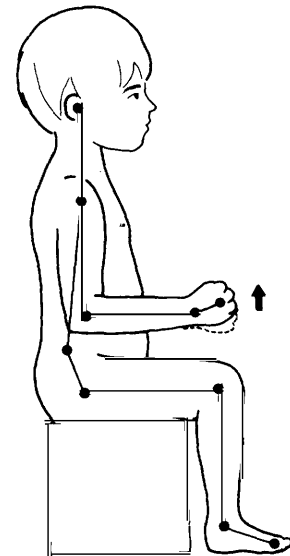
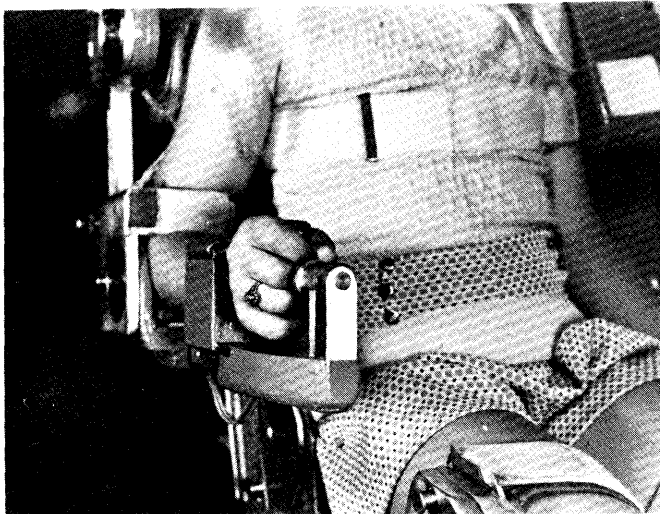

WRIST ABDUCTION, 0 DEG. (KP-CM)

COMBINED SEXES

AGE	N	MEAN	ST. DEV	MIN	10%	MEDIAN	90%	MAX
3	7	5.4	1.1	4.0	4.0	5.3	6.7	6.7
4	34	7.3	3.7	2.0	4.1	7.0	10.2	22.2
5	30	8.5	3.9	2.9	4.7	8.1	12.9	20.3
6	36	12.0	4.4	4.1	6.6	11.2	18.6	24.2
7	28	13.4	4.5	4.6	7.2	13.3	18.2	24.3
8	28	18.4	6.9	9.2	10.3	17.2	24.5	41.9
9	28	19.9	7.5	8.2	9.9	19.1	32.0	33.1
10	14	20.5	9.6	5.0	9.0	19.9	33.3	41.6

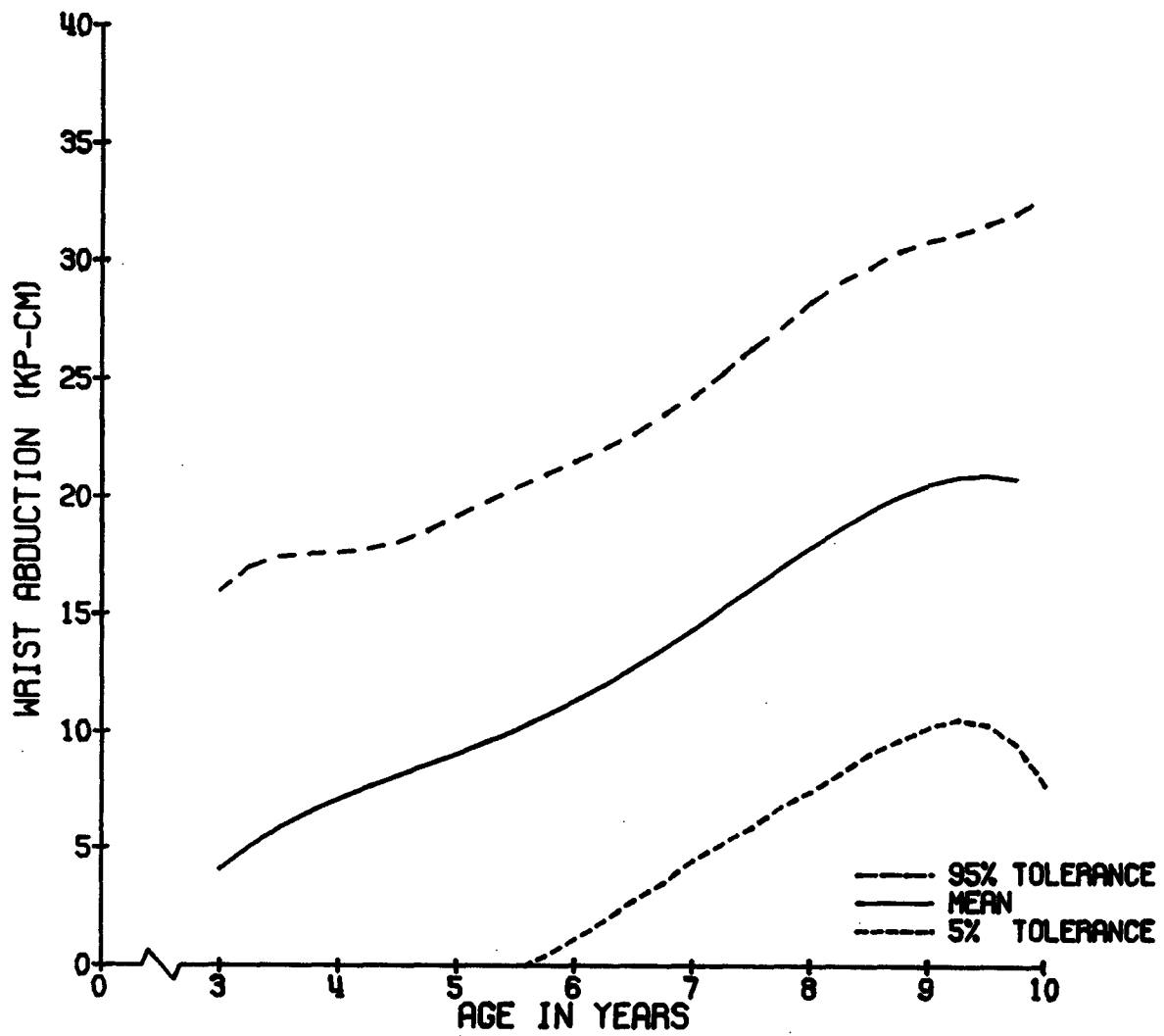

WRIST ABDUCTION, 0 DEG. (KP-CM)

MALES

AGE	N	MEAN	ST. DEV	MIN	10%	MEDIAN	90%	MAX
3	5	5.6	1.1	4.0	4.0	5.7	6.7	6.7
4	16	7.3	3.0	2.0	3.4	7.7	10.4	15.5
5	9	8.8	5.0	3.8	3.8	8.1	20.3	20.3
6	22	11.0	3.3	4.1	7.2	11.1	15.3	18.6
7	14	12.9	4.6	4.6	7.2	12.6	17.9	22.0
8	17	19.7	7.7	9.5	12.0	17.4	29.1	41.9
9	11	22.1	7.6	10.6	14.3	22.1	32.0	33.1
10	7	23.9	11.8	5.0	5.0	22.3	41.6	41.6

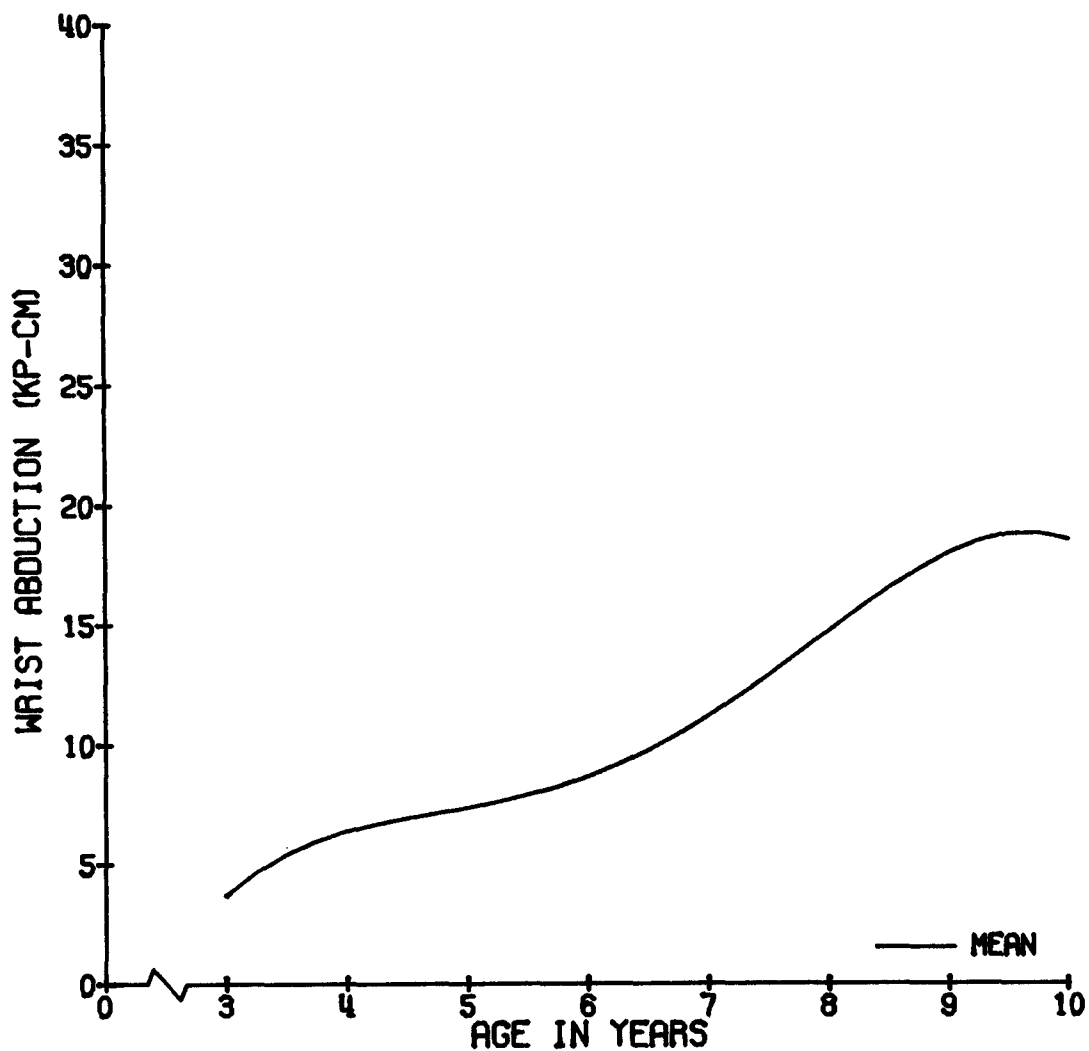

WRIST ABDUCTION, 0 DEG. (KP-CM)

FEMALES

AGE	N	MEAN	ST. DEV	MIN	10%	MEDIAN	90%	MAX
3	2	4.7	0.8	4.1	4.1	4.7	5.3	5.3
4	13	6.9	4.2	2.7	4.1	5.8	10.2	22.2
5	21	8.4	3.4	2.9	5.4	8.1	12.9	16.9
6	14	13.5	5.6	5.9	6.6	12.8	21.8	24.2
7	14	13.8	4.6	5.4	8.6	13.4	18.2	24.3
8	11	16.5	5.2	9.2	10.3	16.3	22.6	24.4
9	17	18.5	7.3	8.2	8.3	17.6	27.7	32.9
10	7	17.1	5.8	9.0	9.0	15.5	24.1	24.1

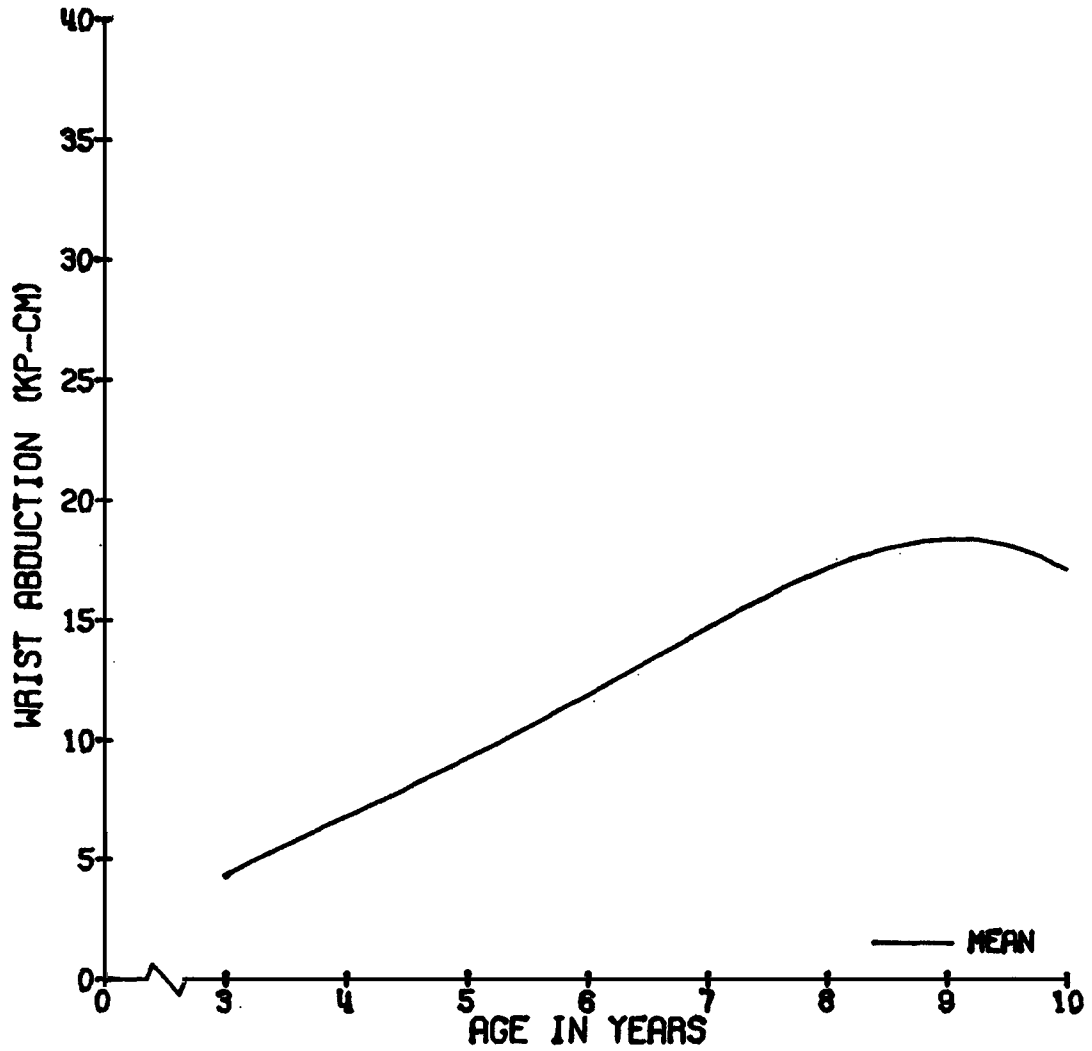

WRIST PRONATION

DESCRIPTION OF TEST: The radius is rotated across the ulna, moving the thumb medially and turning the palm from an anterior to posterior position.

TEST POSITION: The shoulder is abducted 5° , elbow flexed 90° , and wrist neutral at 0° . The right hand grasps a 2.5 cm diameter handle, the left forearm (distal to the humero-ulnar joint center) is unrestrained.

ANTHROPOMETRIC MEASUREMENTS: The carpal, radial, humeral, sacral, and thoracolumbar linkages are measured with an anthropometer.

ADJUSTMENT OF EQUIPMENT: The chair back fixture is set to the sacral plus thoracolumbar length, aligning the shoulder joint center with that of the chair. The chair arm fixtures are set to the humeral and radial plus carpal lengths, aligning the elbow joint center and center of grip with those of the chair. Thin rubber pads are placed under the arm as needed to maintain these alignments. The shoulder abduction angle is locked at 5° and elbow flexion at 90° . The distal edge of the wrist support is adjusted to align with the wrist joint center. The wrist and arm straps are then secured snugly around the arm and the chest strap around the chest and left upper arm. The subject's right hand is placed to grasp the handle on the chair. His left forearm is placed in his lap.

INSTRUCTIONS TO SUBJECT: The child twists the top of his hand to his left and the bottom of his hand to his right.

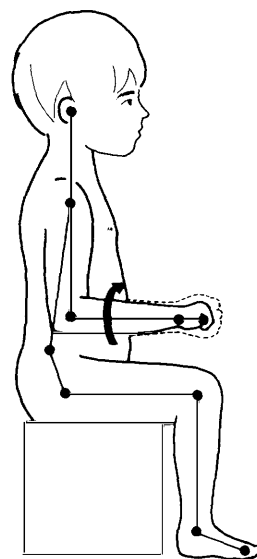
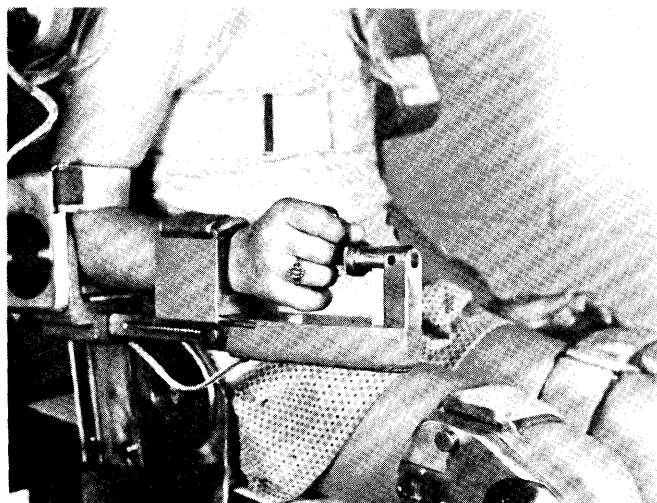

WRIST PRONATION, 0 DEG. (KP-CM)

COMBINED SEXES

AGE	N	MEAN	ST. DEV	MIN	10%	MEDIAN	90%	MAX
3	6	6.4	2.7	3.7	3.7	5.7	9.7	9.7
4	34	7.2	2.3	3.2	4.7	6.7	10.2	12.2
5	30	8.6	2.6	4.6	4.9	8.3	11.8	15.9
6	36	13.1	3.0	8.2	9.0	12.9	16.5	20.5
7	28	14.1	4.2	6.9	9.4	12.9	20.1	22.9
8	27	19.7	5.0	12.4	13.5	19.9	29.1	30.4
9	29	20.7	7.0	9.4	13.0	20.1	31.1	43.8
10	15	20.7	7.2	9.5	9.5	18.8	31.2	31.4

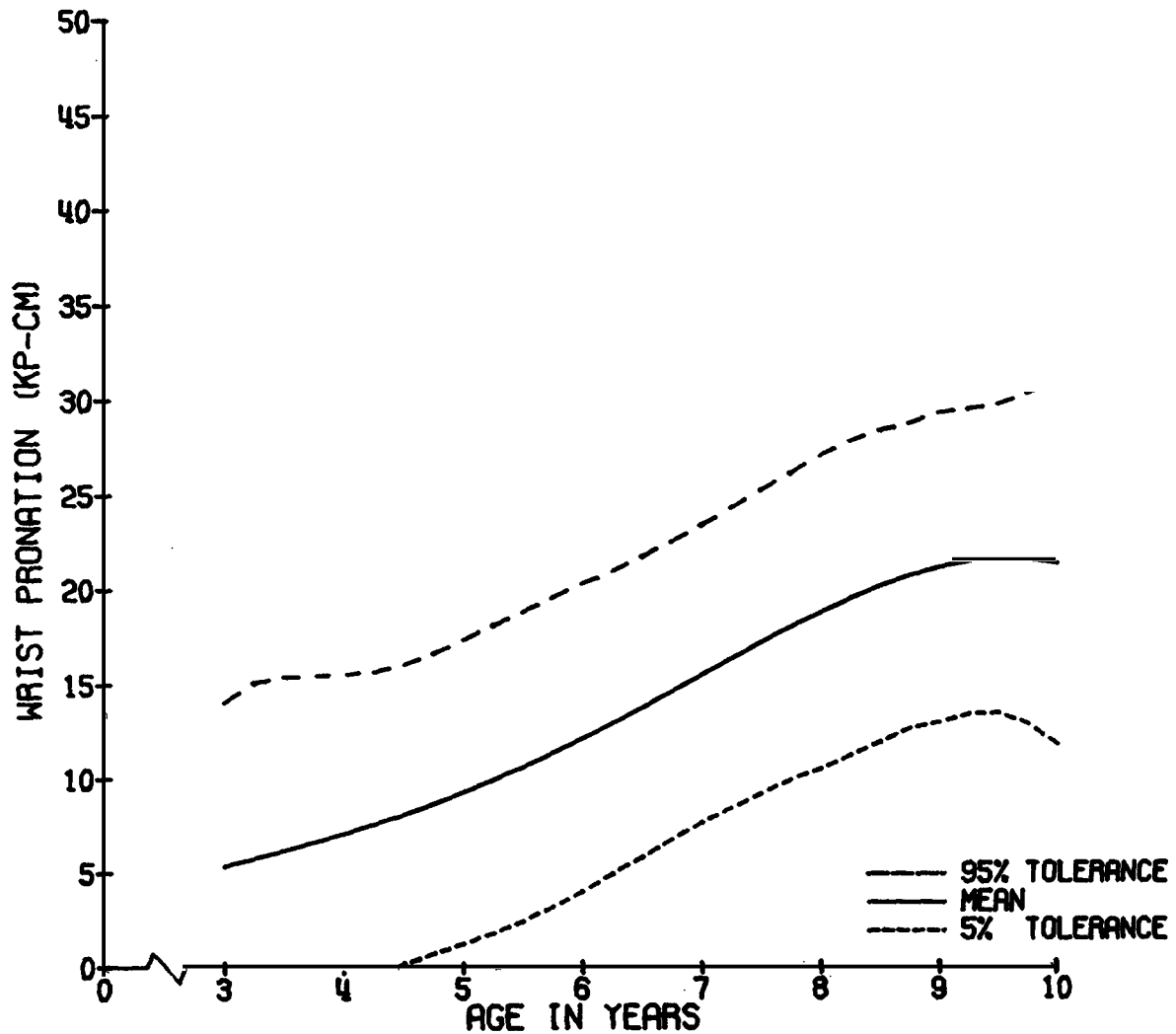

WRIST PRONATION, 0 DEG. (KP-CM)

MALES

AGE	N	MEAN	ST. DEV	MIN	10%	MEDIAN	90%	MAX
3	4	6.2	2.8	3.7	3.7	5.7	9.7	9.7
4	17	7.3	2.6	3.2	3.9	8.6	11.4	12.2
5	9	10.2	3.5	5.0	5.0	8.7	15.9	15.9
6	22	13.4	3.3	8.2	9.0	13.2	18.2	20.5
7	13	15.3	4.9	8.5	9.4	14.9	22.2	22.9
8	17	20.5	5.4	12.4	15.0	18.9	30.1	30.4
9	12	25.5	7.5	17.6	19.4	23.0	33.2	43.8
10	7	23.9	6.0	17.3	17.3	25.1	31.4	31.4

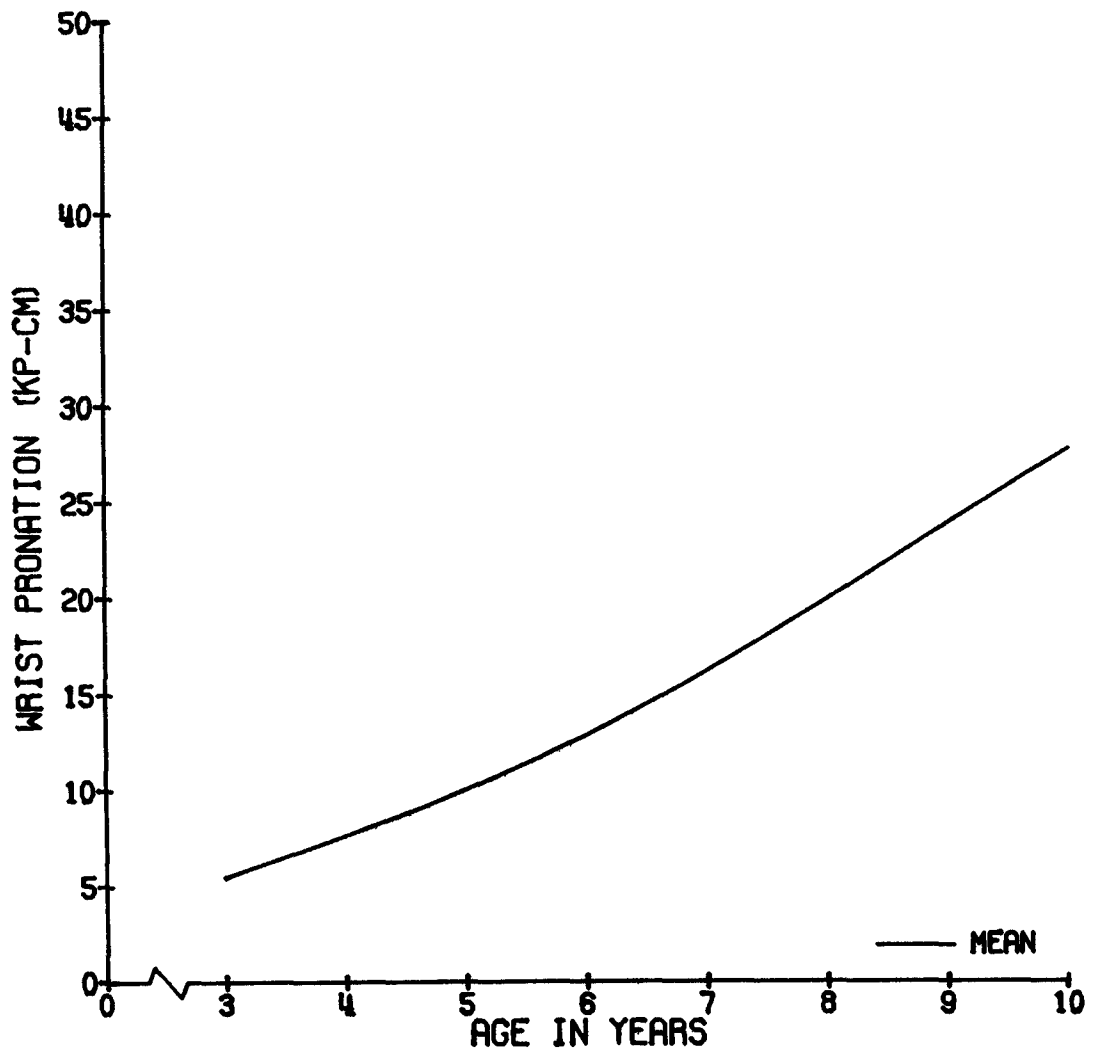

WRIST PRONATION, 9 DEG. (KP-CM)

FEMALES

AGE	N	MEAN	ST. DEV	MIN	10%	MEDIAN	90%	MAX
3	2	6.7	3.5	4.3	4.3	6.7	9.2	9.2
4	17	6.5	1.8	4.6	4.7	6.0	8.6	10.5
5	21	8.1	2.0	4.6	4.9	8.2	10.8	11.8
6	14	12.6	2.5	9.0	9.2	12.0	16.2	16.5
7	15	13.1	3.2	6.9	9.8	12.3	18.4	18.8
8	10	18.4	4.3	12.6	12.6	18.4	23.6	23.7
9	17	17.3	4.2	9.4	12.8	18.8	22.0	23.3
10	8	17.9	7.2	9.5	9.5	16.9	30.7	30.7

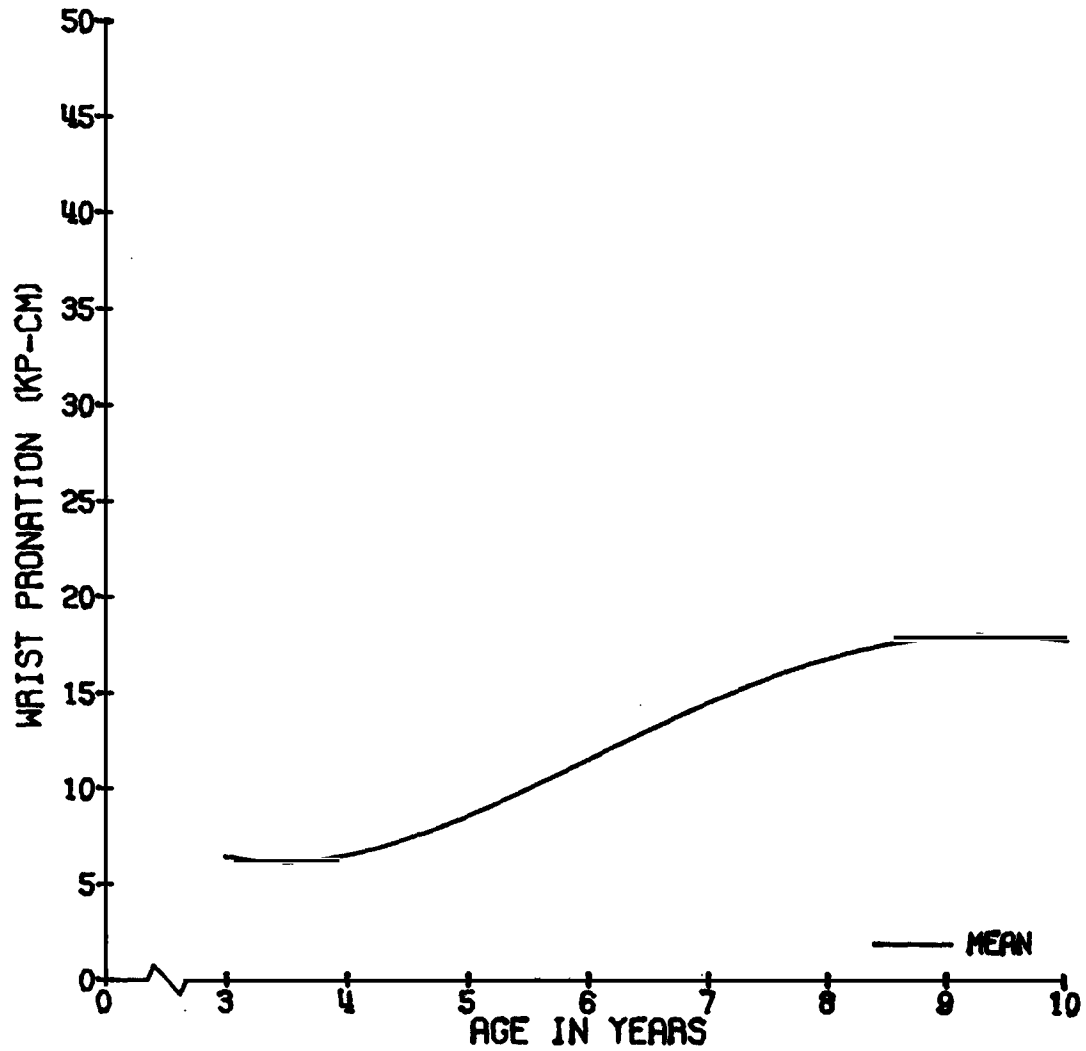

WRIST SUPINATION

DESCRIPTION OF TEST: The radius is rotated across the ulna, moving the thumb laterally and turning the palm from a posterior to anterior position.

TEST POSITION: The shoulder is abducted 5° , elbow flexed 90° , and wrist neutral at 0° . The right hand grasps a 2.5 cm diameter handle, the left forearm (distal to the humero-ulnar joint center) is unrestrained.

ANTHROPOMETRIC MEASUREMENTS: The carpal, radial, humeral, sacral, and thoracolumbar linkages are measured with an anthropometer.

ADJUSTMENT OF EQUIPMENT: The chair back fixture is set to the sacral plus thoracolumbar length, aligning the shoulder joint center with that of the chair. The chair arm fixtures are set to the humeral and radial plus carpal lengths, aligning the elbow joint center and center of grip with those of the chair. Thin rubber pads are placed under the arm as needed to maintain these alignments. The shoulder abduction angle is locked at 5° and elbow flexion at 90° . The distal edge of the wrist support is adjusted to align with the wrist joint center. The wrist and arm straps are then secured snugly around the arm and the chest strap around the chest and left upper arm. The subject's right hand is placed to grasp the handle on the chair. His left forearm is placed in his lap.

INSTRUCTIONS TO SUBJECT: The child twists the top of his hand to his right and the bottom of his hand to his left.

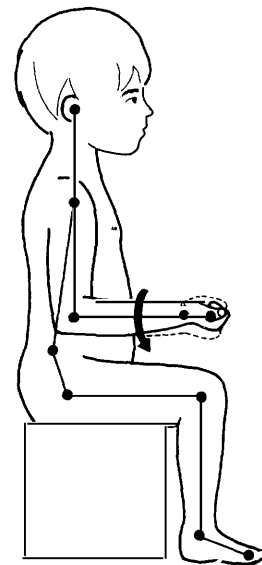
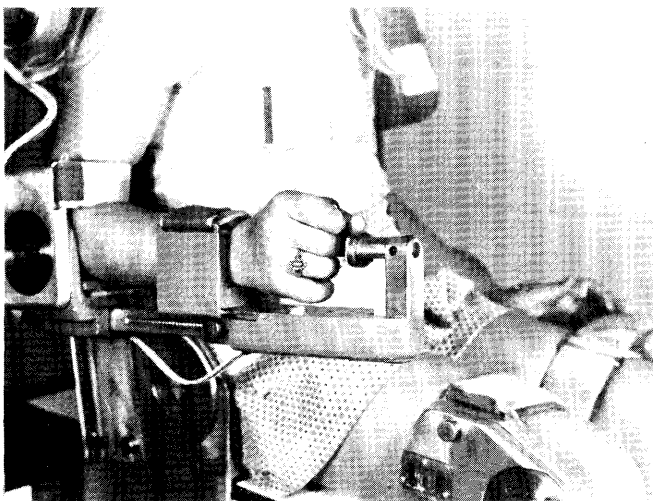

WRIST SUPINATION, 0 DEG. (KP-CM)

COMBINED SEXES

AGE	N	MEAN	ST. DEV	MIN	10%	MEDIAN	90%	MAX
3	7	5.4	2.2	2.8	2.8	4.4	8.7	8.7
4	33	8.2	3.4	3.4	4.8	7.6	12.3	18.6
5	30	9.3	3.7	4.2	4.4	8.6	13.0	21.2
6	36	13.5	3.5	5.6	9.3	13.2	17.2	23.2
7	28	16.2	4.4	6.6	11.1	15.9	21.3	26.0
8	27	21.5	5.9	13.4	14.5	19.9	30.4	32.3
9	29	26.5	9.1	10.1	13.7	26.3	39.0	46.1
10	15	25.6	10.1	13.4	13.8	24.0	40.7	40.9

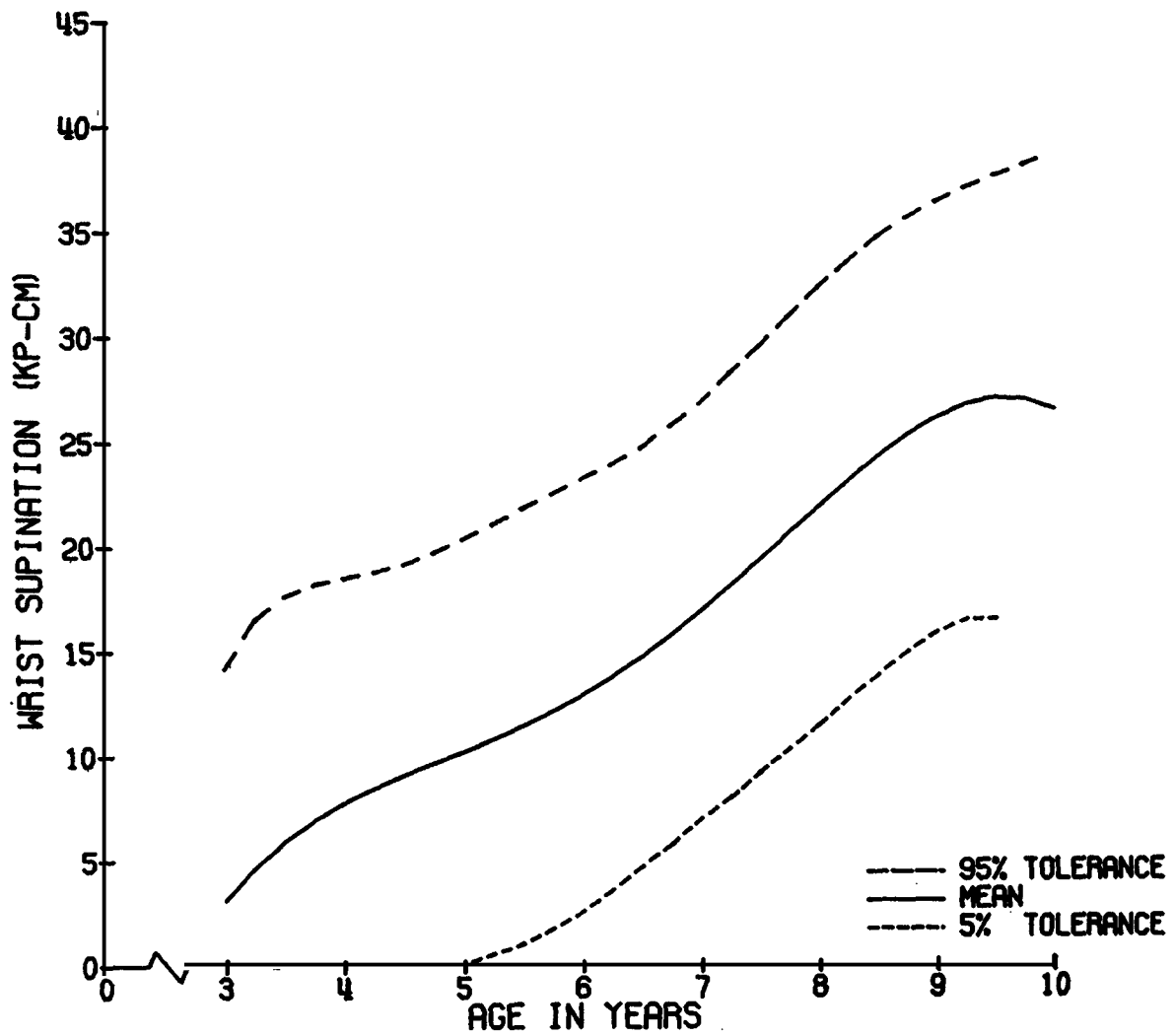

WRIST SUPINATION, 0 DEG. (KP-CM)

MALES

AGE	N	MEAN	ST. DEV	MIN	10%	MEDIAN	90%	MAX
3	5	5.3	2.5	2.8	2.8	4.4	8.7	8.7
4	17	8.6	3.6	3.4	5.3	8.2	12.3	18.6
5	10	10.4	5.7	4.2	4.2	9.8	16.7	21.2
6	22	13.9	3.6	5.6	9.3	15.2	17.2	18.4
7	13	17.1	5.3	8.8	11.1	16.1	25.7	26.0
8	17	22.0	5.5	14.5	16.6	19.9	30.4	32.0
9	12	30.3	3.9	17.4	19.1	28.7	41.5	46.1
10	7	32.2	10.9	13.8	13.8	38.6	40.9	40.9

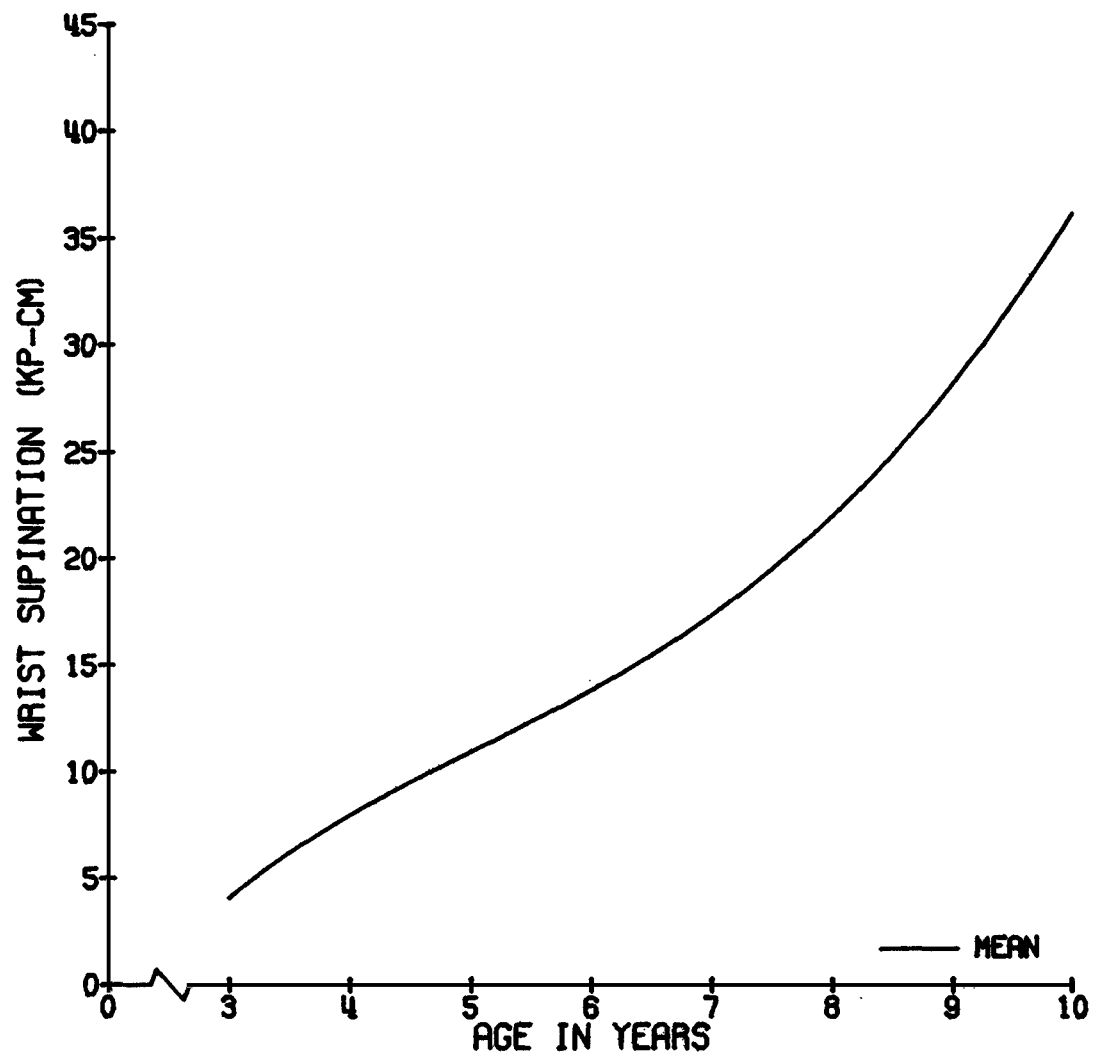

WRIST SUPINATION, 9 DEG. (KP-CM)

FEMALES

AGE	N	MEAN	ST. DEV	MIN	10%	MEDIAN	90%	MAX
3	2	5.6	1.8	4.3	4.3	5.6	6.9	6.9
4	16	7.9	3.4	3.8	4.4	7.2	13.7	15.5
5	22	8.8	2.2	5.0	5.8	8.3	11.1	13.0
6	14	12.9	3.4	8.0	10.5	12.7	14.4	23.2
7	15	15.5	3.5	6.6	13.1	15.1	21.0	21.3
8	10	20.6	6.6	13.4	13.4	19.4	28.7	32.3
9	17	23.3	8.5	10.1	13.5	25.0	37.8	39.0
10	8	19.9	4.5	13.4	13.4	19.7	25.4	25.4

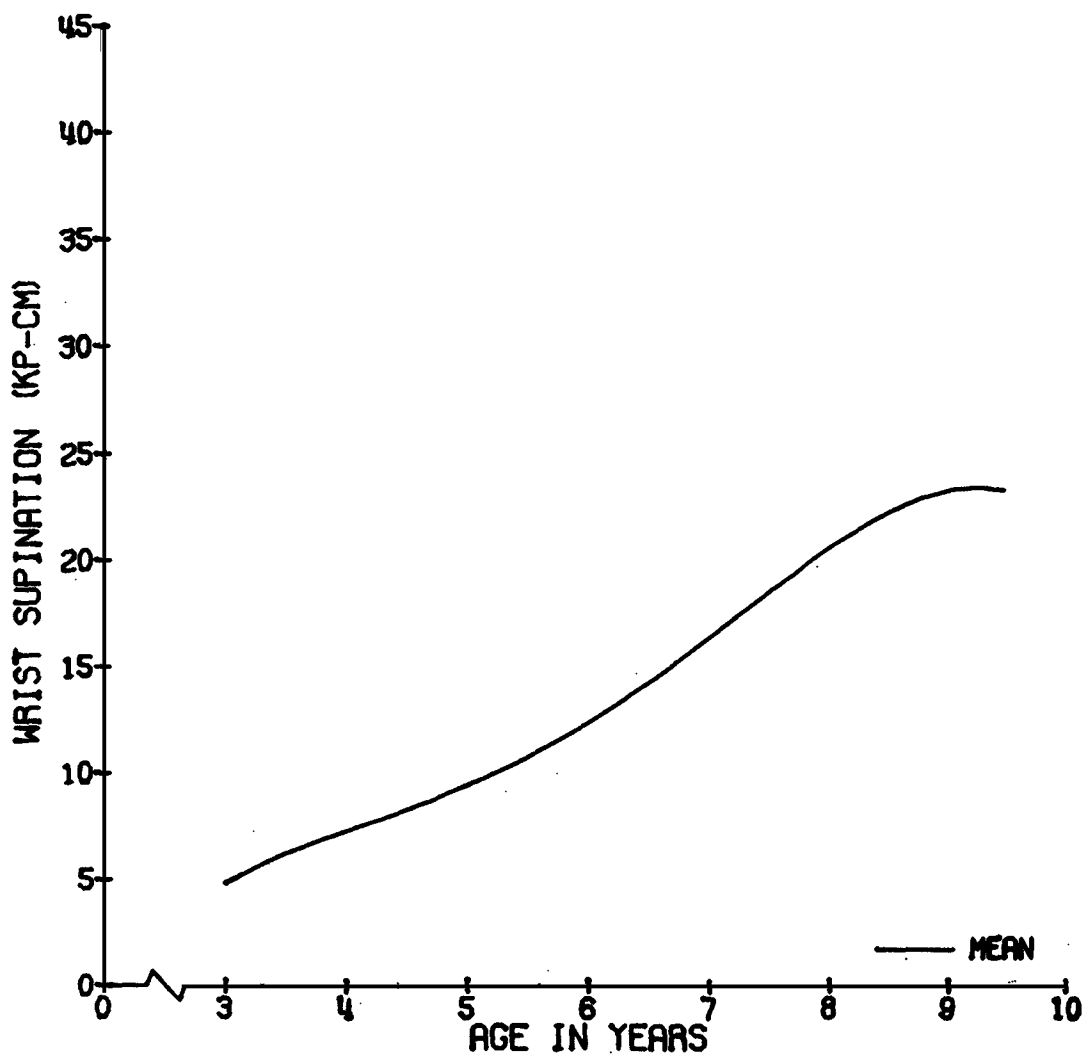

ELBOW FLEXION

DESCRIPTION OF TEST: The radius and ulna are rotated anteriorly at the elbow joint (humero-ulnar joint center) in the sagittal plane.

TEST POSITION: The shoulder is abducted 5° , elbow flexed 90° , and wrist neutral at 0° . The right hand grasps a 2.5 cm diameter handle, the left forearm (distal to the humero-ulnar joint center) is unrestrained.

ANTHROPOMETRIC MEASUREMENTS: The carpal, radial, humeral, sacral, and thoracolumbar linkages are measured with an anthropometer.

ADJUSTMENT OF EQUIPMENT: The chair back fixture is set to the sacral plus thoracolumbar length, aligning the shoulder joint center with that of the chair. The chair arm fixtures are set to the humeral and radial plus carpal lengths, aligning the elbow joint center and center of grip with those of the chair. Thin rubber pads are placed under the arm as needed to maintain these alignments. The shoulder abduction angle is locked at 5° and elbow flexion at 90° . The distal edge of the wrist support is adjusted to align with the wrist joint center. The wrist and arm straps are then secured snugly around the arm and the chest strap around the chest and left upper arm. The subject's right hand is placed to grasp the handle on the chair. His left forearm is placed in his lap.

INSTRUCTIONS TO SUBJECT: The child pulls his wrist (and hand) up and his elbow down.

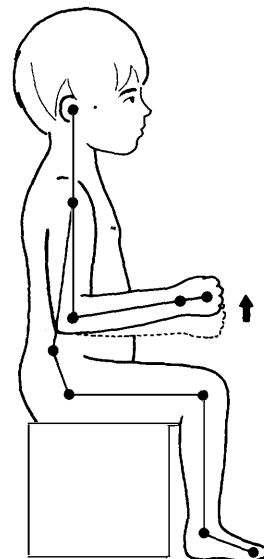

ELBOW FLEXION, 90 DEG. (KP-CM)

COMBINED SEXES

AGE	N	MEAN	ST. DEV	MIN	10%	MEDIAN	90%	MAX
3	12	61.8	15.9	39.5	42.8	59.5	82.4	95.1
4	74	74.5	23.7	33.8	46.8	72.5	102.5	145.5
5	81	95.0	32.5	43.3	60.9	93.0	133.1	211.8
6	70	121.5	30.4	58.2	80.3	121.9	159.0	202.8
7	78	172.0	42.3	33.0	127.8	165.5	229.9	272.7
8	71	215.5	51.6	109.8	155.2	209.7	289.7	325.3
9	81	229.1	63.7	82.6	145.7	233.2	307.3	414.4
10	28	240.8	61.5	137.9	157.5	248.3	331.7	377.9

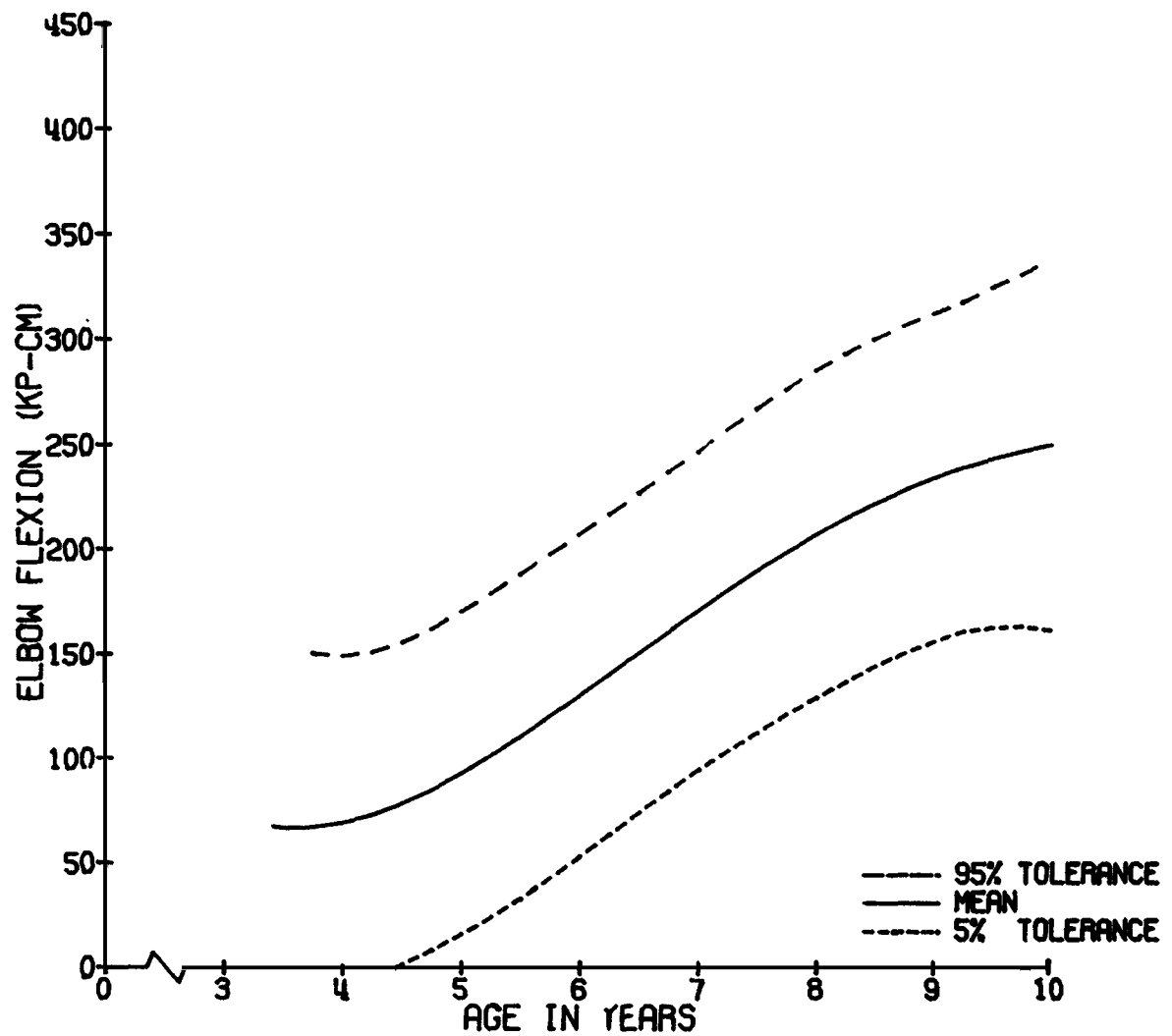

ELBOW FLEXION, 90 DEG. (KP-CM)

MALES

AGE	N	MEAN	ST. DEV	MIN	10%	MEDIAN	90%	MAX
3	8	65.4	15.4	51.5	51.5	59.5	95.1	95.1
4	32	81.3	26.6	33.8	48.3	85.3	105.8	145.5
5	32	102.7	42.0	60.2	61.0	89.1	178.4	211.8
6	38	125.9	31.2	58.2	83.2	123.9	166.7	202.8
7	36	163.2	46.5	33.0	116.8	159.2	226.3	272.7
8	37	213.2	45.3	151.9	162.9	203.0	294.0	321.5
9	38	261.7	58.9	156.3	189.1	256.4	313.1	414.4
10	16	257.1	67.5	137.9	169.8	255.1	337.9	377.9

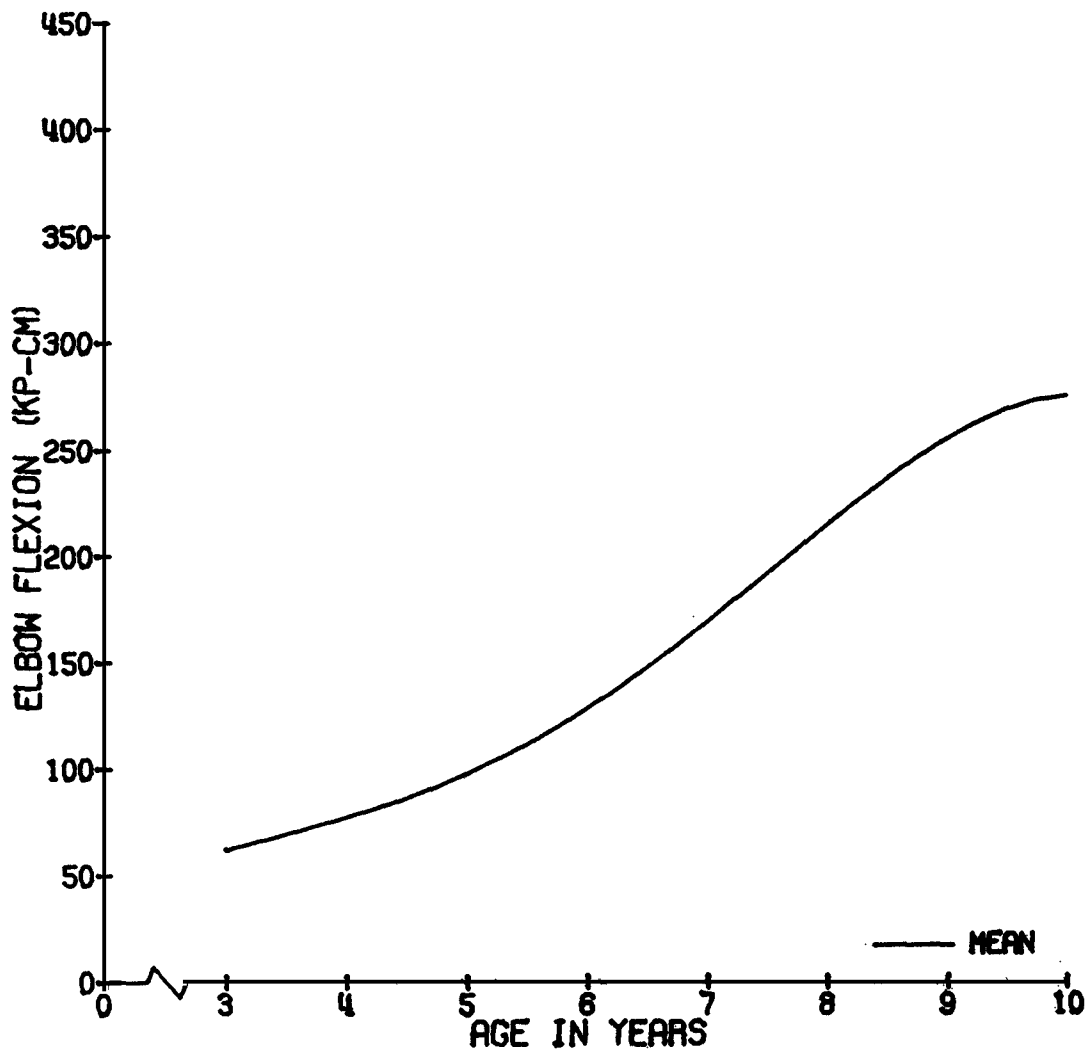

ELBOW FLEXION, 90 DEG. (KP-CM)

FEMALES

AGE	N	MEAN	ST. DEV	MIN	10%	MEDIAN	90%	MAX
3	4	54.5	16.5	39.5	39.5	52.0	74.7	74.7
4	42	69.3	20.1	35.6	46.8	62.4	97.1	117.3
5	49	90.0	23.6	43.3	55.2	93.3	123.2	134.2
6	32	116.2	29.0	63.1	76.0	116.7	149.8	176.8
7	42	175.3	38.6	109.3	131.2	168.9	230.2	243.5
8	34	212.6	58.3	109.8	141.3	219.9	289.7	325.3
9	43	200.3	53.6	82.6	127.9	205.0	263.4	307.3
10	12	219.0	46.7	141.2	157.5	225.9	269.3	276.0

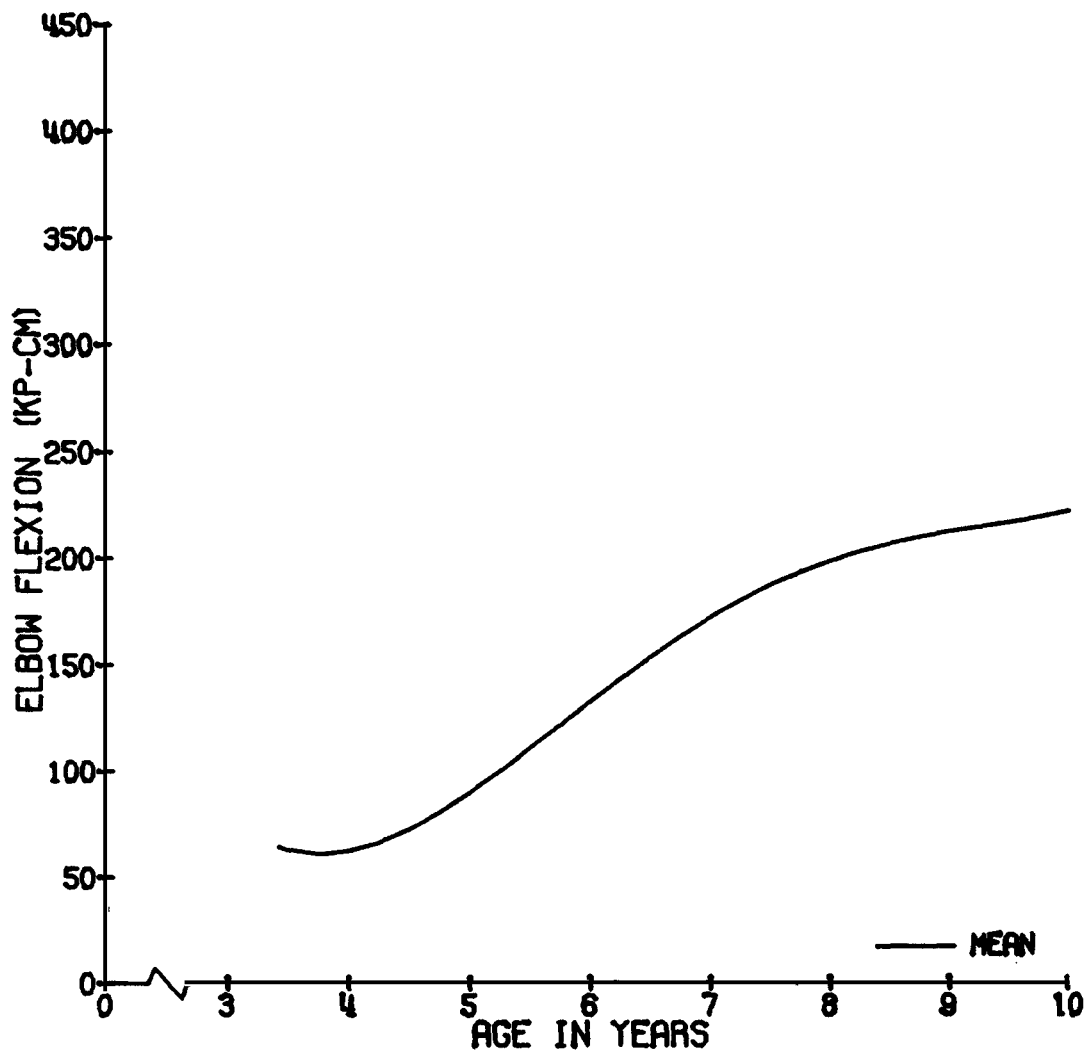

ELBOW EXTENSION

DESCRIPTION OF TEST: The radius and ulna are rotated posteriorly at the elbow joint (humero-ulnar joint center) in the sagittal plane.

TEST POSITION: The shoulder is abducted 5° , elbow flexed 90° , and wrist neutral at 0° . The right hand grasps a 2.5 cm diameter handle, the left forearm (distal to the humero-ulnar joint center) is unrestrained.

ANTHROPOMETRIC MEASUREMENTS: The carpal, radial, humeral, sacral and thoracolumbar linkages are measured with an anthropometer.

ADJUSTMENT OF EQUIPMENT: The chair back fixture is set to the sacral plus thoracolumbar length, aligning the shoulder joint center with that of the chair. The chair arm fixtures are set to the humeral and radial plus carpal lengths, aligning the elbow joint center and center of grip with those of the chair. Thin rubber pads are placed under the arm as needed to maintain these alignments. The shoulder abduction angle is locked at 5° and elbow flexion at 90° . The distal edge of the wrist support is adjusted to align with the wrist joint center. The wrist and arm straps are then secured snugly around the arm and the chest strap around the chest and left upper arm. The subject's right hand is placed to grasp the handle on the chair. His left forearm is placed in his lap.

INSTRUCTIONS TO SUBJECT: The child pushes his wrist (and hand) down.

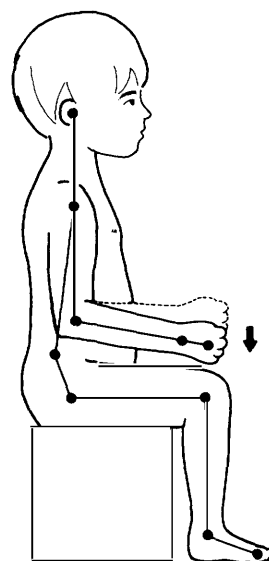

ELBOW EXTENSION, 90 DEG. (KP-CM)

COMBINED SEXES

AGE	N	MEAN	ST. DEV	MIN	10%	MEDIAN	90%	MAX
3	12	62.3	11.3	37.2	47.5	65.7	74.6	75.4
4	74	73.3	26.4	19.7	42.5	72.4	108.3	137.4
5	81	91.8	29.0	43.3	56.2	86.6	132.1	167.3
6	70	105.4	38.0	45.4	60.3	94.6	157.0	220.1
7	79	135.8	44.9	19.7	89.3	133.7	192.2	333.3
8	71	164.3	44.5	71.5	110.5	168.8	211.0	298.3
9	81	170.8	53.7	30.6	105.0	165.7	234.6	312.5
10	28	162.6	45.5	80.0	126.7	149.6	229.4	276.9

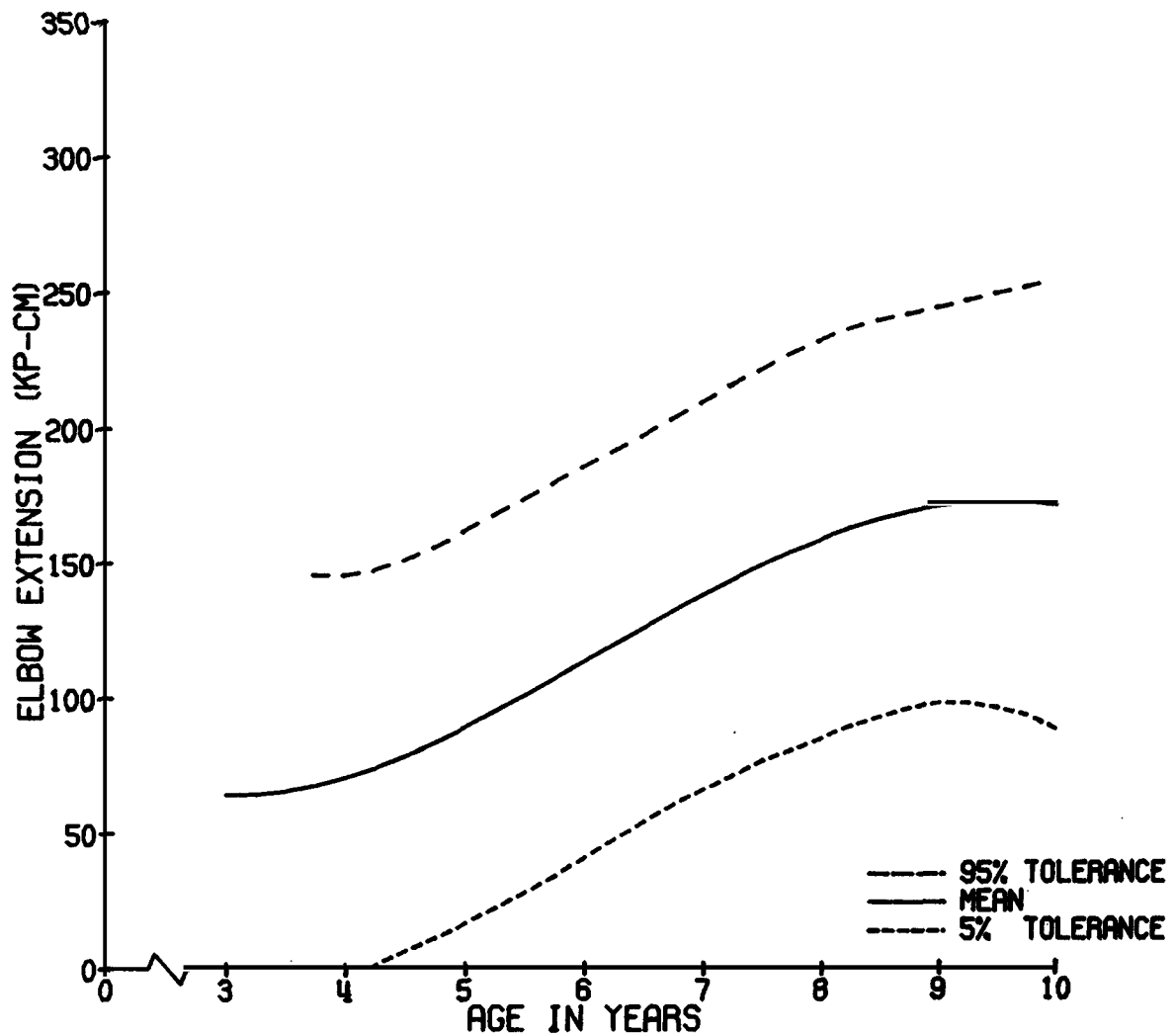

ELBOW EXTENSION, 90 DEG. (KP-CM)

MALES

AGE	N	MEAN	ST. DEV	MIN	10%	MEDIAN	90%	MAX
3	8	64.9	9.2	47.5	47.5	65.7	74.6	74.6
4	32	76.0	26.7	29.3	47.9	74.8	109.4	137.4
5	32	101.7	31.7	46.7	60.7	98.4	143.4	164.4
6	38	107.8	39.4	45.4	59.3	102.0	164.8	220.1
7	36	145.7	51.7	19.7	90.4	143.4	192.2	333.3
8	37	174.3	46.5	100.5	113.1	177.5	239.8	298.3
9	38	194.1	51.5	105.2	138.1	183.8	270.1	312.5
10	16	169.6	47.3	90.6	126.7	163.9	229.4	276.9

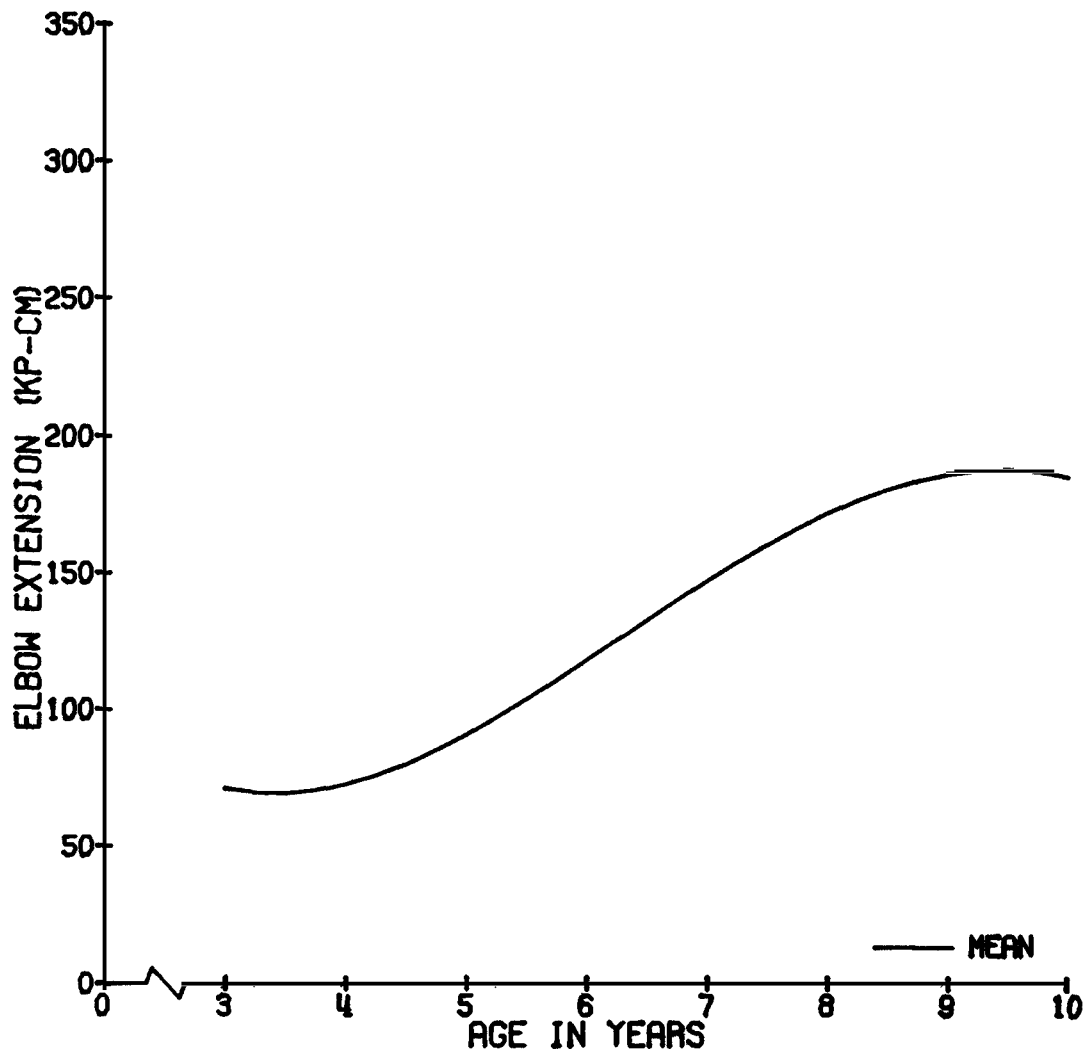

ELBOW EXTENSION, 90 DEG. (KP-CM)

FEMALES

AGE	N	MEAN	ST. DEV	MIN	10%	MEDIAN	90%	MAX
3	4	58.6	16.7	37.2	37.2	60.9	75.4	75.4
4	42	72.1	26.4	19.7	42.5	71.2	105.2	125.3
5	49	85.4	25.3	43.3	53.8	80.3	118.9	167.3
6	32	102.6	36.8	48.8	64.1	93.3	156.1	189.1
7	43	128.1	37.1	66.6	89.3	128.3	170.6	233.5
8	34	152.8	39.7	71.5	88.3	156.7	200.9	233.1
9	43	150.1	47.2	30.6	88.8	144.1	203.9	265.4
10	12	153.3	43.3	80.0	126.7	146.3	181.9	264.3

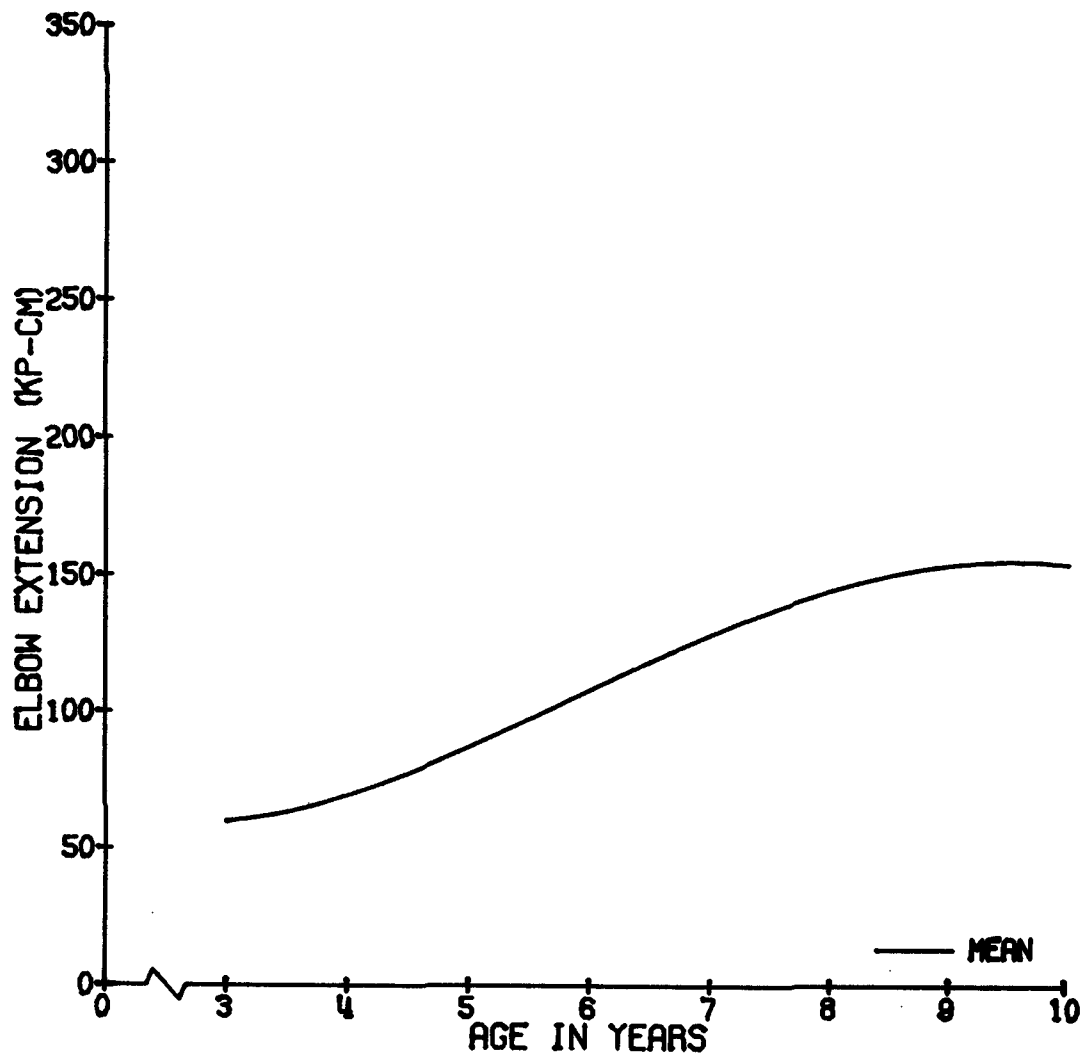

SHOULDER FLEXION

DESCRIPTION OF TEST: The humerus is rotated anteriorly at the shoulder joint (glenohumeral joint center) in the sagittal plane.

TEST POSITION: The shoulder is abducted 5° , elbow flexed 90° , and wrist neutral at 0° . The right hand grasps a 2.5 cm diameter handle, the left forearm (distal to the humero-ulnar joint center) is unrestrained.

ANTHROPOMETRIC MEASUREMENTS: The carpal, radial, humeral, sacral, and thoracolumbar linkages are measured with an anthropometer.

ADJUSTMENT OF EQUIPMENT: The chair back fixture is set to the sacral plus thoracolumbar length, aligning the shoulder joint center with that of the chair. The chair arm fixtures are set to the humeral and radial plus carpal lengths, aligning the elbow joint center and center of grip with those of the chair. Thin rubber pads are placed under the arm as needed to maintain these alignments. The shoulder abduction angle is locked at 5° and the elbow flexion at 90° . The distal edge of the wrist support is adjusted to align with the wrist joint center. The wrist and arm straps are then secured snugly around the arm and the chest strap around the chest and left upper arm. The subject's right hand is placed to grasp the handle on the chair. His left forearm is placed in his lap.

INSTRUCTIONS TO SUBJECT: The child pushes his elbow (and hand) forward.

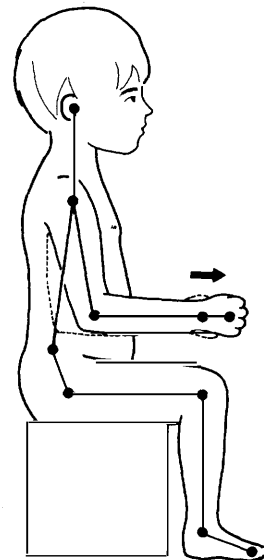

SHOULDER FLEXION, 0 DEG. (KP-CM)

COMBINED SEXES

AGE	N	MEAN	ST. DEV	MIN	10%	MEDIAN	90%	MAX
3	16	43.7	9.4	23.9	23.9	44.0	51.4	58.1
4	73	57.7	18.7	13.8	31.6	58.9	78.7	101.5
5	79	69.4	20.5	30.1	44.0	64.1	98.7	130.9
6	70	82.3	24.5	34.7	51.1	78.2	118.0	136.2
7	78	101.1	22.9	59.4	70.0	97.9	132.9	156.7
8	71	128.3	31.3	60.0	92.0	124.7	169.6	196.2
9	31	131.1	37.0	65.0	87.9	129.7	170.6	276.9
10	28	146.2	43.2	66.1	99.6	138.7	220.9	232.4

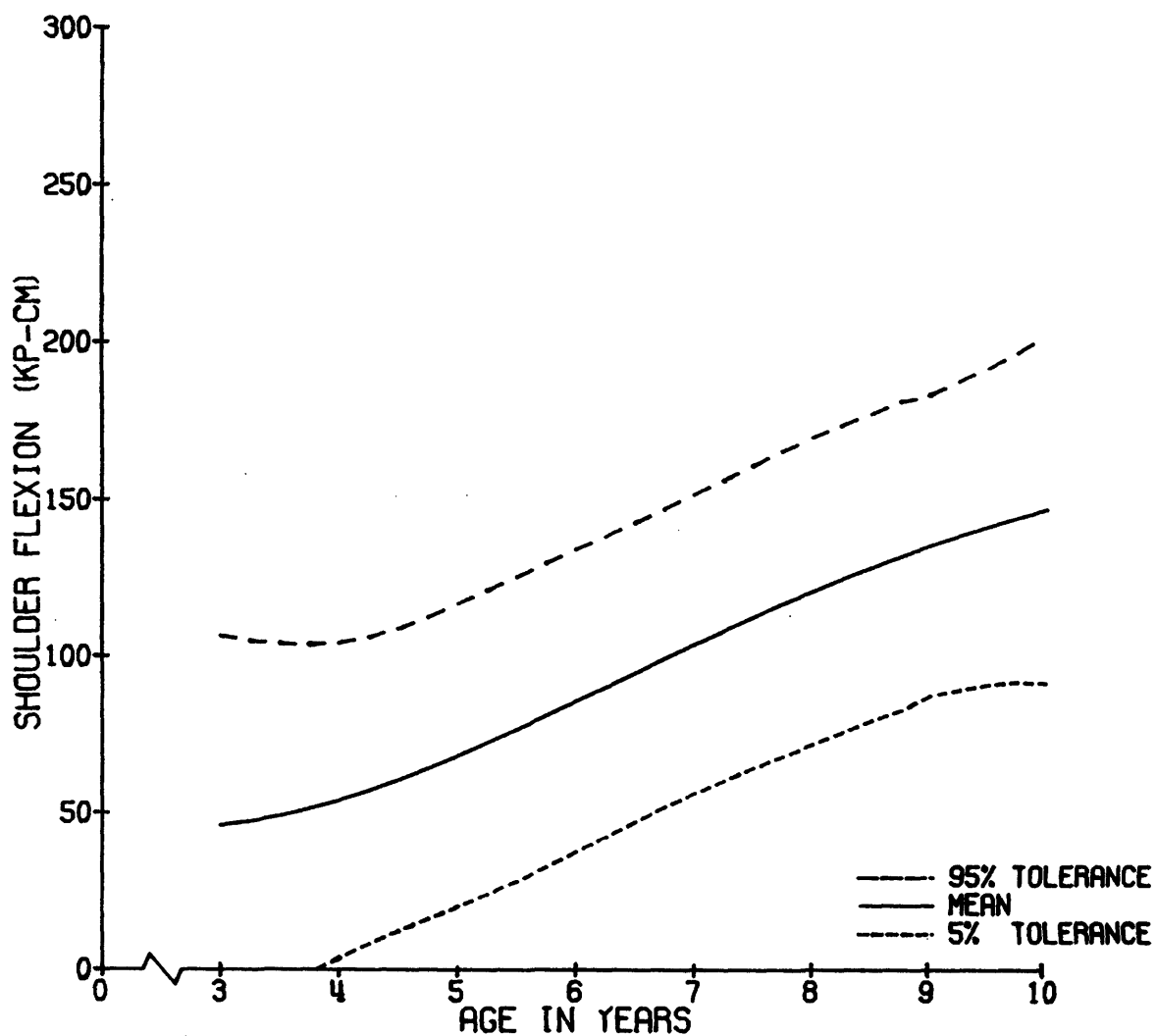

SHOULDER FLEXION, ° DEG. (KP-CM)

MALES

AGE	N	MEAN	ST. DEV	MIN	10%	MEDIAN	90%	MAX
3	7	44.0	11.5	23.9	23.9	48.3	58.1	58.1
4	33	62.3	19.1	26.2	32.4	63.9	86.4	94.5
5	35	74.0	24.0	30.1	44.8	71.7	104.8	130.9
6	38	83.7	25.2	38.0	56.0	77.7	127.4	136.2
7	35	105.0	22.7	59.4	74.0	107.5	134.8	156.7
8	37	128.3	32.5	60.0	92.9	122.0	171.2	196.2
9	38	148.3	38.5	82.1	98.4	146.4	177.6	276.9
10	16	163.0	44.8	89.7	109.9	162.3	227.1	232.4

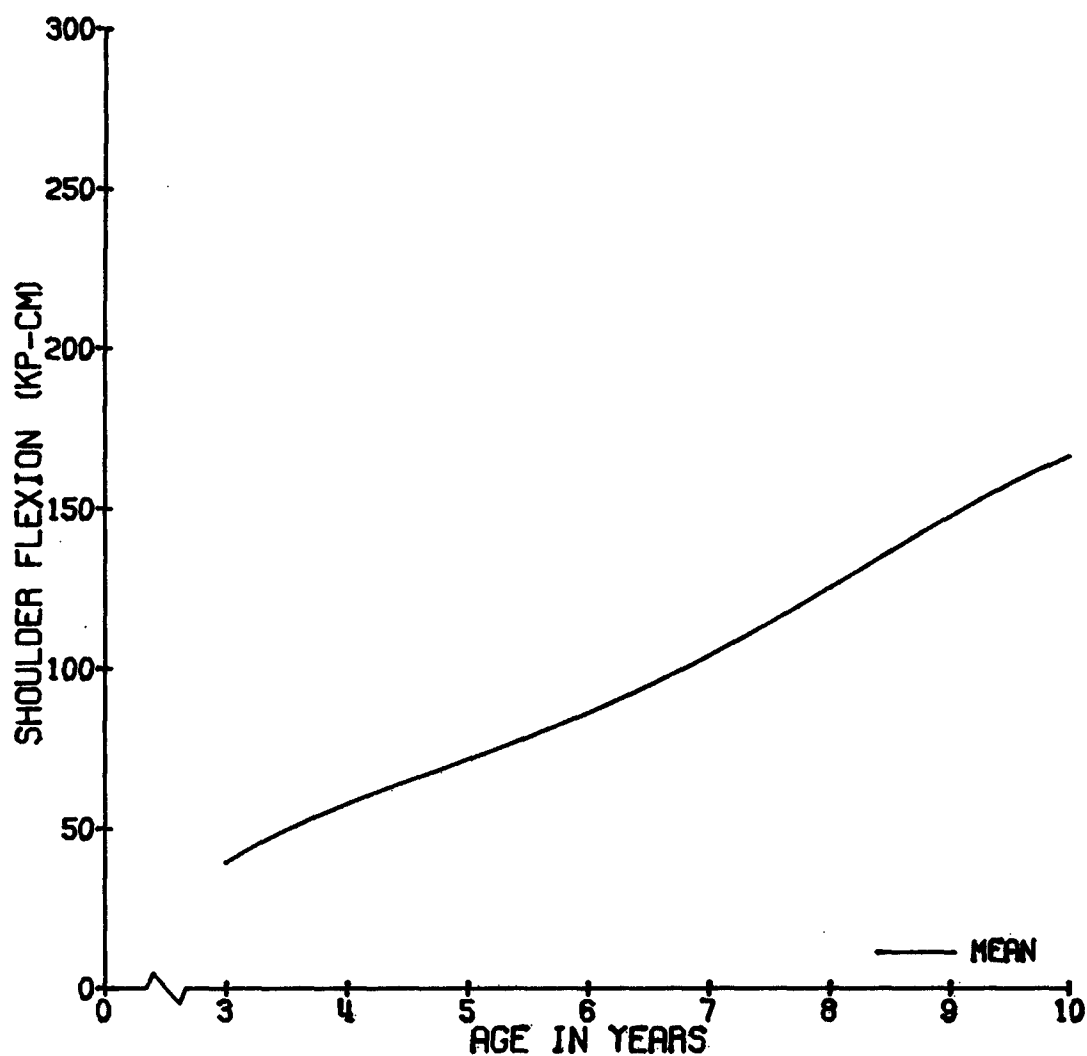

SHOULDER FLEXION, 0 DEG. (KP-CM)

FEMALES

AGE	N	MEAN	ST. DEV	MIN	10%	MEDIAN	90%	MAX
3	3	43.2	1.5	41.7	41.7	43.3	44.7	44.7
4	40	53.9	17.7	13.8	30.1	56.6	70.9	101.5
5	49	66.6	17.8	36.2	43.5	62.4	92.6	108.3
6	32	80.7	23.8	34.7	48.1	80.0	113.2	129.9
7	43	98.0	22.8	61.6	69.9	93.3	130.4	155.8
8	34	128.3	30.4	72.0	80.7	127.4	169.6	194.8
9	43	115.5	27.7	65.0	76.8	114.6	153.3	183.6
10	12	123.4	29.3	66.1	99.6	120.5	164.3	174.3

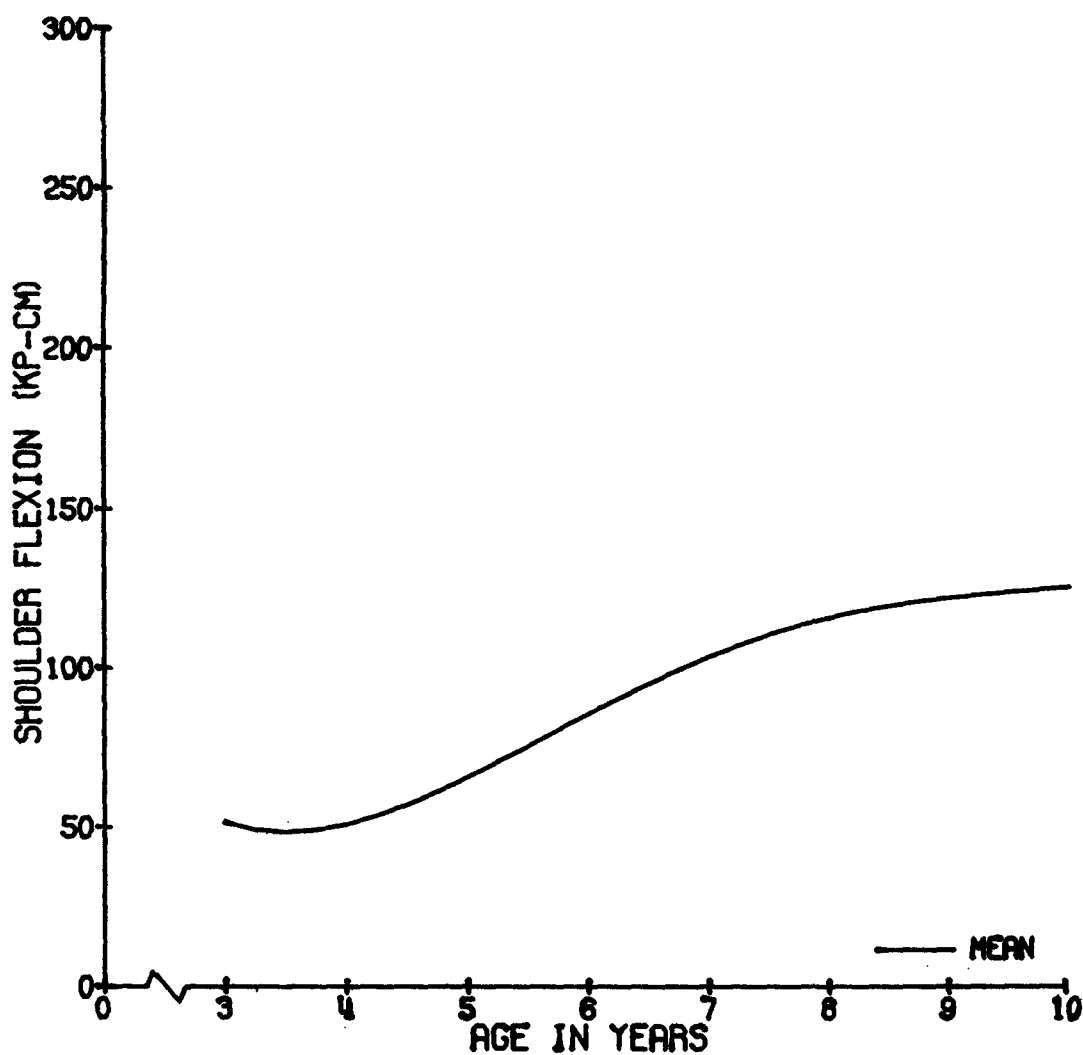

SHOULDER EXTENSION

DESCRIPTION OF TEST: The humerus is rotated posteriorly at the shoulder joint (glenohumeral joint center) in the sagittal plane.

TEST POSITION: The shoulder is abducted 5° , elbow flexed 90° , and wrist neutral at 0° . The right hand grasps a 2.5 cm diameter handle, the left forearm (distal to the humero-ulnar joint center) is unrestrained.

ANTHROPOMETRIC MEASUREMENT: The carpal, radial, humeral, sacral, and thoracolumbar linkages are measured with an anthropometer.

ADJUSTMENT OF EQUIPMENT: The chair back fixture is set to the sacral plus thoracolumbar length, aligning the shoulder joint center with that of the chair. The chair arm fixtures are set to the humeral and radial plus carpal lengths, aligning the elbow joint center and center of grip with those of the chair. Thin rubber pads are placed under the arm as needed to maintain these alignments. The shoulder abduction angle is locked at 5° and elbow flexion at 90° . The distal edge of the wrist support is adjusted to align with the wrist joint center. The wrist and arm straps are then secured snugly around the arm and the chest strap around the chest and left upper arm. The subject's right hand is placed to grasp the handle on the chair. His left forearm is placed in his lap.

INSTRUCTIONS TO SUBJECT; The child pulls his elbow (and hand) backward.

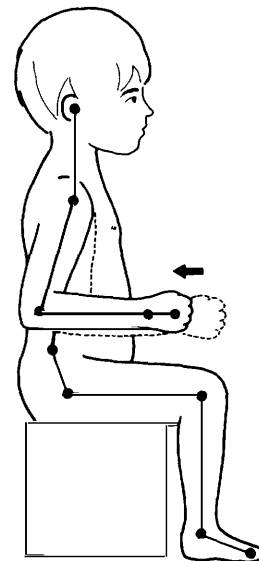

SHOULDER EXTENSION, 0 DEG. (KP-CM)

COMBINED SEXES

AGE	N	MEAN	ST. DEV	MIN	10%	MEDIAN	90%	MAX
3	10	39.4	11.5	19.7	19.7	41.2	46.0	61.4
4	74	53.6	17.9	23.4	37.1	58.8	81.2	107.8
5	81	70.3	22.0	20.4	40.3	69.1	100.5	122.1
6	70	89.3	26.8	39.6	52.2	88.3	122.5	147.7
7	79	113.0	37.6	6.7	70.4	105.7	162.4	233.1
8	71	139.1	35.8	69.9	95.8	136.6	188.2	246.2
9	81	151.7	42.8	64.3	97.7	153.7	206.5	264.4
10	28	187.3	63.8	107.9	122.1	170.5	319.0	334.5

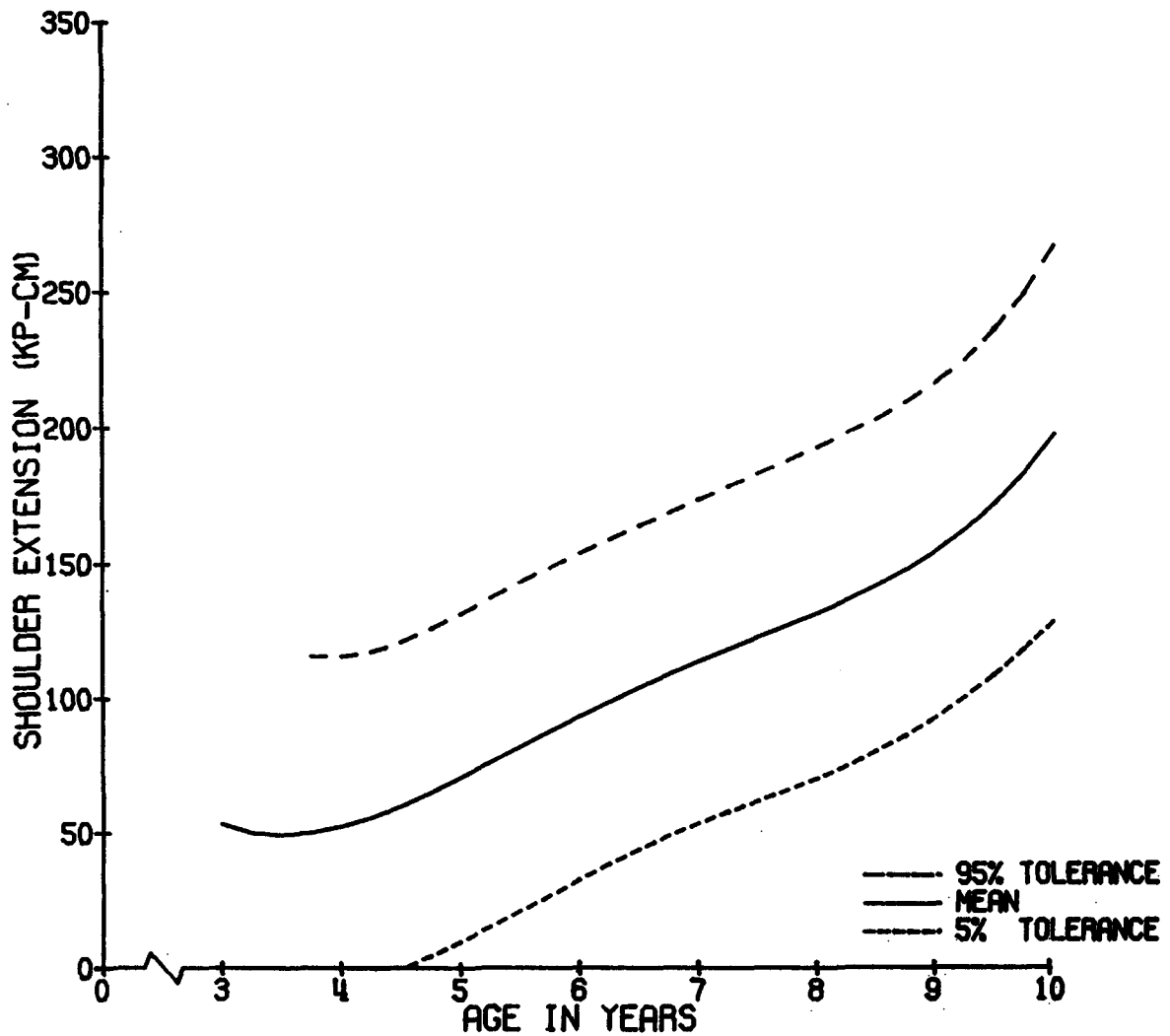

SHOULDER EXTENSION, 0 DEG. (KP-CM)

MALES

AGE	N	MEAN	ST. DEV	MIN	10%	MEDIAN	90%	MAX
3	6	43.5	9.8	32.7	32.7	41.9	61.4	61.4
4	32	61.9	15.5	23.4	40.7	59.7	87.9	107.8
5	32	76.2	22.2	20.4	47.4	75.9	105.3	122.1
6	38	90.4	23.0	48.7	53.8	88.8	119.6	133.5
7	36	123.5	44.1	56.7	73.6	111.8	192.8	233.1
8	37	145.1	39.4	69.9	95.8	133.9	200.4	246.2
9	38	165.7	45.7	95.4	124.5	156.7	245.3	264.4
10	16	203.3	60.1	117.3	144.0	181.7	327.8	334.5

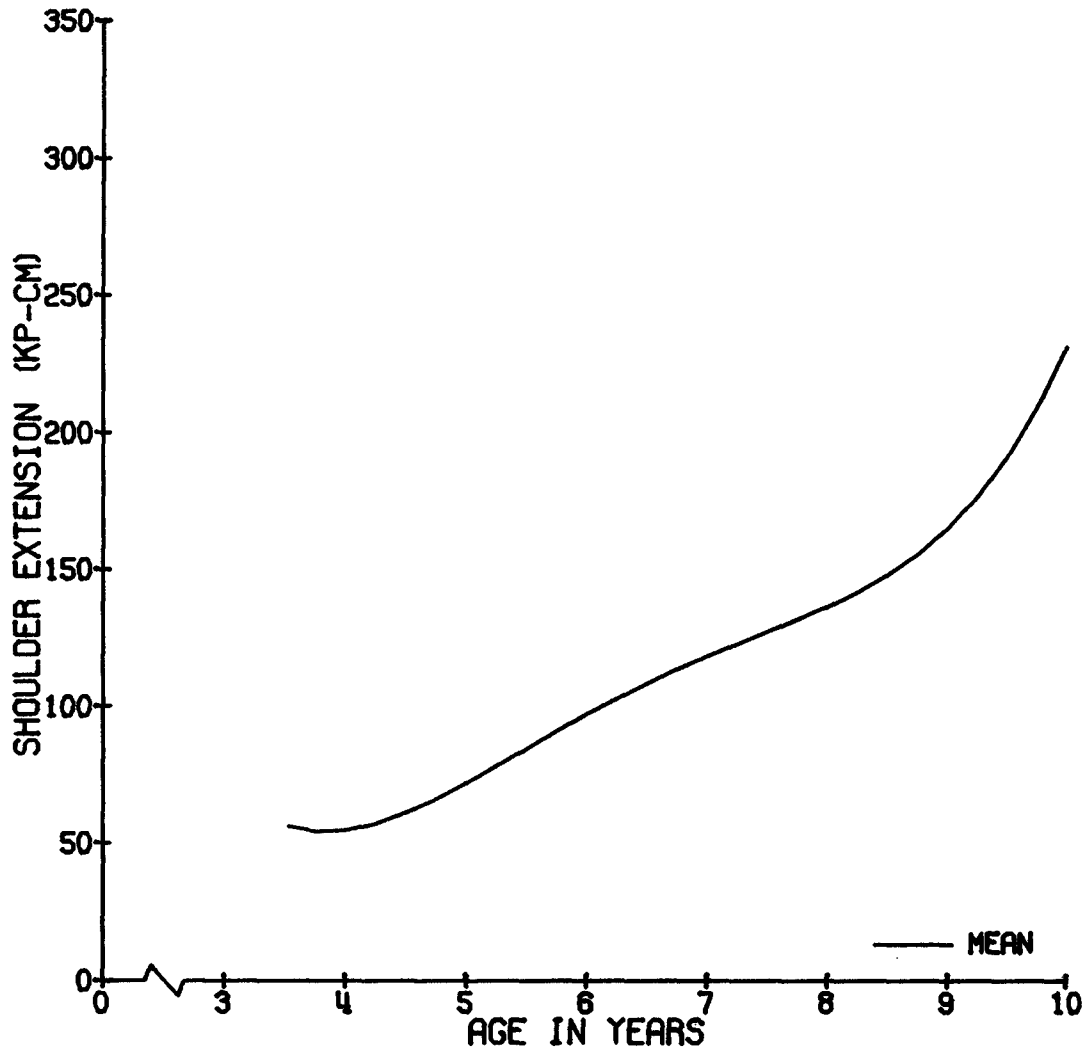

SHOULDER EXTENSION, 0 DEG. (KP-CM)

FEMALES

AGE	N	MEAN	ST. DEV	MIN	10%	MEDIAN	90%	MAX
3	4	33.0	12.1	19.7	19.7	33.8	44.7	44.7
4	42	56.1	16.3	27.5	32.5	56.2	73.1	98.1
5	49	66.5	21.2	29.6	37.2	67.3	93.8	119.2
6	32	88.1	31.2	39.6	50.9	85.2	136.3	147.7
7	43	106.6	30.3	6.7	70.4	103.6	143.3	157.6
8	34	132.0	30.7	74.0	95.5	131.1	176.1	201.5
9	43	139.2	41.2	64.3	82.5	137.6	195.5	240.1
10	12	160.5	45.5	107.9	122.1	149.4	207.8	267.0

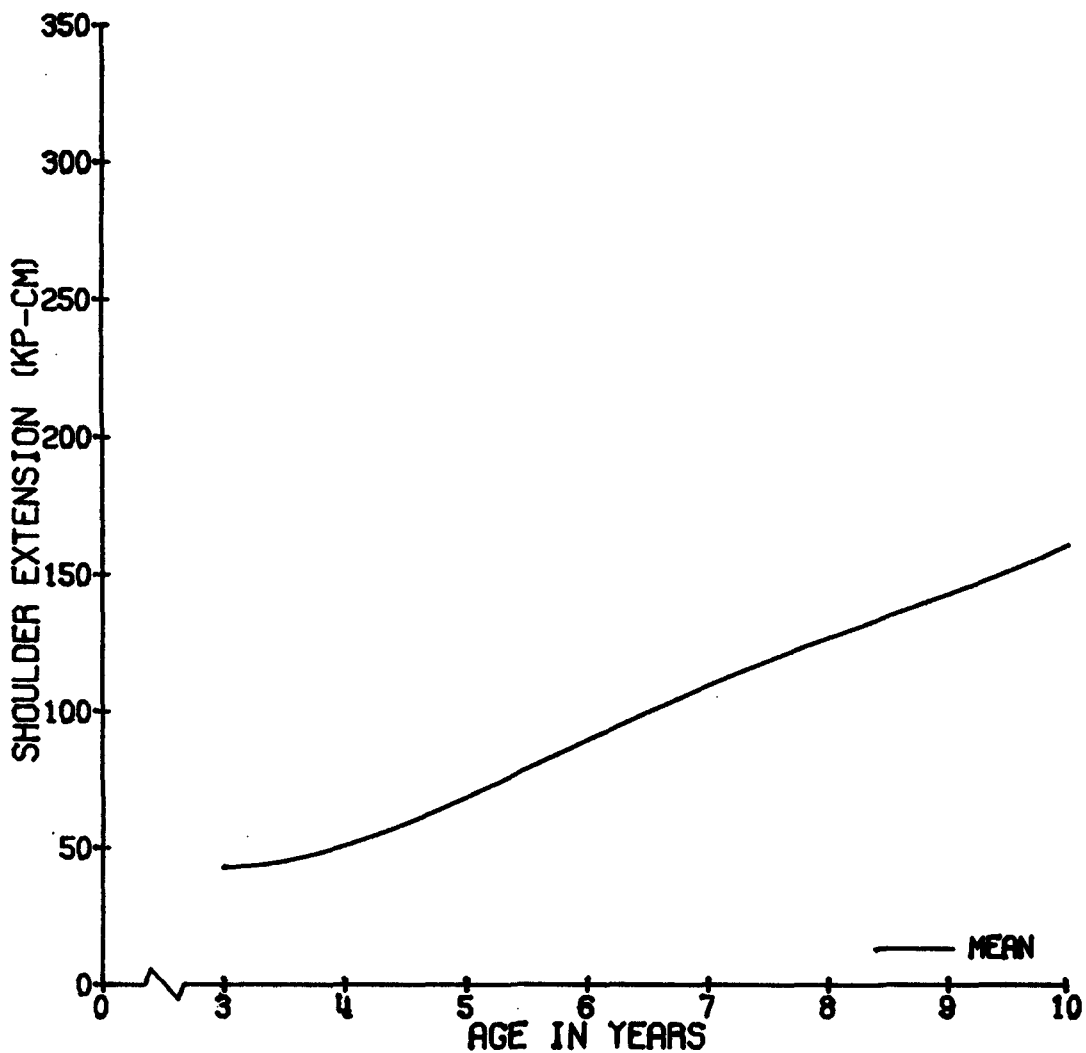

SHOULDER ADDUCTION

DESCRIPTION OF TEST: The humerus is rotated at the shoulder joint (glenohumeral joint center) in the coronal plane toward the midline of the body in a medially direction.

TEST POSITION: The shoulder is abducted 5° , elbow flexed 90° , and wrist neutral at 0° . The right hand grasps a 2.5 cm diameter handle, the left forearm (distal to the humero-ulnar joint center) is unrestrained.

ANTHROPOMETRIC MEASUREMENTS: The carpal, radial, humeral, sacral, and thoracolumbar linkages are measured with an anthropometer.

ADJUSTMENT OF EQUIPMENT: The chair back fixture is set to the sacral plus thoracolumbar length, aligning the shoulder joint center with that of the chair. The chair arm fixtures are set to the humeral and radial plus carpal lengths, aligning the elbow joint center and center of grip with those of the chair. Thin rubber pads are placed under the arm as needed to maintain these alignments. The shoulder abduction angle is locked at 5° and elbow flexion at 90° . The distal edge of wrist support is adjusted to align with the wrist joint center. The wrist and arm straps are then secured snugly around the arm and the chest strap around the chest and left upper arm. The subject's right hand is placed to grasp the handle on the chair. His left forearm is placed in his lap.

INSTRUCTIONS TO SUBJECT: The child pulls his elbow toward his body.

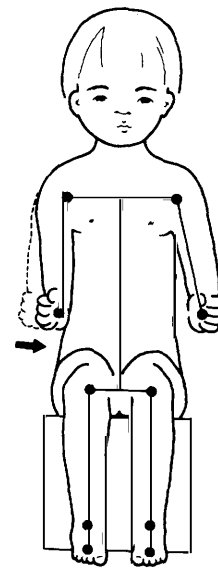

SHOULDER ADDUCTION, 5 DEG. (KP-CM)

COMBINED SEXES

AGE	N	MEAN	ST. DEV	MIN	10%	MEDIAN	90%	MAX
3	10	43.0	27.3	15.0	15.0	36.9	81.0	96.3
4	37	69.7	32.5	20.6	28.4	63.3	114.8	159.9
5	36	82.7	33.3	31.7	47.7	77.6	133.6	173.3
6	58	109.9	39.9	25.7	62.7	108.2	158.4	206.7
7	73	133.8	52.4	41.2	61.4	130.8	201.3	316.4
8	70	172.4	53.9	82.7	105.3	164.6	240.5	331.4
9	81	178.1	63.4	28.3	106.7	179.8	254.8	415.5
10	28	238.0	87.8	88.9	111.7	234.1	362.6	424.6

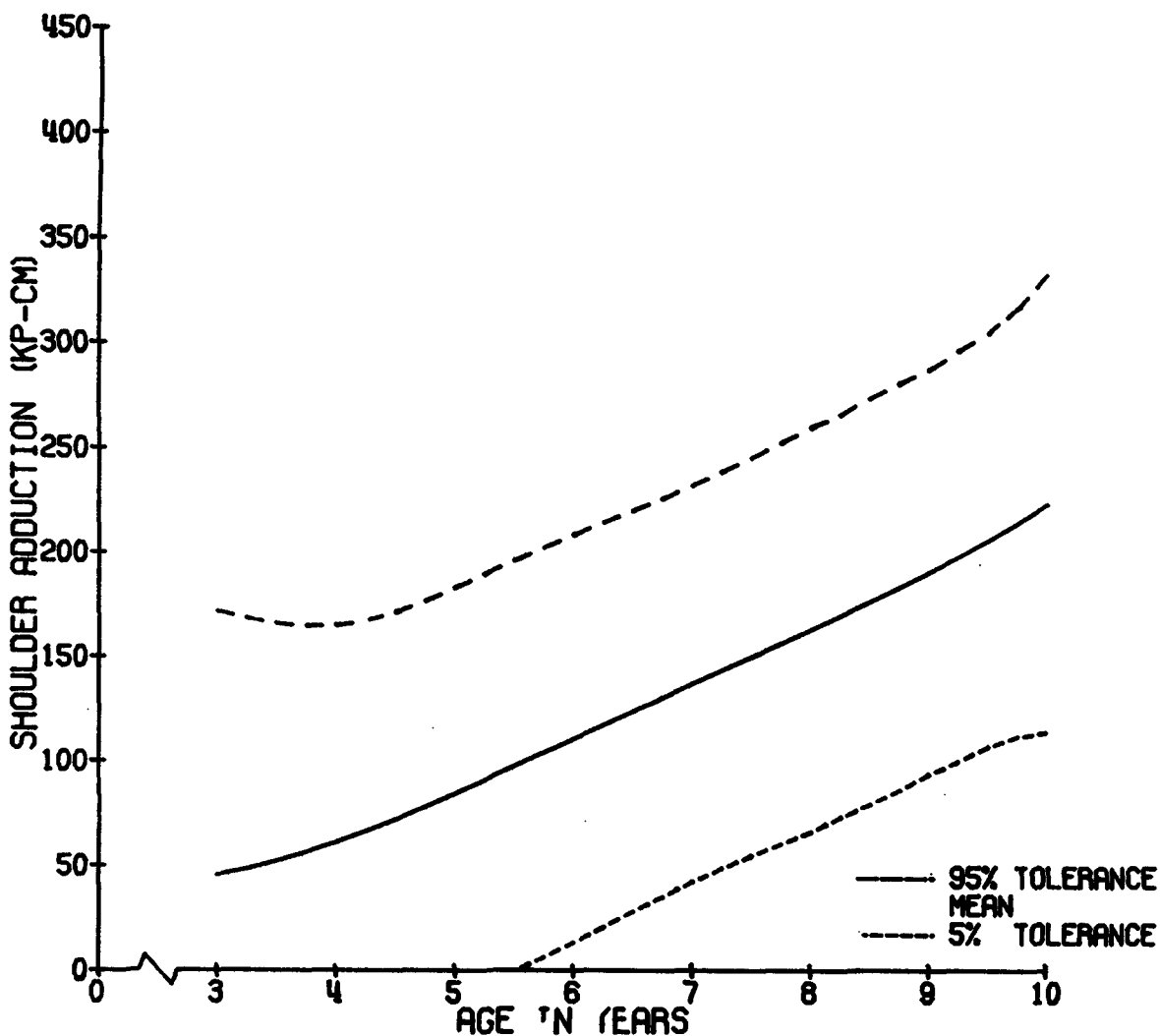

SHOULDER ADDUCTION, 5 DEG. (KP-CM)

MALES

AGE	N	MEAN	ST. DEV	MIN	10%	MEDIAN	90%	MAX
3	8	43.4	30.8	15.0	15.0	30.1	96.3	96.3
4	19	74.6	33.5	32.2	33.9	65.4	118.7	159.9
5	12	91.8	42.6	43.3	48.2	86.8	171.2	173.3
6	33	118.8	35.7	62.9	76.5	116.2	169.6	206.7
7	35	143.2	58.9	51.3	61.4	141.5	219.3	316.4
8	37	173.4	55.0	90.2	109.1	166.1	243.7	331.4
9	39	196.4	63.3	28.3	125.0	204.8	258.9	415.5
10	16	272.4	85.9	111.7	175.6	278.1	381.5	424.6

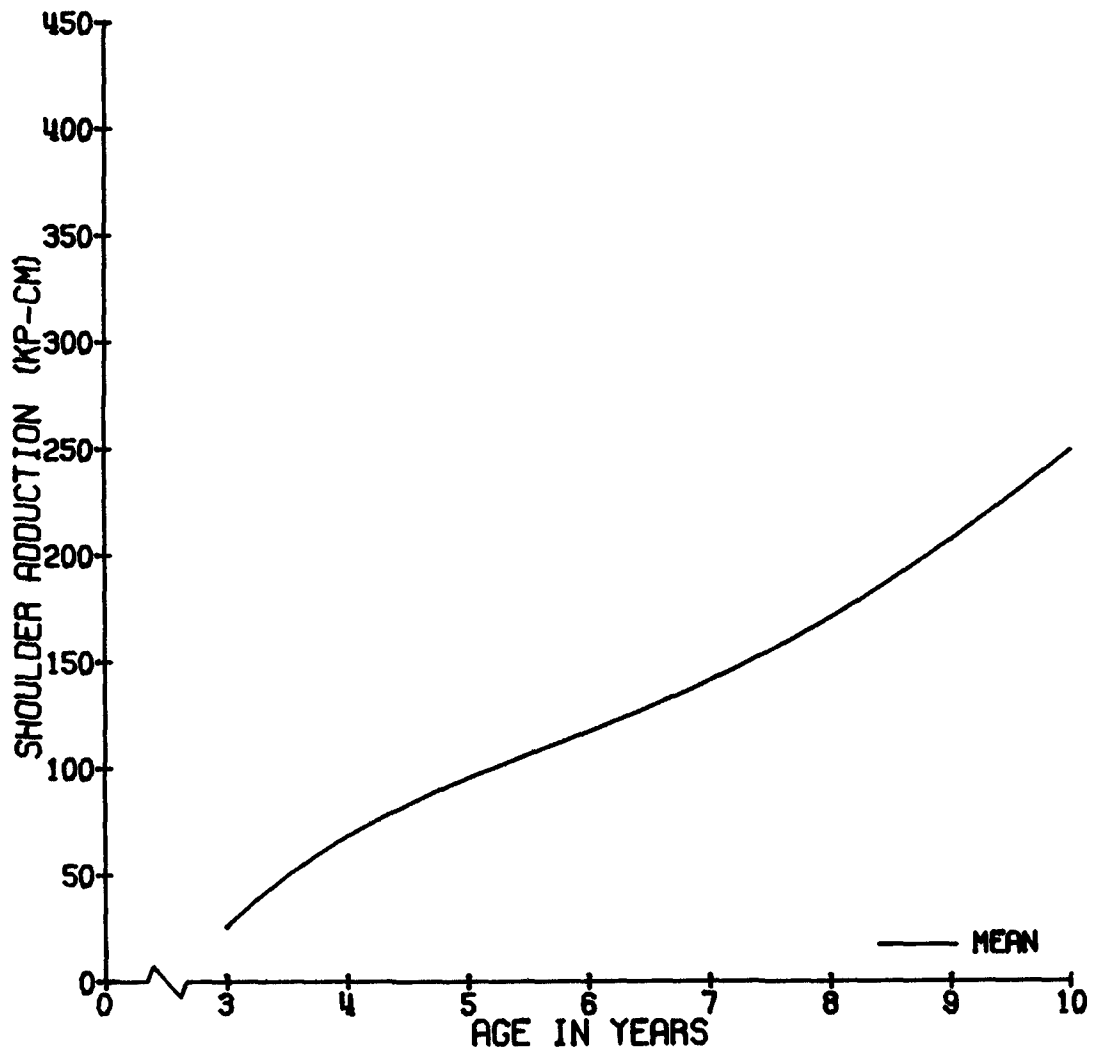

SHOULDER ADDUCTION, 5 DEG. (KP-CM)

FEMALES

AGE	N	MEAN	ST. DEV	MIN	10%	MEDIAN	90%	MAX
3	2	41.2	5.3	37.5	37.5	41.2	45.0	45.0
4	18	64.5	31.6	29.6	22.1	58.7	112.1	114.8
5	24	78.2	27.5	31.7	47.7	75.0	115.3	136.0
6	25	98.1	42.7	25.7	47.5	97.2	158.0	195.3
7	43	126.2	45.8	41.2	62.2	126.3	189.9	231.6
8	33	171.3	53.5	82.7	105.3	157.8	240.5	289.4
9	43	162.0	59.6	48.7	93.8	151.4	242.2	293.6
10	12	192.1	69.7	88.9	107.7	182.3	286.0	294.4

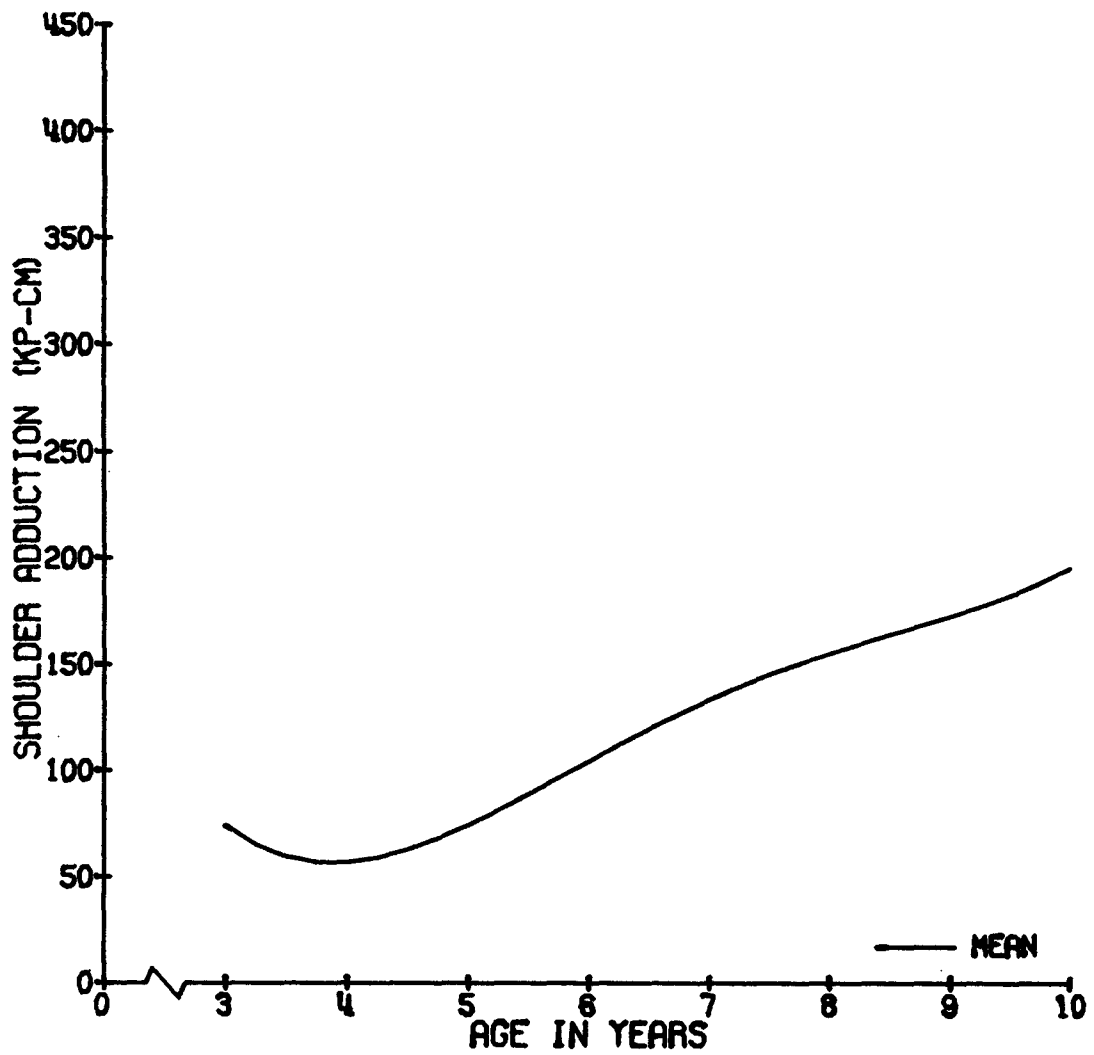

SHOULDER ABDUCTION

DESCRIPTION OF TEST: The humerus is rotated at the shoulder joint (glenohumeral joint center) in the coronal plane away from the midline of the body in a lateral direction.

TEST POSITION: The shoulder is abducted 5° , elbow flexed 90° and wrist neutral at 0° . The right hand grasps a 2.5 cm diameter handle, the left forearm (distal to the humero-ulnar joint center) is unrestrained.

ANTHROPOMETRIC MEASUREMENTS: The carpal, radial, humeral, sacral and thoracolumbar linkages are measured with an anthropometer.

ADJUSTMENT OF EQUIPMENT: The chair back fixture is set to the sacral plus thoracolumbar length, aligning the shoulder joint center with that of the chair. The chair arm fixtures are set to the humeral and radial plus carpal lengths, aligning the elbow joint center and center grip with those of the chair. Thin rubber pads are placed under the arm as needed to maintain these alignments. The shoulder abduction angle is locked at 5° and elbow flexion at 90° . The distal edge of the wrist support is adjusted to align with the wrist joint center. The wrist and arm straps are then secured snugly around the arm and the chest strap around the chest and left upper arm. The subject's right hand is placed to grasp the handle on the chair. His left forearm is placed in his lap.

INSTRUCTIONS TO SUBJECT: The child pushes his elbow away from his body.

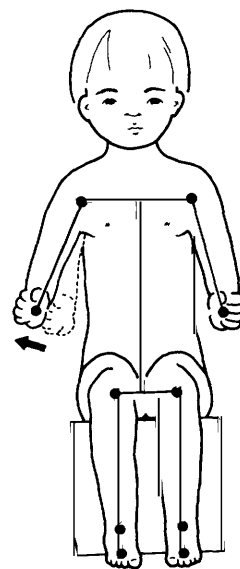

SHOULDER ABDUCTION, 5 DEG. (KP-CM)

COMBINED SEXES

AGE	N	MEAN	ST. DEV	MIN	10%	MEDIAN	90%	MAX
3	8	53.1	29.5	16.6	16.6	50.8	110.0	110.0
4	37	61.6	26.9	24.7	32.8	56.1	88.2	151.9
5	36	72.9	36.9	23.0	35.1	71.1	124.1	191.8
6	58	94.2	42.0	27.1	45.6	83.2	158.5	219.4
7	78	113.0	54.2	35.1	58.5	93.9	189.4	284.3
8	71	144.4	70.5	46.1	71.1	125.1	247.3	397.1
9	80	163.6	68.5	24.8	83.4	150.8	245.6	354.2
10	28	224.5	86.5	66.9	131.4	215.9	375.2	396.0

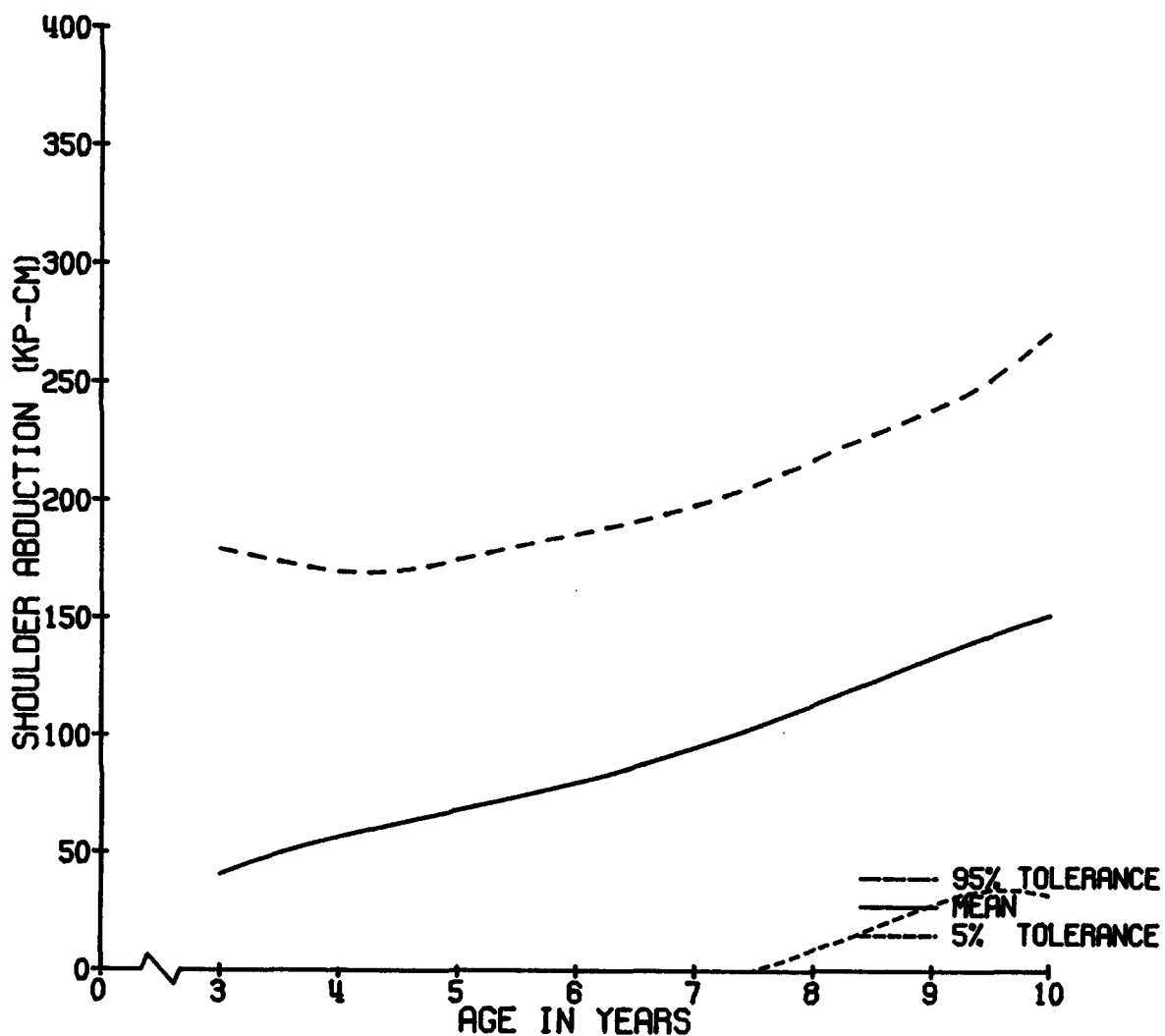

SHOULDER ABDUCTION, 5 DEG. (KP-CM)

MALES

AGE	N	MEAN	ST. DEV	MIN	10%	MEDIAN	90%	MAX
3	6	49.0	33.7	16.6	16.6	38.4	110.0	110.0
4	19	65.7	28.4	32.8	38.1	56.1	100.8	151.9
5	12	84.8	44.5	23.0	44.0	81.8	126.3	191.8
6	33	95.2	43.2	35.6	47.5	83.6	160.4	219.4
7	35	122.6	58.1	56.0	67.0	109.6	216.4	284.3
8	37	145.6	65.3	56.1	85.1	126.0	258.3	313.9
9	37	181.9	66.8	78.4	107.4	167.8	273.6	354.2
10	10	220.0	98.1	66.9	109.5	190.2	375.2	396.0

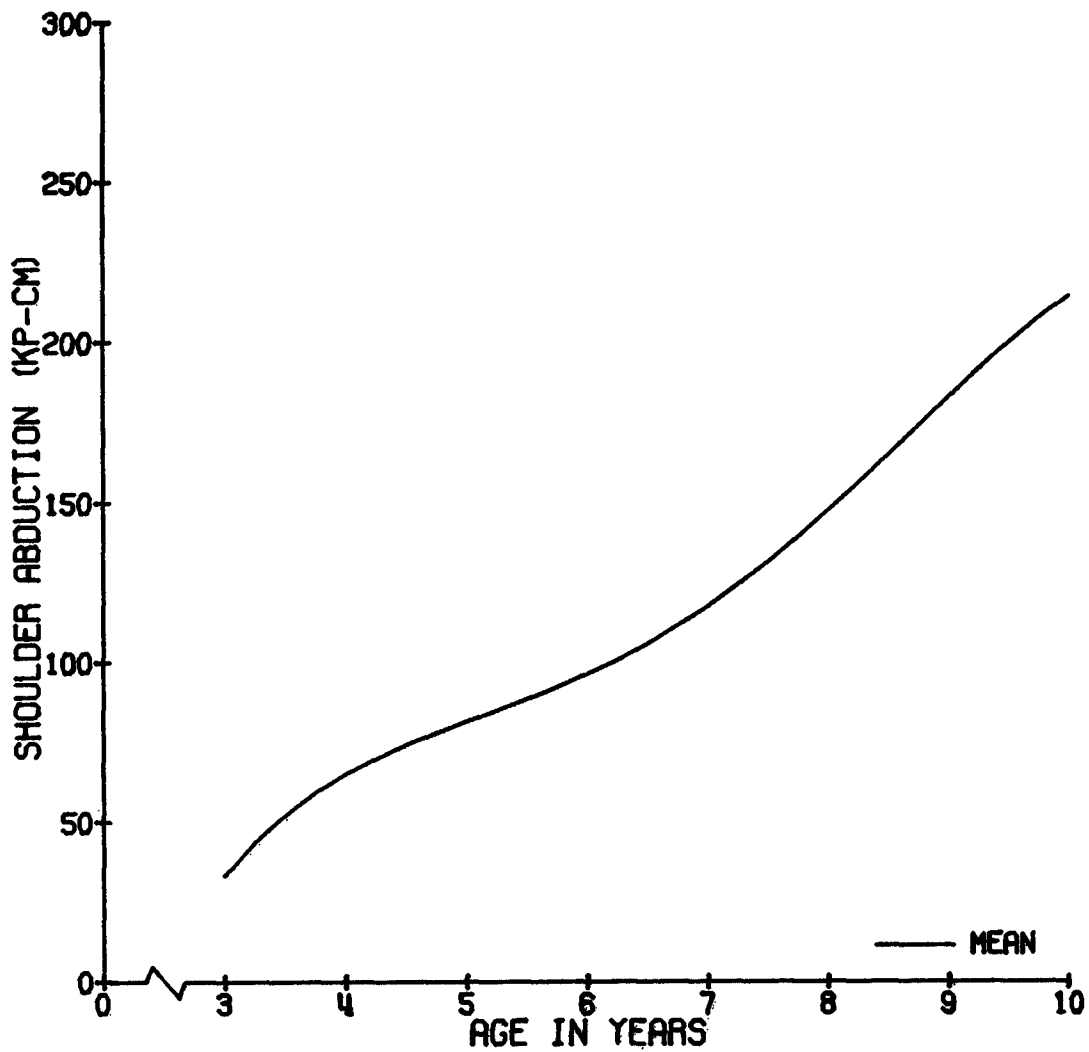

SHOULDER ABDUCTION, 5 DEG. (KP-CM)

FEMALES

AGE	N	MEAN	ST. DEV	MIN	10%	MEDIAN	90%	MAX
3	2	65.1	4.7	61.8	61.8	65.1	68.5	68.5
4	18	57.2	25.2	24.7	24.8	54.6	82.1	133.2
5	24	67.0	31.8	24.8	35.1	56.7	108.6	155.9
6	25	92.9	41.3	27.1	43.3	78.4	151.8	178.7
7	43	105.2	50.1	35.1	49.2	85.9	178.6	233.0
8	34	143.1	76.7	46.1	63.9	123.3	247.0	397.1
9	43	147.9	66.7	24.8	79.2	139.7	244.8	321.8
10	12	230.5	71.9	146.4	156.4	226.0	316.2	395.2

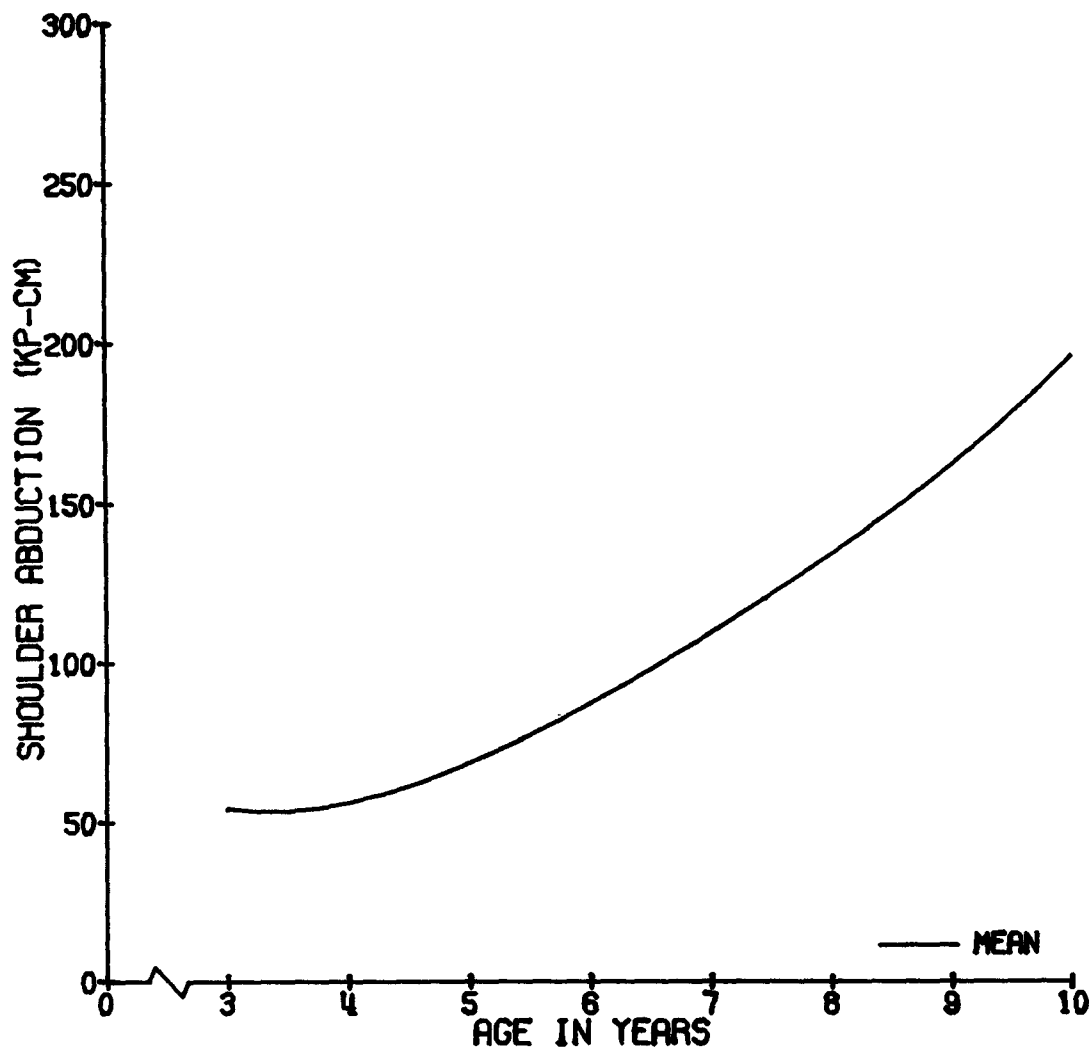

SHOULDER MEDIAL ROTATION

DESCRIPTION OF TEST: The humerus is rotated at the shoulder joint (glenohumeral joint center) around its longitudinal axis, rotating the anterior surface of the humerus medially toward the midline of the body.

TEST POSITION: The shoulder is abducted 5° , elbow flexed 90° and wrist neutral at 0° . The right hand grasps a 2.5 cm diameter handle, the left forearm (distal to the humero-ulnar joint center) is unrestrained.

ANTHROPOMETRIC MEASUREMENTS: The carpal, radial, humeral, sacral and thoracolumbar linkages are measured with an anthropometer.

ADJUSTMENT OF EQUIPMENT: The chair back fixture is set to the sacral plus thoracolumbar length, aligning the shoulder joint center with that of the chair. The chair arm fixtures are set to the humeral and radial plus carpal lengths, aligning the elbow joint center and center of grip with those of the chair. Thin rubber pads are placed under the arm as needed to maintain these alignments. The shoulder abduction angle is locked at 5° and elbow flexion at 90° . The distal edge of the wrist support is adjusted to align with the wrist joint center. The wrist and arm straps are then secured snugly around the arm and the chest strap around the chest and left upper arm. The subject's right hand is placed to grasp the handle on the chair. His left forearm is placed in his lap.

INSTRUCTIONS TO THE SUBJECT: The child pulls his wrist toward his body and his elbow away from his body.

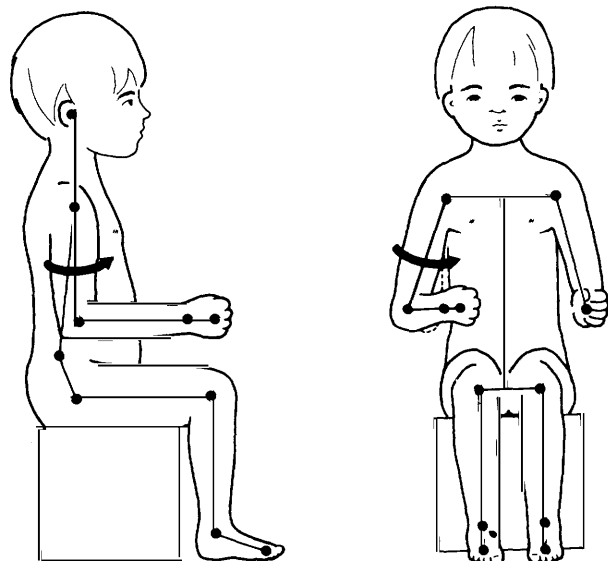

SHOULDER MEDIAL ROTATION, 0 DEG. (KP-CM)

COMBINED SEXES

AGE	N	MEAN	ST. DEV	MIN	10%	MEDIAN	90%	MAX
3	10	51.6	15.0	32.0	32.0	45.2	69.3	71.0
4	37	61.6	21.3	18.8	38.7	58.0	93.0	116.6
5	30	78.1	30.2	32.5	41.5	75.6	112.8	157.4
6	45	104.3	25.9	58.7	75.1	103.3	138.3	179.3
7	78	127.9	29.3	67.3	87.4	127.2	164.1	207.1
8	71	166.0	41.6	75.0	112.8	169.2	221.4	274.0
9	81	172.4	53.2	37.3	108.4	175.1	235.2	323.9
10	28	204.5	57.1	108.5	132.2	190.5	287.1	322.1

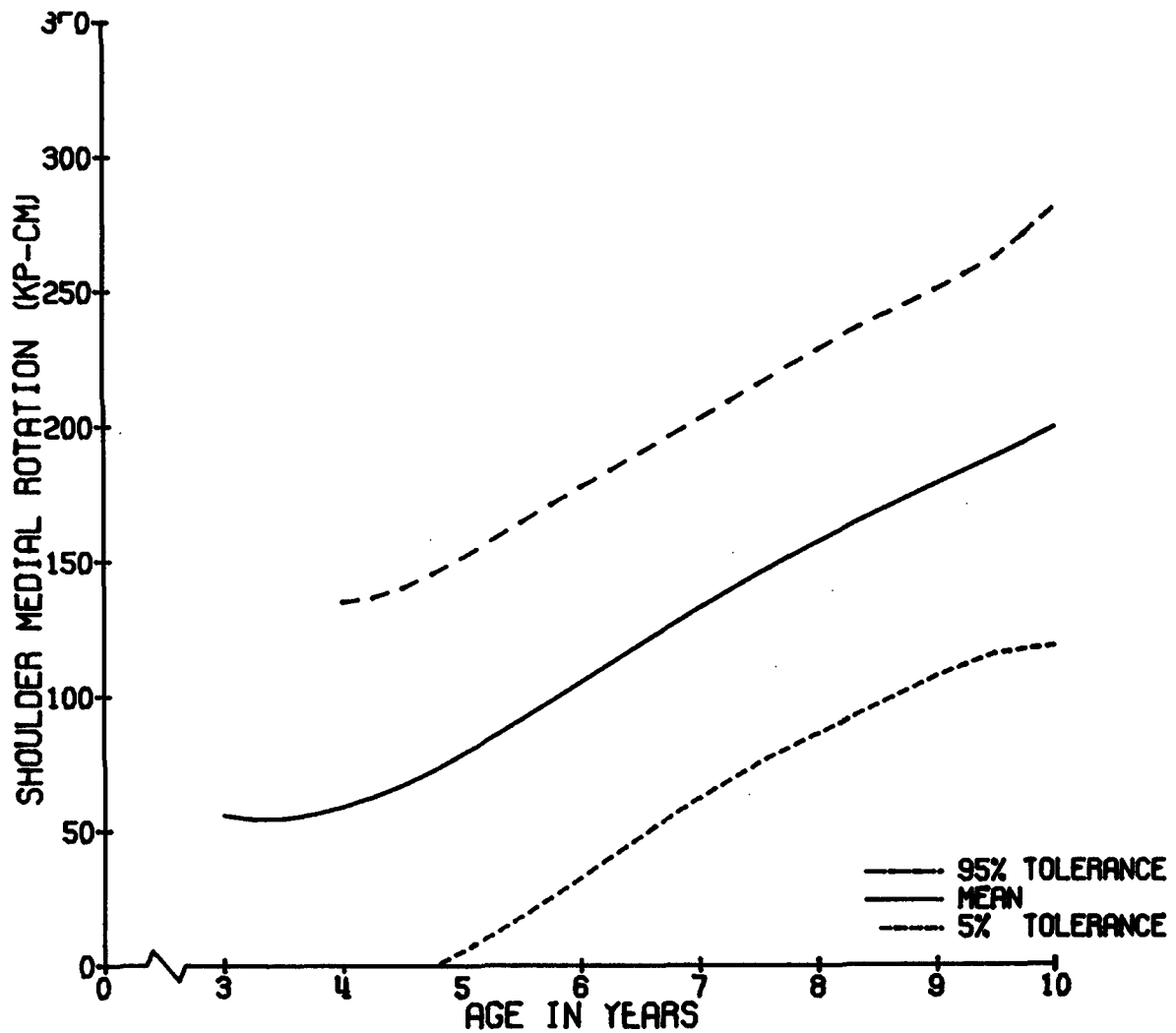

SHOULDER MEDIAL ROTATION, 0 DEG. (KP-CM) MALES

AGE	N	MEAN	ST. DEV	MIN	10%	MEDIAN	90%	MAX
3	8	50.7	15.1	32.0	32.0	45.2	71.0	71.0
4	19	63.4	22.0	37.4	38.7	61.2	102.2	116.6
5	9	81.6	47.7	33.5	33.5	56.7	157.4	157.4
6	27	106.7	27.2	58.7	75.1	106.2	138.3	179.3
7	35	133.4	31.8	71.9	92.9	126.4	179.4	207.1
8	37	174.1	44.0	75.0	122.6	173.0	237.7	274.0
9	38	201.3	49.1	129.2	135.6	193.4	273.8	323.9
10	16	234.1	54.3	132.2	134.5	241.5	302.5	322.1

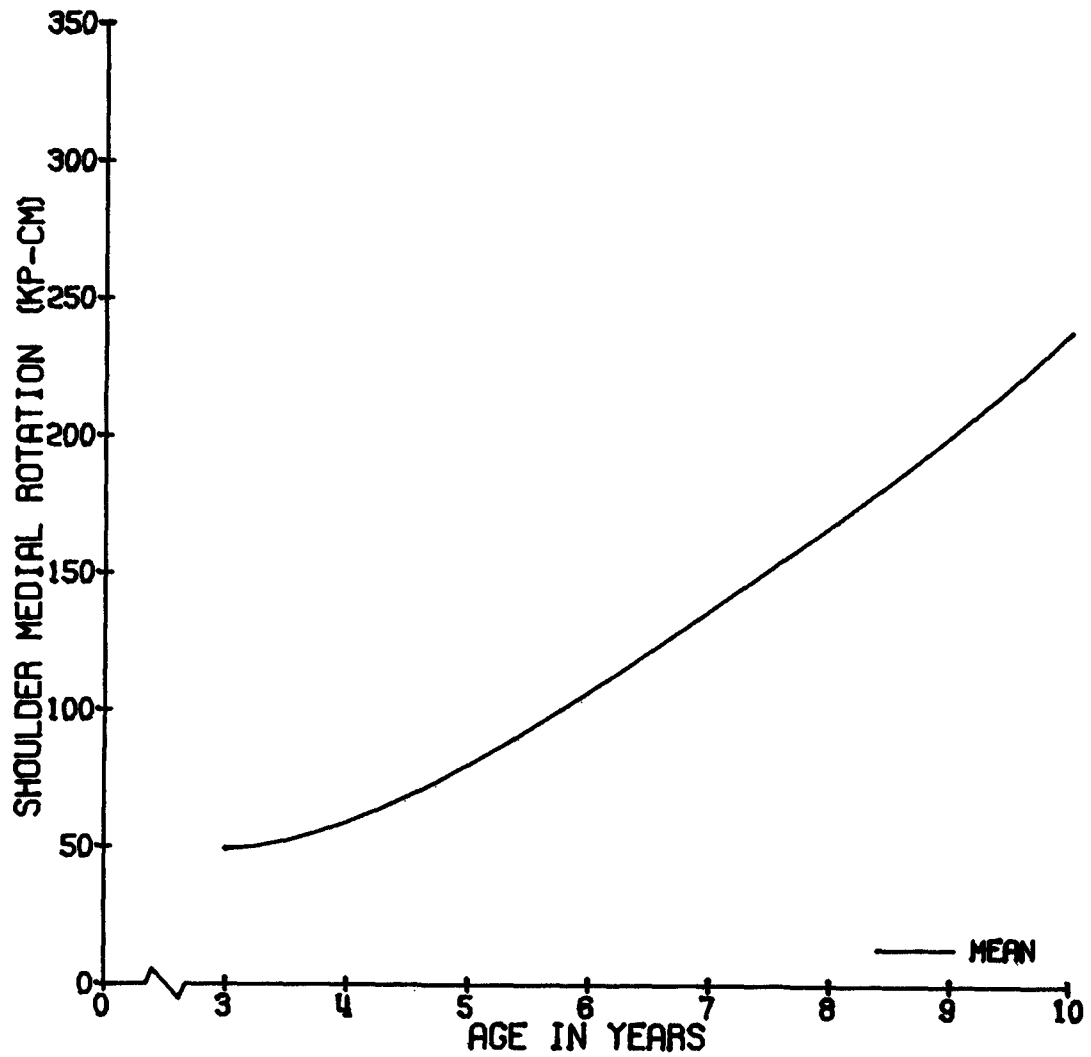

SHOULDER MEDIAL ROTATION, 0 DEG. (KP-CM)

FEMALES

AGE	N	MEAN	ST. DEV	MIN	10%	MEDIAN	90%	MAX
3	2	55.2	19.9	41.1	41.1	55.2	69.3	69.3
4	18	59.8	21.0	18.8	34.1	56.1	93.0	107.1
5	21	76.6	20.1	32.5	50.9	77.7	102.5	112.8
6	18	100.7	24.0	69.0	73.0	99.8	141.2	145.1
7	43	123.5	26.6	67.3	82.1	127.5	156.2	175.8
8	34	157.1	37.4	92.0	107.1	163.3	198.3	222.3
9	43	146.9	43.0	37.3	100.1	147.7	195.1	220.9
10	12	165.1	32.1	108.5	119.3	167.6	191.8	226.2

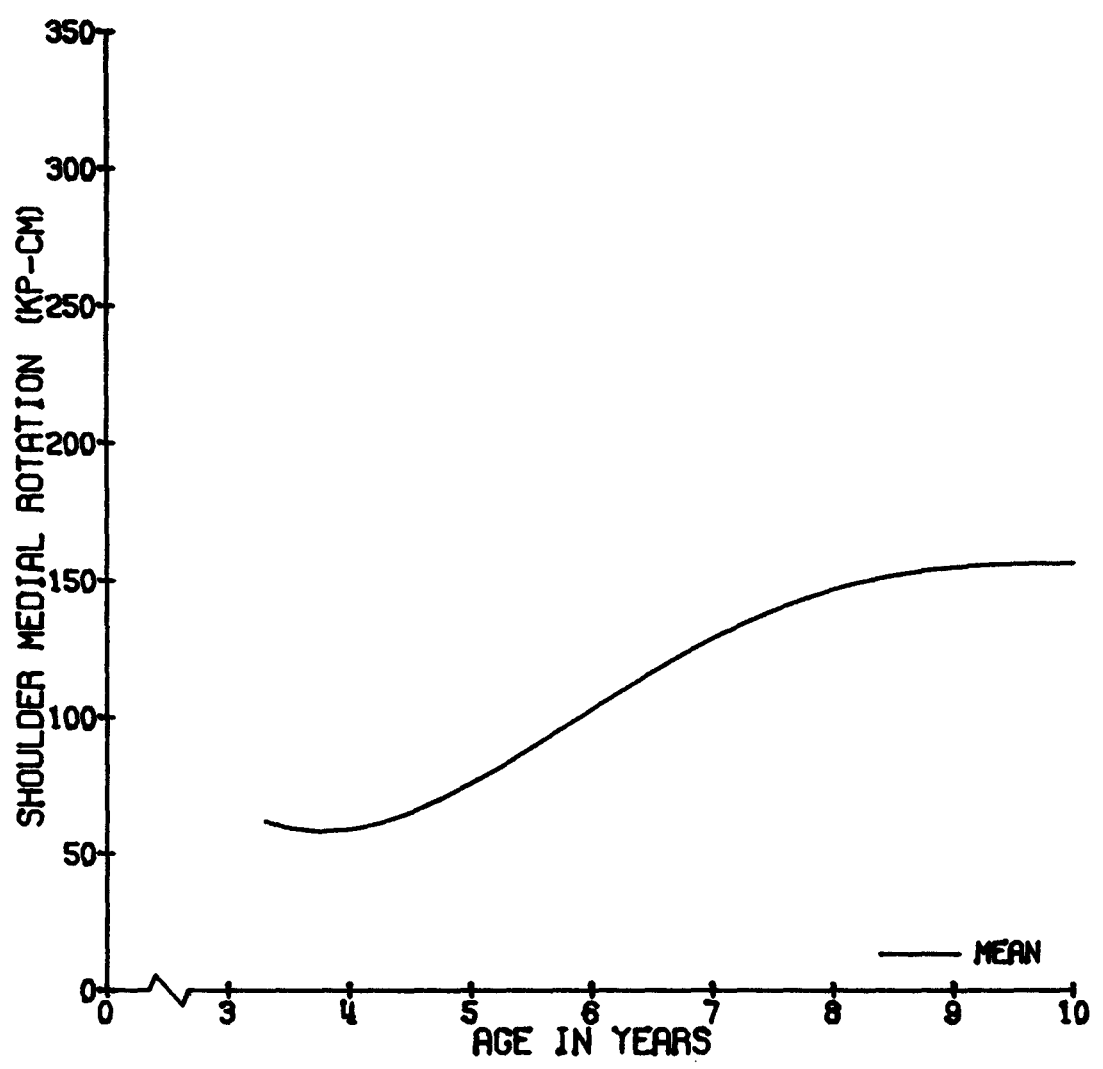

SHOULDER LATERAL ROTATION

DESCRIPTION OF TEST: The humerus is rotated at the shoulder joint (glenohumeral joint center) around its longitudinal axis, moving the anterior surface of the humerus laterally away from the midline of the body.

TEST POSITION: The shoulder is abducted 5° , elbow flexed 90° and wrist neutral at 0° . The right hand grasps a 2.5 cm diameter handle, the left forearm (distal to the humero-ulnar joint center) is unrestrained.

ANTHROPOMETRIC MEASUREMENTS: The carpal, radial, humeral, sacral and thoracolumbar linkages are measured with an anthropometer.

ADJUSTMENT OF EQUIPMENT: The chair back fixture is set to the sacral plus thoracolumbar length, aligning the shoulder joint center with that of the chair. The chair arm fixtures are set to the humeral and radial plus carpal lengths, aligning the elbow joint center and center of grip with those of the chair. Thin rubber pads are placed under the arm as needed to maintain these alignments. The shoulder abduction angle is locked at 5° and elbow flexion at 90° . The distal edge of the wrist support is adjusted to align with the wrist joint center. The wrist and arm straps are then secured snugly around the arm and the chest strap around the chest and left upper arm. The subject's right hand is placed to grasp the handle on the chair. His left forearm is placed in his lap.

INSTRUCTIONS TO SUBJECT: The child pushes his wrist away from his body and his elbow toward his body.

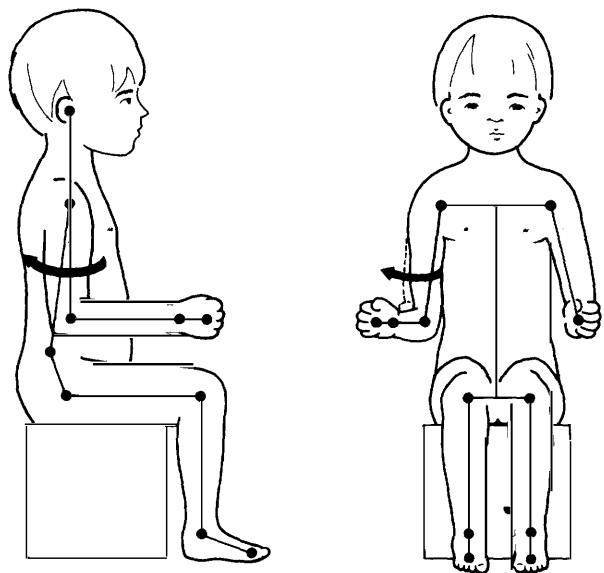
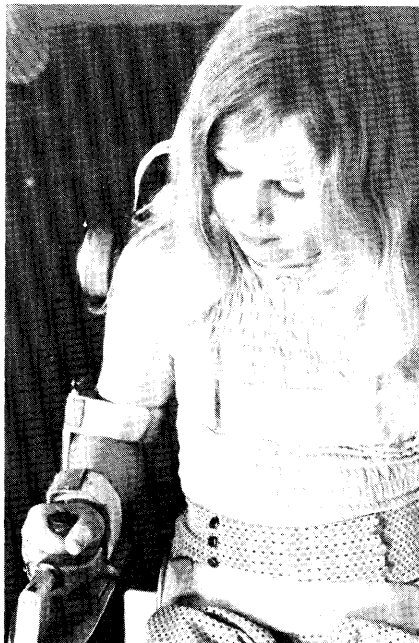

SHOULDER LATERAL ROTATION, 0 DEG. (KP-CM)

COMBINED SEXES

AGE	N	MEAN	ST. DEV	MIN	10%	MEDIAN	90%	MAX
3	8	41.6	15.2	16.4	16.4	44.4	63.4	63.4
4	37	49.1	19.1	16.5	25.9	46.7	75.9	91.9
5	30	57.1	21.8	26.2	28.0	56.2	77.5	113.9
6	45	72.1	20.8	43.8	51.2	69.1	98.1	156.5
7	78	88.6	21.5	52.1	61.8	85.6	116.2	149.3
8	71	107.8	31.2	40.5	71.3	104.6	152.7	195.6
9	80	113.6	34.9	37.1	66.1	112.6	151.9	210.1
10	28	120.7	34.7	50.4	68.8	120.3	164.6	193.5

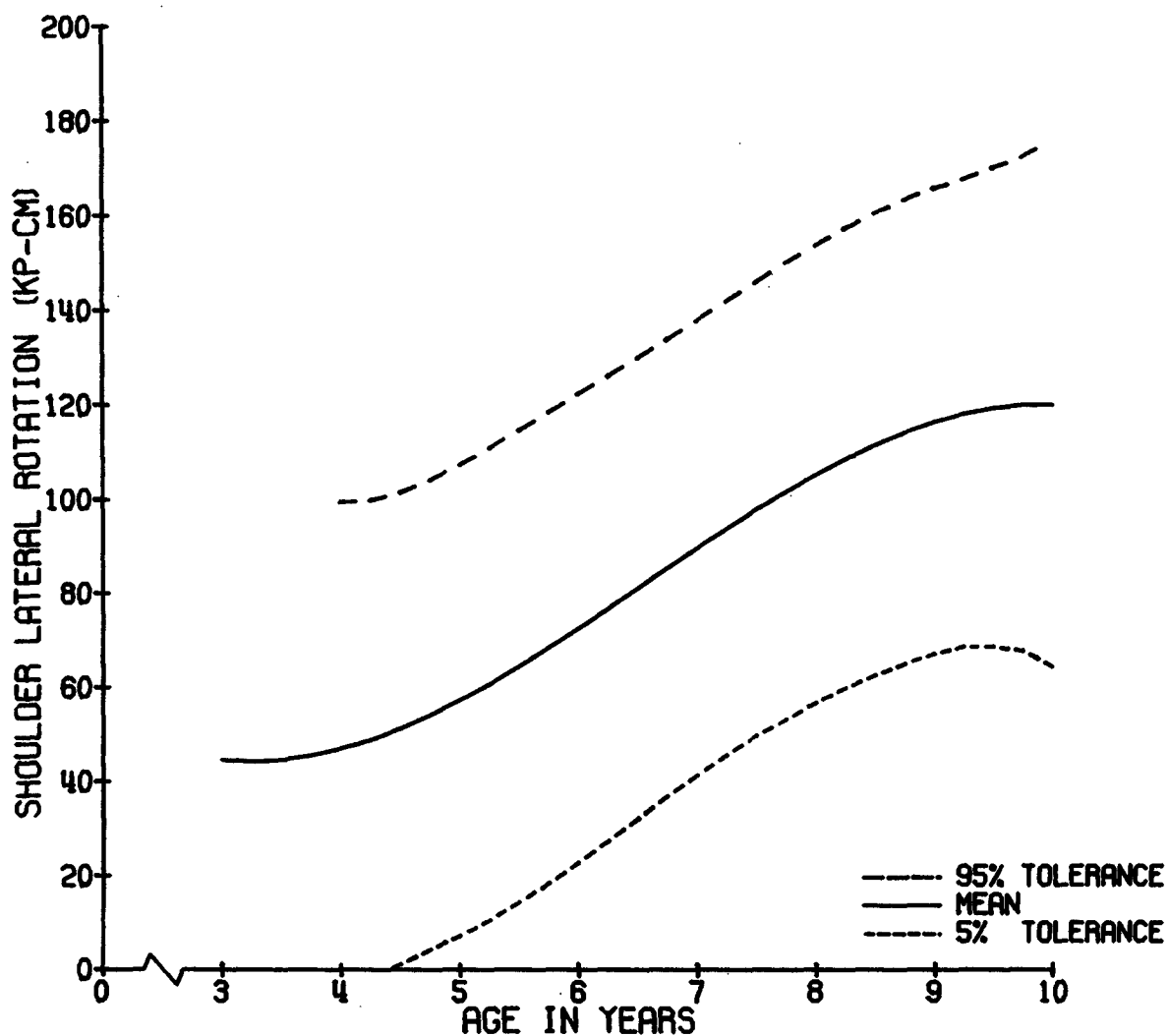

SHOULDER LATERAL ROTATION, 0 DEG. (KP-CM)

MALES

AGE	N	MEAN	ST. DEV	MIN	10%	MEDIAN	90%	MAX
3	6	43.2	13.7	16.4	16.4	44.4	56.0	56.0
4	19	50.3	20.0	18.6	25.9	53.5	78.8	80.2
5	9	67.7	31.3	26.2	26.2	56.3	113.9	113.9
6	27	75.3	22.6	43.8	52.7	71.5	98.1	156.5
7	35	96.3	25.7	52.9	61.8	93.2	136.0	149.3
8	37	114.5	30.1	71.3	80.5	106.1	161.3	195.6
9	37	131.3	31.8	74.8	95.8	124.9	174.7	210.1
10	16	130.2	35.1	50.4	92.6	131.7	176.4	193.5

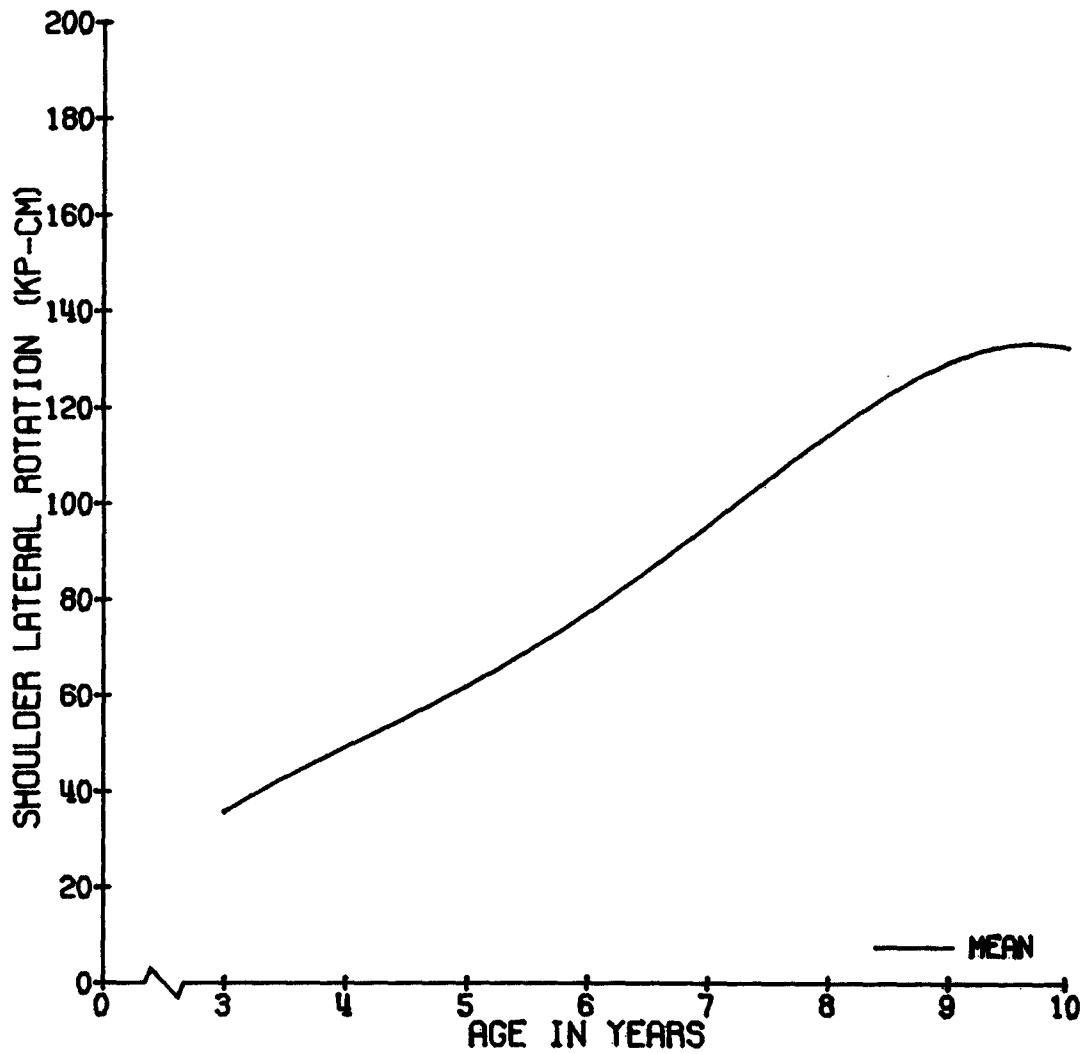

SHOULDER LATERAL ROTATION, ° DEG. (KP-CM)

FEMALES

AGE	N	MEAN	ST. DEV	MIN	10%	MEDIAN	90%	MAX
3	2	45.6	25.1	27.9	27.9	45.6	63.4	63.4
4	18	47.2	18.4	16.5	23.7	45.2	70.0	91.9
5	21	52.6	15.0	27.8	33.0	56.2	67.6	77.5
6	18	67.3	17.2	44.3	49.7	65.7	99.8	102.1
7	43	81.9	14.5	52.1	62.1	82.4	96.9	123.7
8	34	100.5	31.1	40.5	63.3	98.1	150.7	167.9
9	43	98.4	30.1	37.1	61.2	98.0	127.0	180.9
10	12	108.1	29.5	53.2	68.8	106.6	137.3	162.6

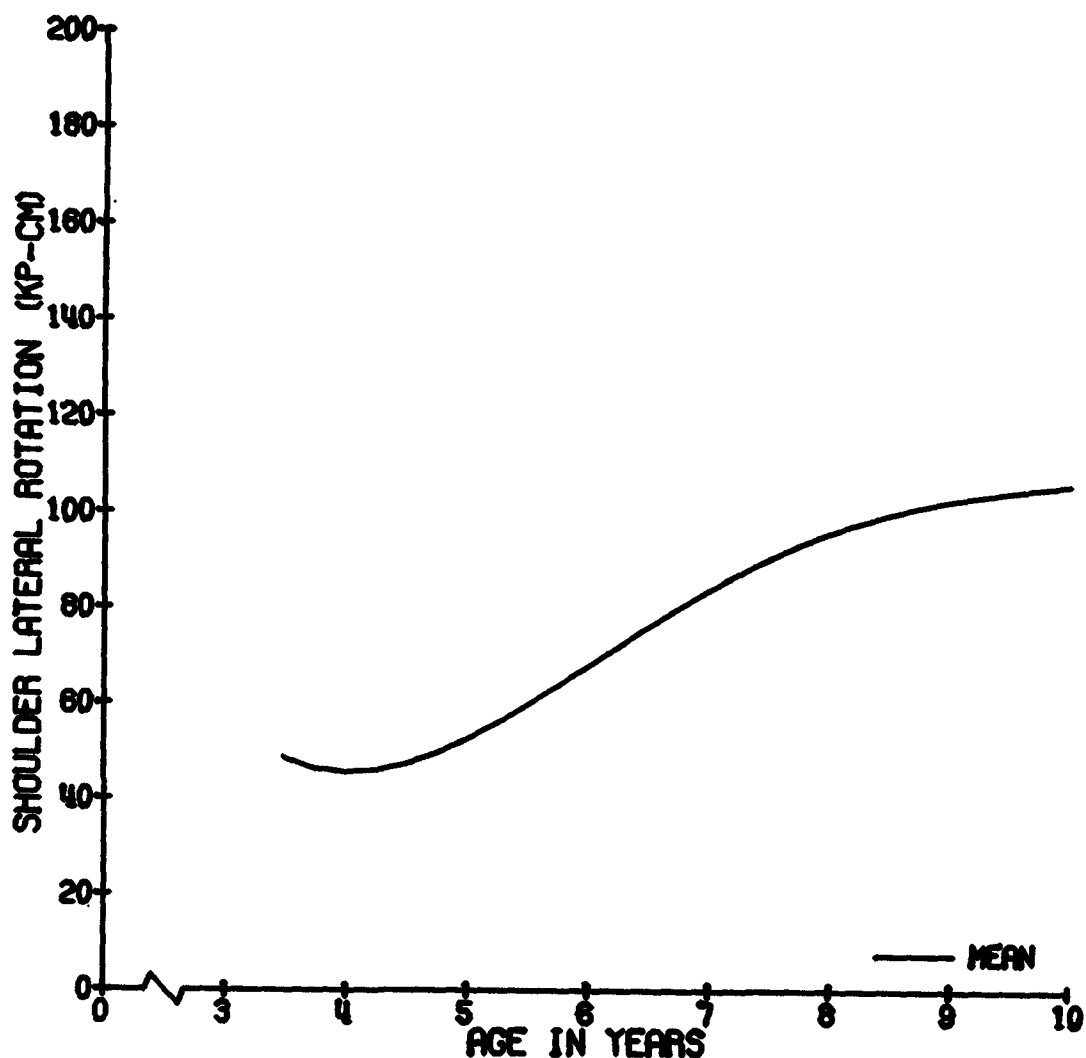

ANKLE FLEXION (DORSIFLEXION)

DESCRIPTION OF TEST: The dorsal surface of the foot is rotated superiorly at the ankle joint (tibiotarsal joint center) toward the anterior surface of the tibia.

TEST POSITION: The hip is flexed 85° , the knee flexed 90° .

ANTHROPOMETRIC MEASUREMENTS: The femoral, tibial and tarsal linkages are measured with an anthropometer.

ADJUSTMENT OF EQUIPMENT: The chair leg fixtures are set to the femoral and tibial lengths, aligning the hip, knee and ankle joint centers with those of the chair. Thin rubber pads are placed under the leg to maintain these alignments. The hip flexion angle is locked at 85° and the knee flexion angle at 90° . The chest, pelvic, knee, foot and ankle straps are then secured snugly around the hips and right leg as well as the knee strap on the left leg. The left foot is free to rest on the left foot support.

INSTRUCTIONS TO SUBJECT: The child pulls the top of his foot up and his heel down.

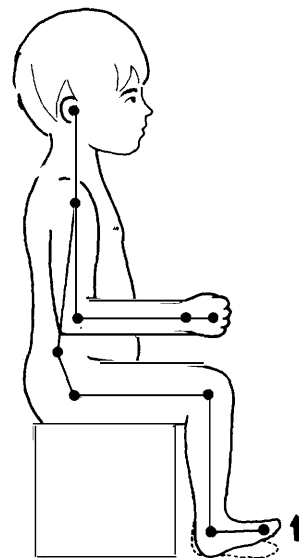
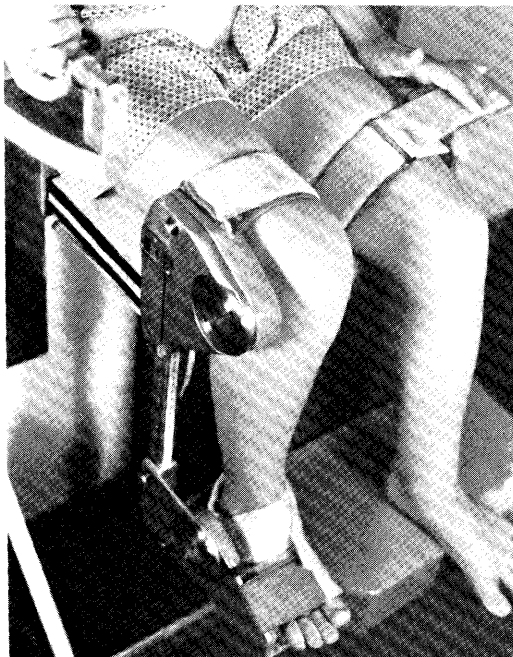

ANKLE FLEXION, 0 DEG. (KP-CM)

COMBINED SEXES

AGE	N	MEAN	ST. DEV	MIN	10%	MEDIAN	90%	MAX
3	7	26.2	5.4	17.5	17.5	28.1	33.3	33.3
4	35	29.3	12.1	13.9	17.0	25.1	47.7	54.4
5	31	37.3	13.3	15.6	21.1	36.7	55.0	68.7
6	40	56.9	16.6	19.0	35.4	56.7	77.0	88.7
7	31	75.2	22.7	38.0	44.6	77.3	107.8	118.2
8	31	96.4	32.6	34.6	62.5	91.7	133.7	199.7
9	32	122.3	31.8	60.8	81.5	119.2	163.9	188.5
10	15	120.9	31.5	61.0	90.1	120.1	161.4	182.5

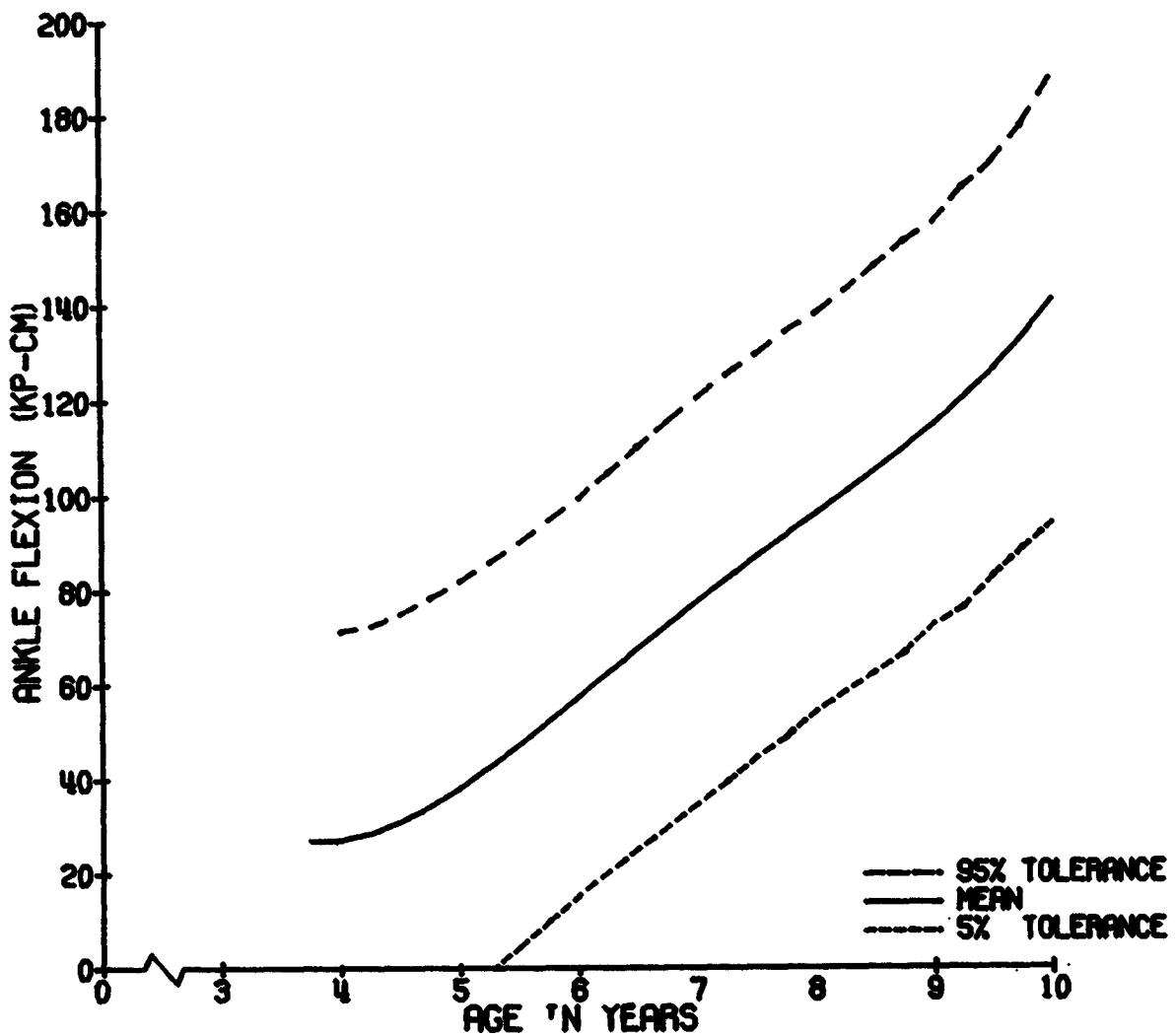

ANKLE FLEXION, 3 DEG. (KP-CM)

MALES

AGE	N	MEAN	ST. DEV	MIN	10%	MEDIAN	90%	MAX
3	5	27.6	4.5	21.5	21.5	28.1	33.3	33.3
4	17	34.8	13.5	17.3	19.4	38.8	50.8	54.4
5	10	40.3	13.5	23.5	23.5	42.6	48.5	68.7
6	26	54.3	14.9	19.0	35.4	56.5	74.9	80.0
7	14	78.2	21.3	42.5	52.6	82.1	98.4	113.8
8	19	101.1	37.8	34.6	56.5	93.3	157.3	199.7
9	13	140.2	28.4	99.5	100.1	137.0	175.2	188.5
10	7	129.7	24.8	90.1	90.1	127.3	161.4	161.4

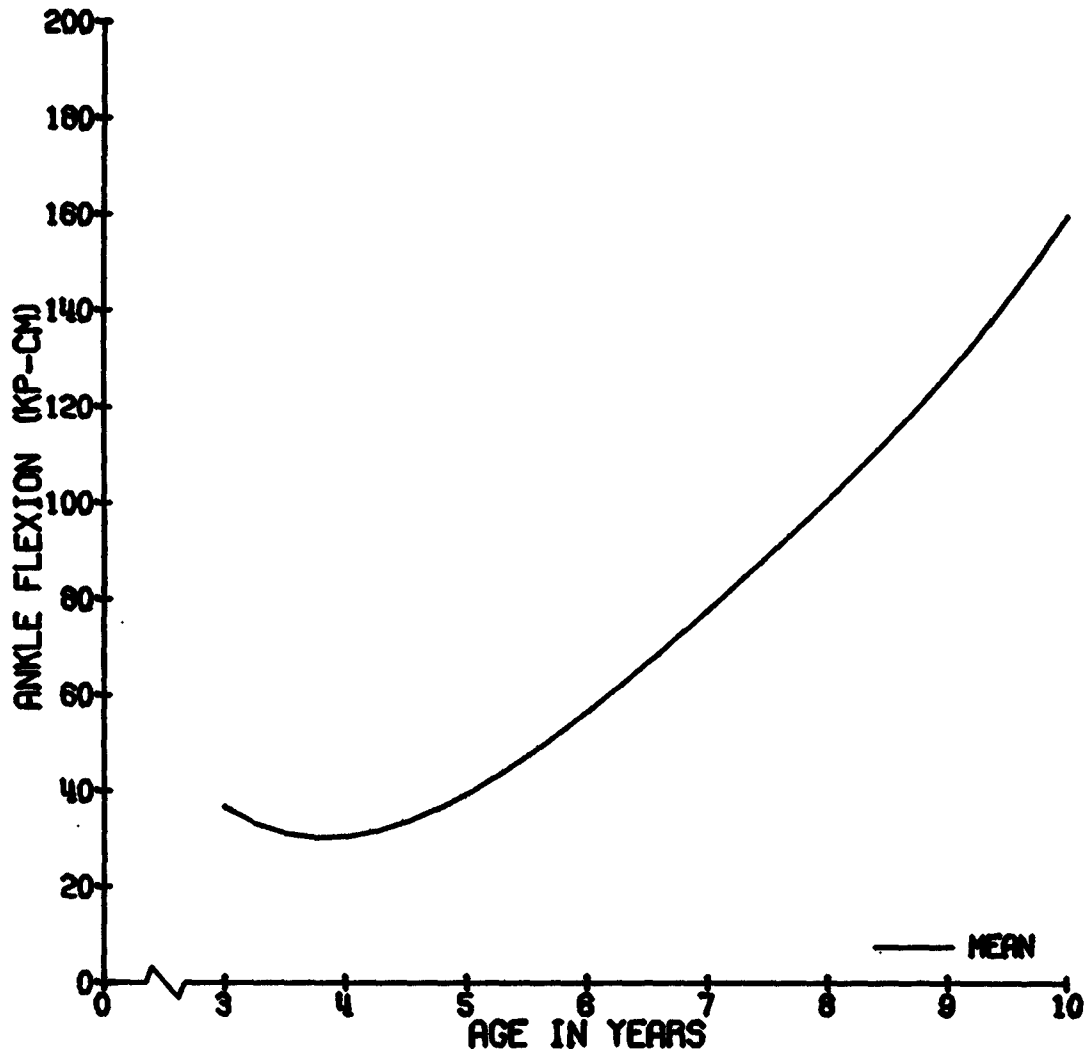

ANKLE FLEXION, 0 DEG. (KP-CM)

FEMALES

AGE	N	MEAN	ST. DEV	MIN	10%	MEDIAN	90%	MAX
3	2	22.9	7.7	17.5	17.5	22.9	28.4	28.4
4	18	25.1	8.5	13.9	15.2	23.7	40.0	42.6
5	21	35.8	13.3	15.6	17.7	35.1	55.0	61.9
6	14	61.9	19.0	28.6	42.1	65.3	85.8	88.7
7	17	72.7	24.1	38.0	40.5	70.5	108.8	118.2
8	12	88.9	21.5	57.1	62.5	89.8	117.8	125.3
9	19	110.1	28.5	60.8	64.7	111.5	151.2	160.4
10	8	113.2	36.2	61.0	61.0	106.5	182.5	182.5

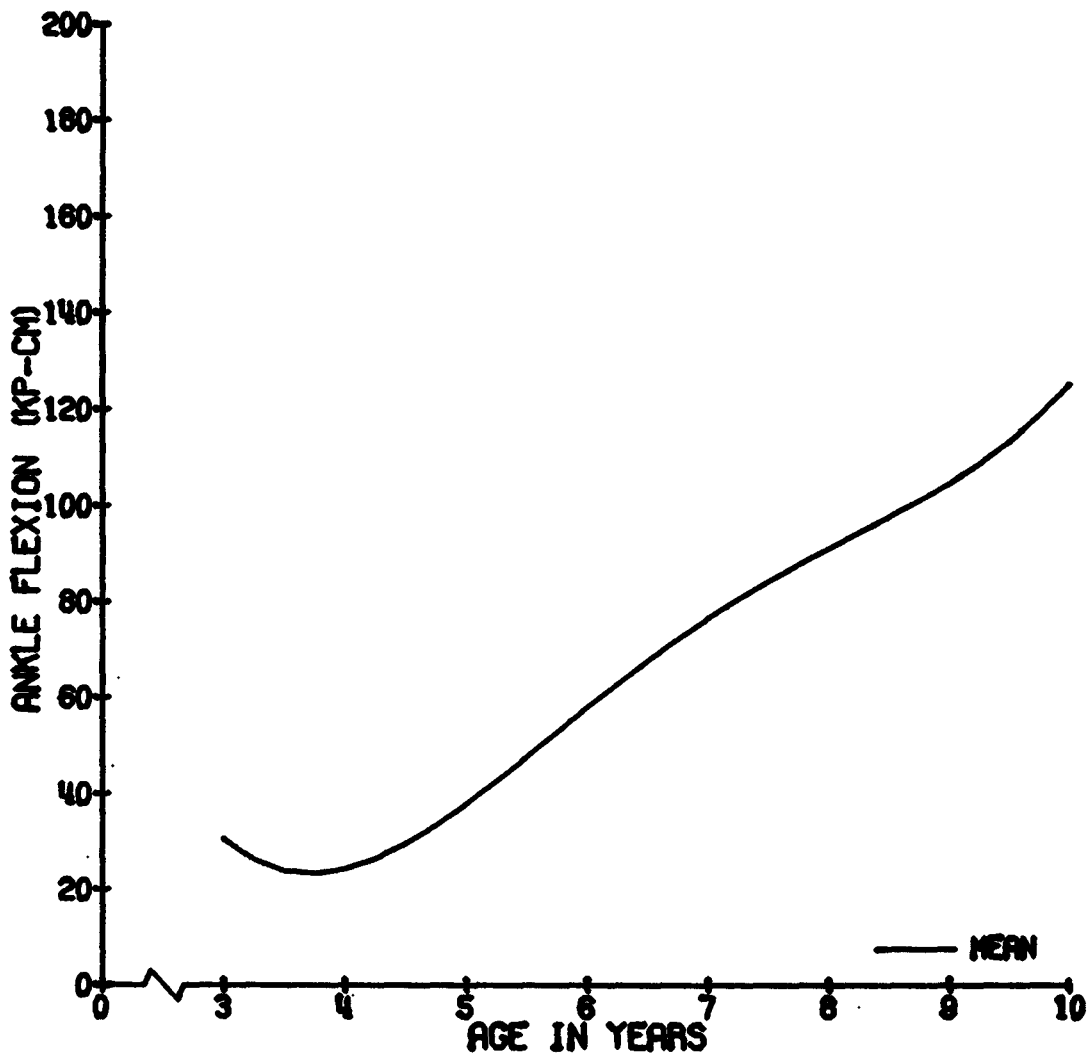

ANKLE EXTENSION (PLANTAR FLEXION)

DESCRIPTION OF TEST: The plantar surface of the foot is rotated inferiorly at the ankle joint (tibiotarsal joint center) away from the anterior surface of the tibia.

TEST POSITION: The hip is flexed 85° , the knee flexed 90° .

ANTHROPOMETRIC MEASUREMENTS: The femoral, tibial and tarsal linkages are measured with an anthropometer.

ADJUSTMENT OF EQUIPMENT: The chair leg fixtures are set to the femoral and tibial lengths, aligning the hip, knee and ankle joint centers with those of the chair. Thin rubber pads are placed under the leg to maintain these alignments. The hip flexion angle is locked at 85° and the knee flexion angle at 90° . The chest, pelvic, knee, foot and ankle straps are then secured snugly around the hips and right leg as well as the knee strap on the left leg. The left foot is free to rest on the left foot support.

INSTRUCTIONS TO SUBJECT: The child pushes his toes down and his heel up.

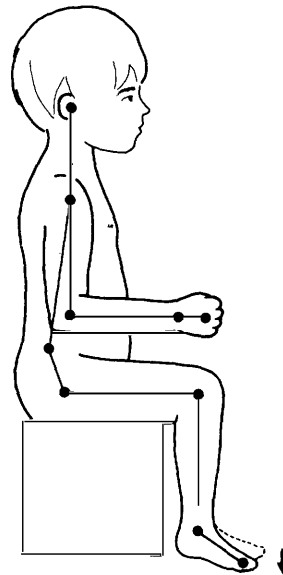

ANKLE EXTENSION,) DEG. (KP-CM)

COMBINED SEXES

AGE	N	MEAN	ST. DEV	MIN	10%	MEDIAN	90%	MAX
3	7	77.6	27.3	24.9	24.9	93.5	97.6	97.6
4	36	100.9	58.3	18.6	34.7	101.9	200.1	281.7
5	31	107.9	68.7	23.5	34.1	98.1	164.6	326.1
6	41	149.1	73.0	10.8	71.0	141.6	238.0	345.4
7	31	175.5	77.5	27.7	56.6	196.1	256.5	306.0
8	31	215.4	84.6	89.6	112.8	208.1	330.6	342.1
9	32	284.5	72.8	137.5	178.8	313.3	342.7	439.4
10	15	296.7	70.1	154.3	173.6	325.0	342.9	426.6

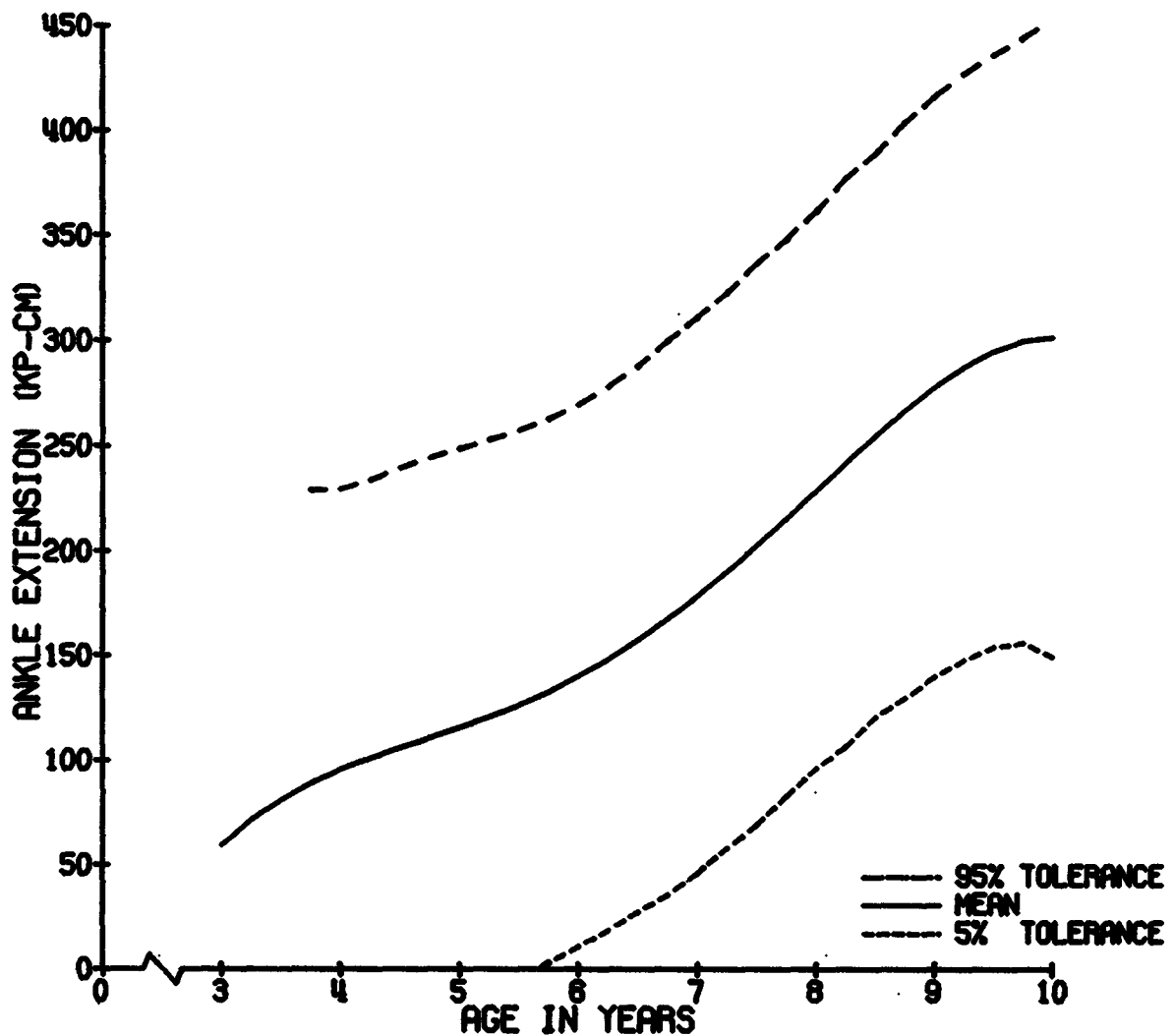

ANKLE EXTENSION,) DEG. (KP-CM)

MALES

AGE	N	MEAN	ST. DEV	MIN	10%	MEDIAN	90%	MAX
3	5	71.0	30.5	24.9	24.9	82.9	97.6	97.6
4	18	108.6	38.3	34.7	54.7	109.8	143.3	207.6
5	10	124.0	86.4	32.5	32.5	126.4	163.9	326.1
6	26	143.3	68.6	10.8	61.8	138.7	218.4	345.4
7	14	170.0	76.8	33.9	65.7	183.7	267.0	295.0
8	19	208.1	71.4	112.8	118.2	208.1	328.8	330.2
9	13	323.1	55.9	195.5	236.9	329.7	345.4	439.4
10	7	343.5	38.1	310.3	310.3	334.1	426.6	426.6

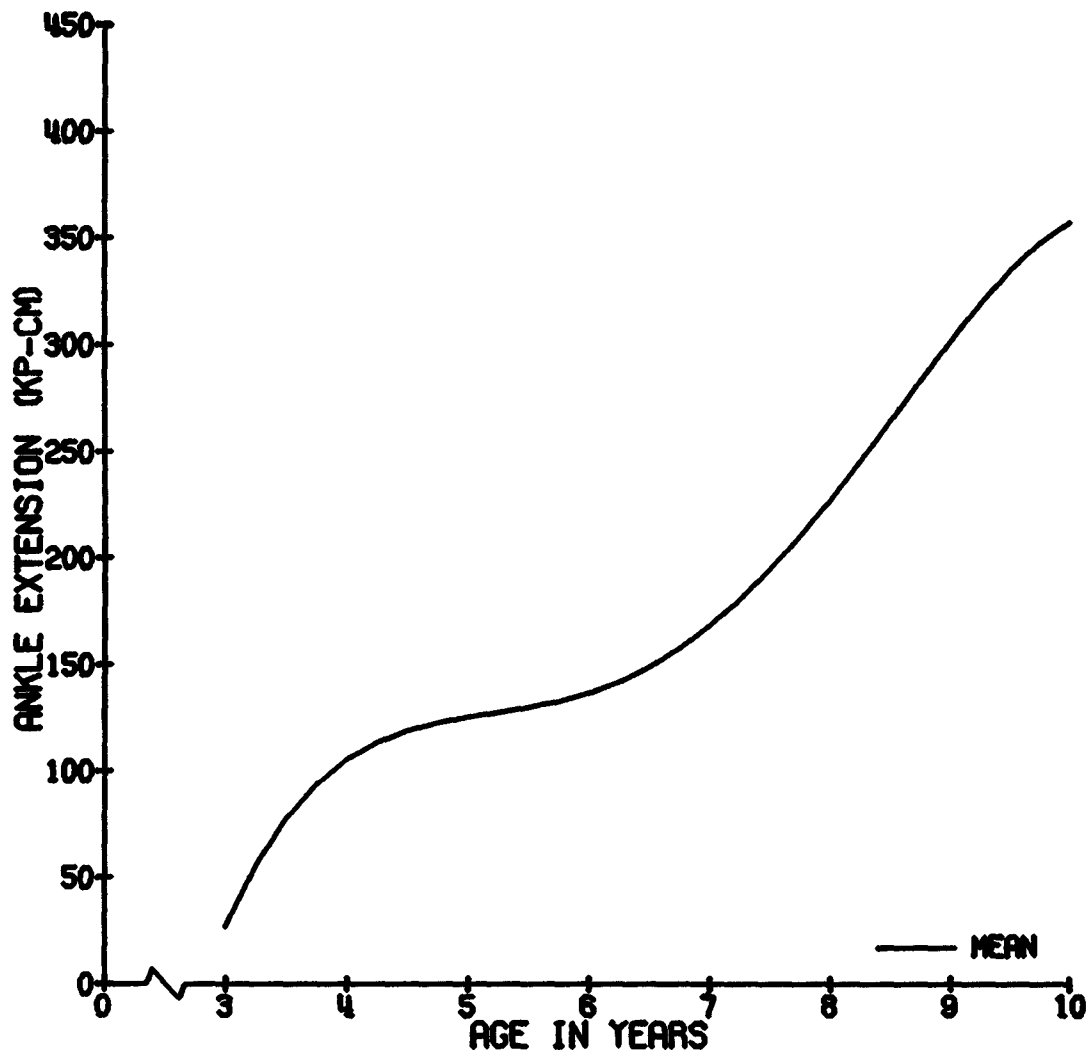

ANKLE EXTENSION, ° DEG. (KP-CM)

FEMALES

AGE	N	MEAN	ST. DEV	MIN	10%	MEDIAN	90%	MAX
3	2	94.1	0.8	93.5	93.5	94.1	94.7	94.7
4	18	93.2	73.6	18.6	29.8	63.1	217.7	281.7
5	21	100.3	59.3	23.5	34.1	87.2	164.6	226.6
6	15	159.3	81.6	51.1	73.3	149.3	293.2	325.9
7	17	179.3	80.2	27.7	49.0	209.2	256.5	306.0
8	12	227.0	104.7	89.6	110.0	219.1	338.3	342.1
9	19	258.3	71.7	137.5	140.6	294.2	334.6	340.0
10	8	255.3	66.9	154.3	154.3	267.1	330.1	330.1

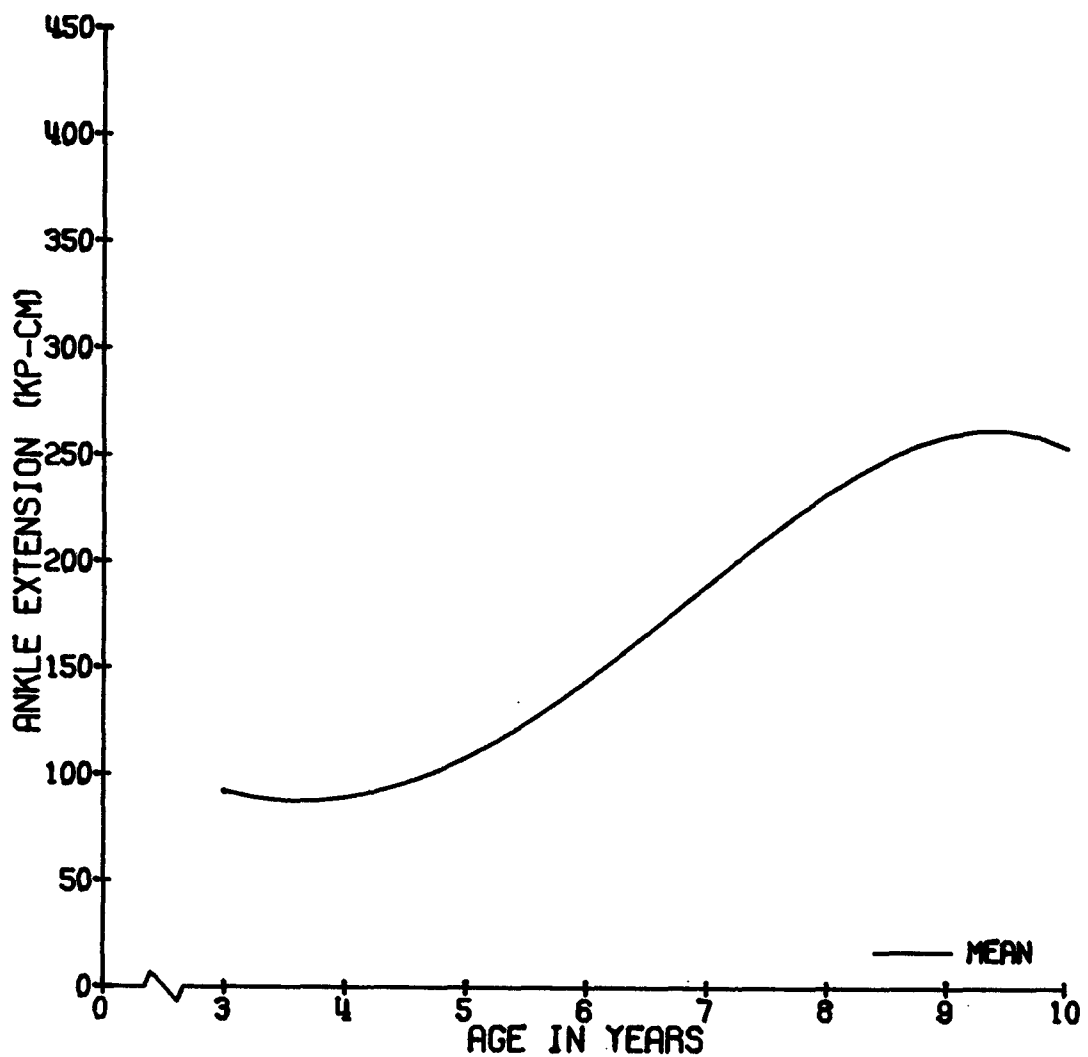

KNEE FLEXION

DESCRIPTION OF TEST: The tibia and fibula are rotated posteriorly at the knee joint (femorotibial joint center) in the sagittal plane.

TEST POSITION: The hip is flexed 85° , the knee flexed 90° .

ANTHROPOMETRIC MEASUREMENTS: The femoral, tibial and tarsal linkages are measured with an anthropometer.

ADJUSTMENT OF EQUIPMENT: The chair leg fixtures are set to the femoral and tibial lengths, aligning the hip, knee and ankle joint centers with those of the chair. Thin rubber pads are placed under the leg to maintain these alignments. The hip flexion angle is locked at 85° and the knee flexion angle at 90° . The chest, pelvic, knee, foot and ankle straps are then secured snugly around the hips and right leg as well as the knee strap on the left leg. The left foot is free to rest on the left foot support.

INSTRUCTIONS TO SUBJECT: The child pulls his foot backward.

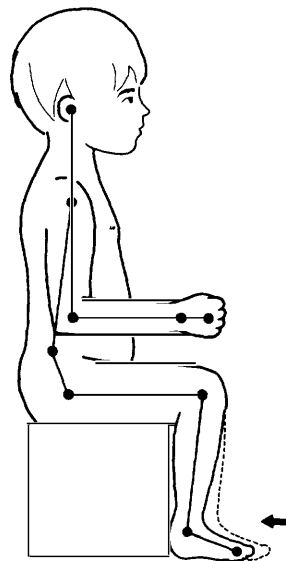

KNEE FLEXION, 90 DEG. (KP-CM)

COMBINED SEXES

AGE	N	MEAN	ST. DEV	MIN	10%	MEDIAN	90%	MAX
3	7	51.0	20.1	27.5	27.5	52.9	81.7	81.7
4	48	47.7	19.8	17.7	23.3	43.2	76.4	99.4
5	49	72.0	35.8	20.9	29.0	67.8	115.1	163.8
6	54	97.4	39.3	14.4	47.2	97.4	147.3	206.2
7	31	119.8	34.0	32.3	70.7	114.8	155.1	182.3
8	31	139.7	57.5	47.4	84.6	131.9	194.5	322.0
9	32	202.4	64.7	78.6	125.3	216.0	276.9	357.9
10	15	212.4	35.8	77.1	95.6	204.8	315.6	373.8

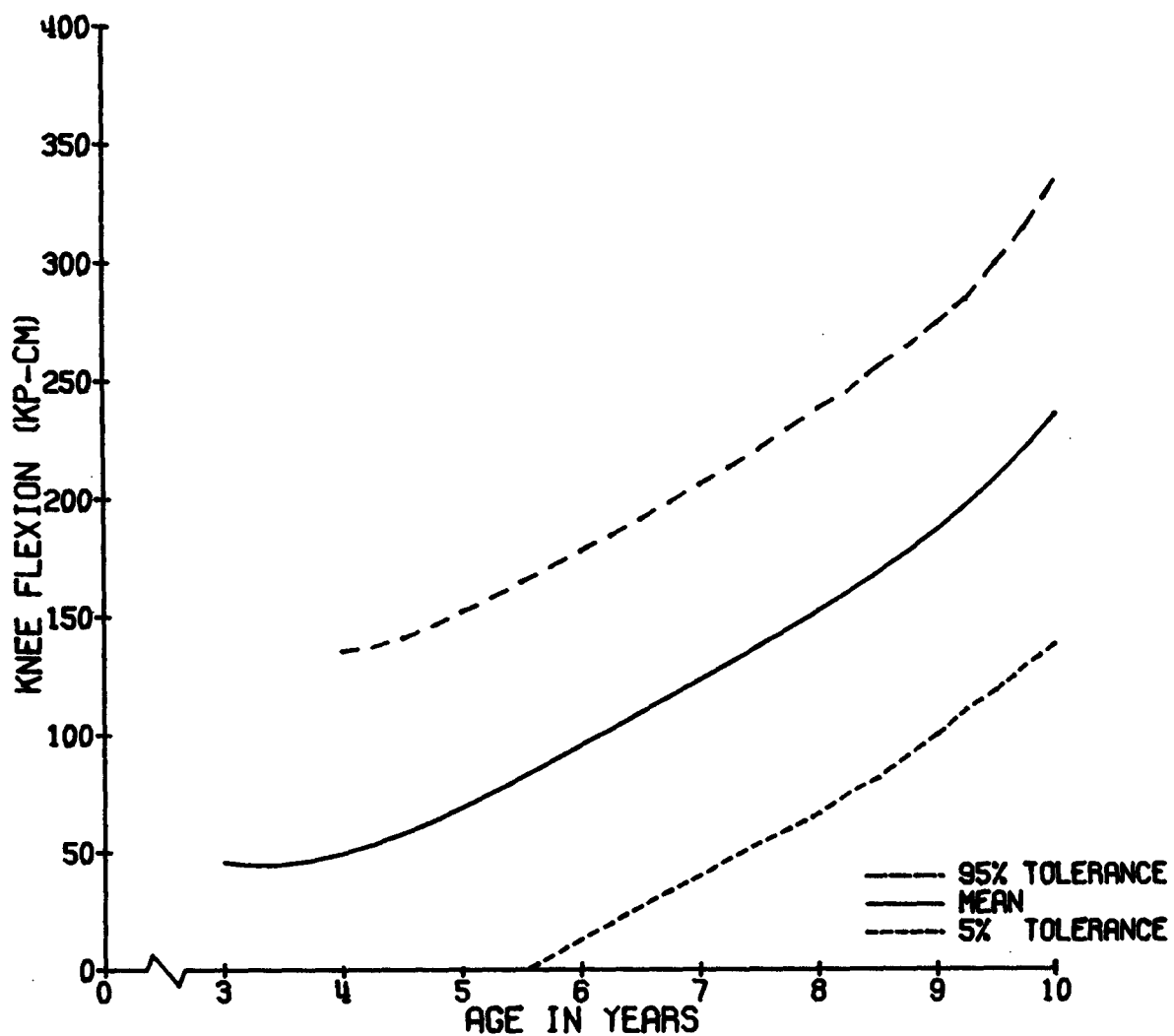

KNEE FLEXION, 90 DEG. (KP-CM)

MALES

AGE	N	MEAN	ST. DEV	MIN	10%	MEDIAN	90%	MAX
3	5	49.5	15.4	27.5	27.5	52.9	65.6	65.6
4	23	51.8	18.9	18.0	33.8	47.5	78.0	85.9
5	18	82.2	44.2	20.9	22.8	84.3	160.6	163.8
6	32	93.2	39.5	14.4	47.2	90.7	147.3	164.1
7	14	122.4	41.7	32.3	70.7	115.8	171.6	182.3
8	19	129.8	45.5	47.4	68.4	132.6	194.5	217.3
9	13	228.0	57.1	116.8	127.2	233.5	282.8	300.4
10	7	241.7	80.5	153.5	153.5	216.4	373.8	373.8

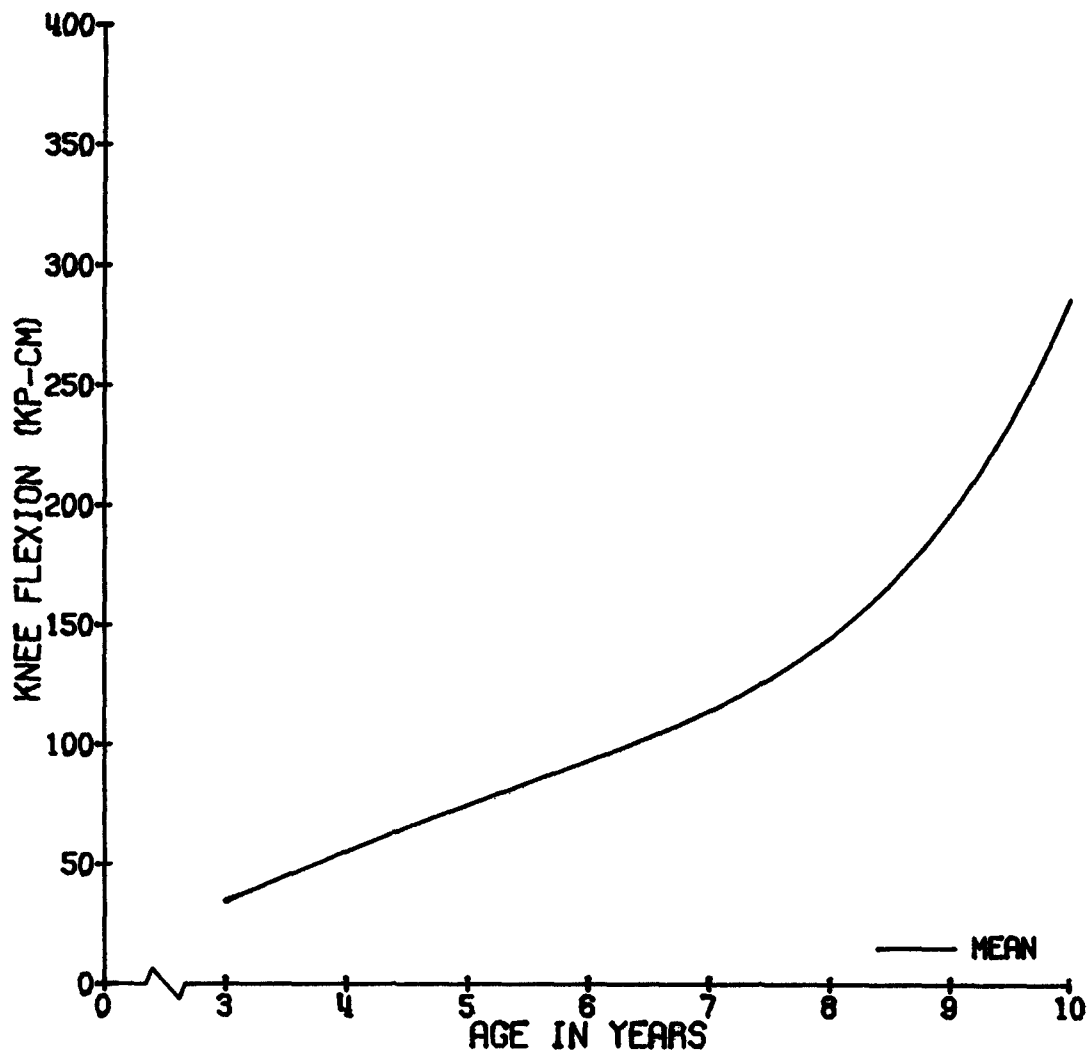

KNEE FLEXION, 90 DEG. (KP-CM)

FEMALES

AGE	N	MEAN	ST. DEV	MIN	10%	MEDIAN	90%	MAX
3	2	54.8	38.0	28.0	28.0	54.8	81.7	81.7
4	25	43.9	20.2	17.7	21.7	41.4	69.5	99.4
5	31	66.0	28.9	21.0	31.3	64.9	98.7	144.2
6	22	103.5	39.2	34.4	66.5	98.3	142.7	206.2
7	17	117.7	27.2	64.1	70.3	114.8	151.7	155.1
8	12	155.5	72.0	86.4	89.2	129.4	273.6	322.0
9	19	184.9	65.1	78.6	106.2	173.6	247.1	357.9
10	3	186.7	87.0	77.1	77.1	179.2	315.6	315.6

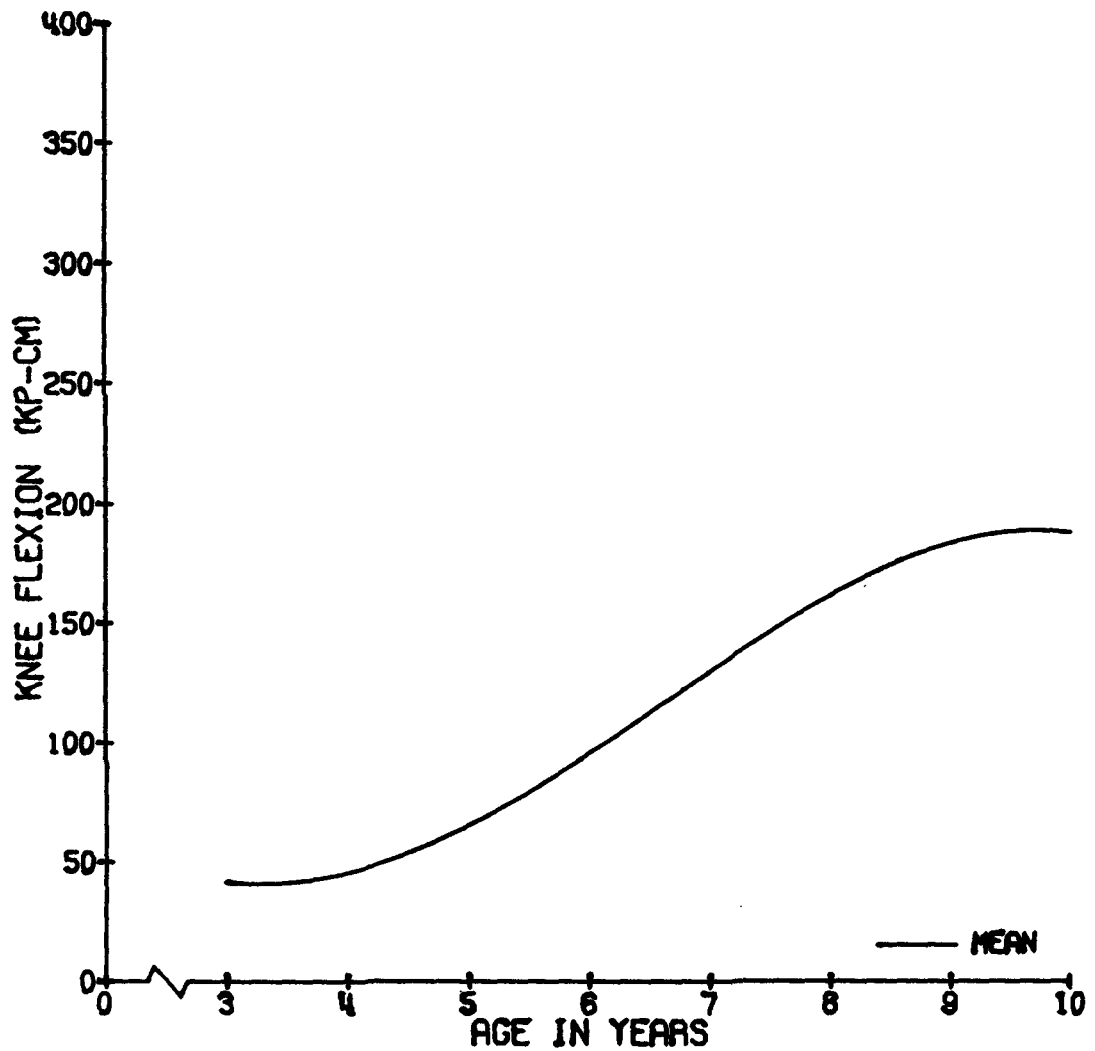

KNEE EXTENSION

DESCRIPTION OF TEST: The tibia and fibula are rotated anteriorly at the knee joint (femorotibial joint center) in the sagittal plane.

TEST POSITION: The hip is flexed 85° , the knee flexed 90° .

ANTHROPOMETRIC MEASUREMENTS: The femoral, tibial and tarsal linkages are measured with an anthropometer.

ADJUSTMENT OF EQUIPMENT: The chair leg fixtures are set to the femoral and tibial lengths, aligning the hip, knee and ankle joint centers with those of the chair. Thin rubber pads are placed under the leg to maintain these alignments. The hip flexion angle is locked at 85° and the knee flexion angle at 90° . The chest, pelvic, knee, foot and ankle straps are then secured snugly around the hips and right leg as well as the knee strap on the left leg. The left foot is free to rest on the left foot support.

INSTRUCTIONS TO SUBJECT: The child pushes his foot forward.

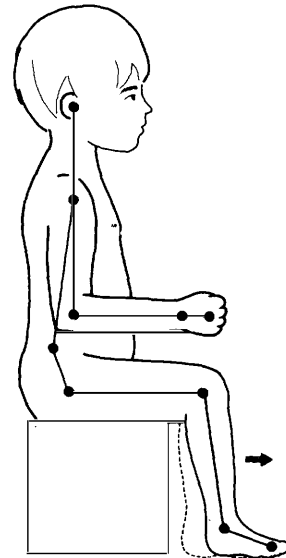
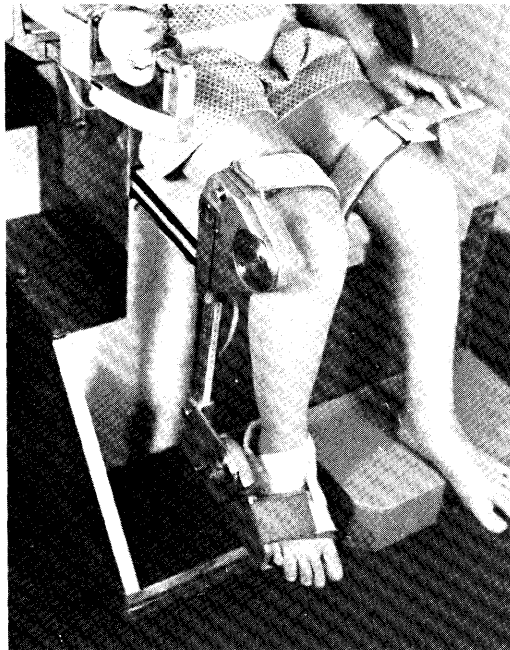

KNEE EXTENSION, 90 DEG. (KP-CM)

COMBINED SEXES

AGE	N	MEAN	ST. DEV	MIN	10%	MEDIAN	90%	MAX
3	12	170.5	62.8	60.0	106.5	160.3	246.4	296.4
4	74	190.2	72.4	57.2	98.6	182.4	291.7	408.1
5	81	234.5	75.2	85.2	139.1	232.7	342.2	404.5
6	70	277.0	98.0	114.9	142.5	274.2	412.5	572.8
7	79	386.1	118.8	111.6	241.1	369.2	568.2	727.6
8	71	485.4	141.8	203.6	278.9	483.1	662.2	794.9
9	81	575.7	141.3	238.6	399.1	585.2	733.7	870.3
10	28	566.1	186.1	150.6	359.9	583.8	764.1	867.5

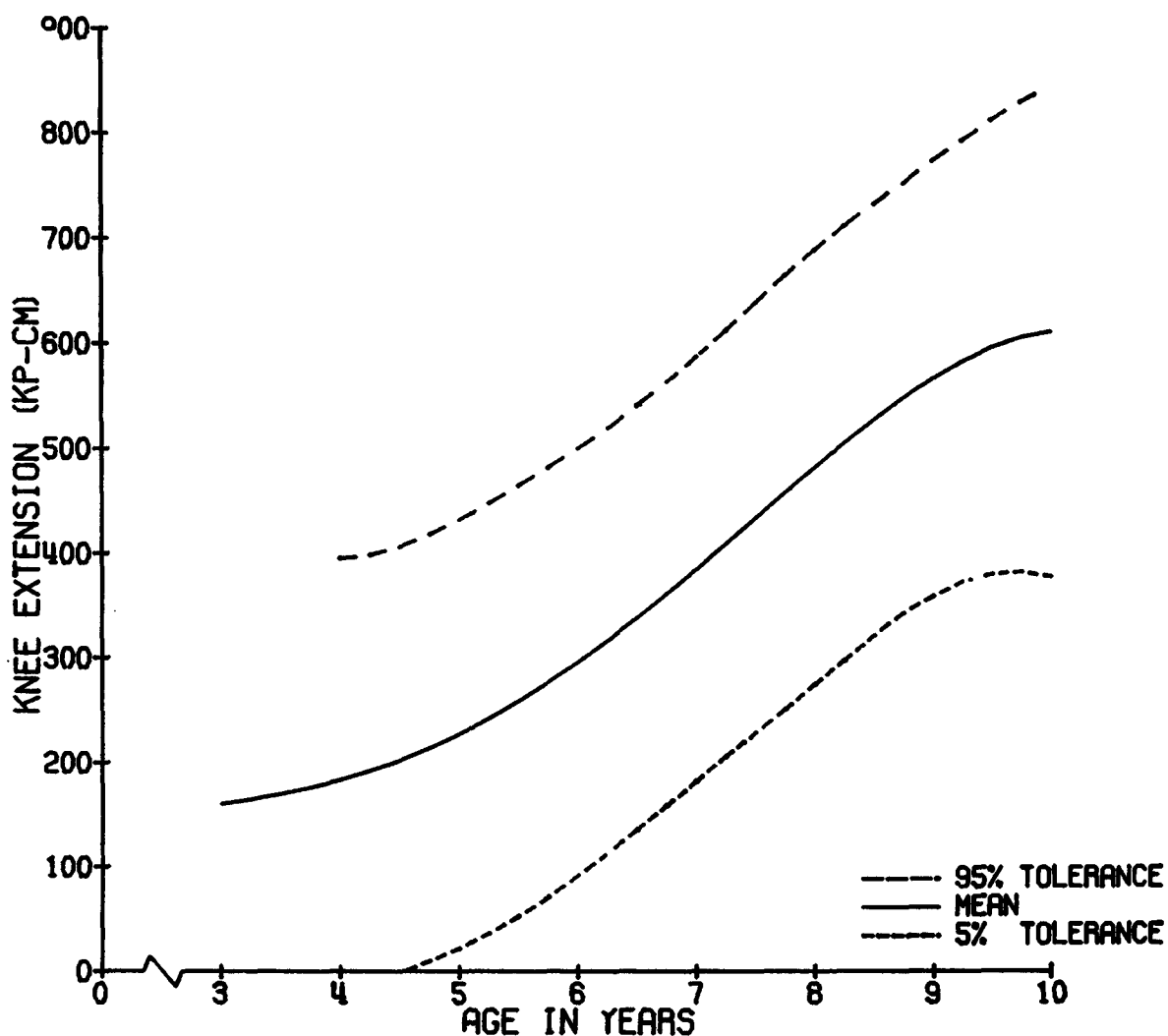

KNEE EXTENSION, 90 DEG. (KP-CM)

MALES

AGE	N	MEAN	ST. DEV	MIN	10%	MEDIAN	90%	MAX
3	8	183.6	72.8	60.0	60.0	169.5	296.4	296.4
4	32	207.6	74.5	69.7	139.9	202.9	302.3	408.1
5	32	230.9	71.4	85.2	131.1	239.3	321.4	351.4
6	38	285.5	95.1	127.9	153.8	262.8	412.5	572.8
7	36	388.3	120.3	111.6	241.1	375.3	568.2	593.1
8	37	437.5	133.3	203.6	274.0	441.8	655.8	731.4
9	38	623.6	122.9	380.9	433.9	630.9	770.2	870.3
10	16	603.4	212.1	150.6	173.1	670.4	795.5	867.5

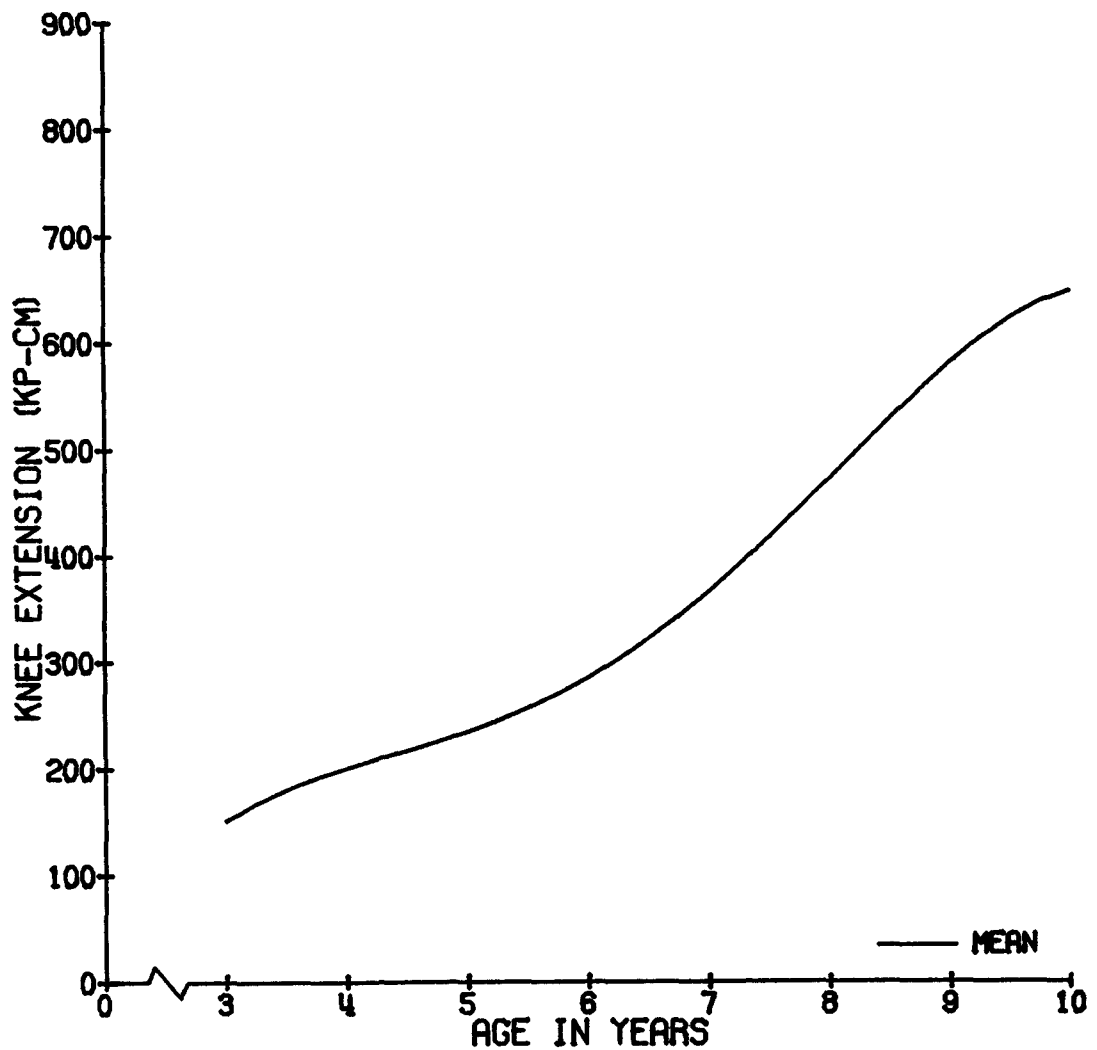

KNEE EXTENSION, 9) DEG. (KP-CM)

FEMALES

AGE	N	MEAN	ST. DEV	MIN	10%	MEDIAN	90%	MAX
3	4	144.2	26.6	106.5	106.5	153.0	164.3	164.3
4	42	176.9	68.7	57.2	74.9	175.0	260.1	319.7
5	49	236.9	78.3	86.5	139.1	227.3	346.0	404.5
6	32	268.9	102.0	114.9	142.5	240.6	413.1	464.5
7	43	384.3	119.0	182.2	269.0	368.9	552.1	727.6
8	34	537.7	133.8	254.4	406.5	528.2	735.2	794.9
9	43	533.4	144.3	238.6	295.7	560.8	702.4	803.6
10	12	516.5	137.8	359.9	368.5	481.6	726.6	735.5

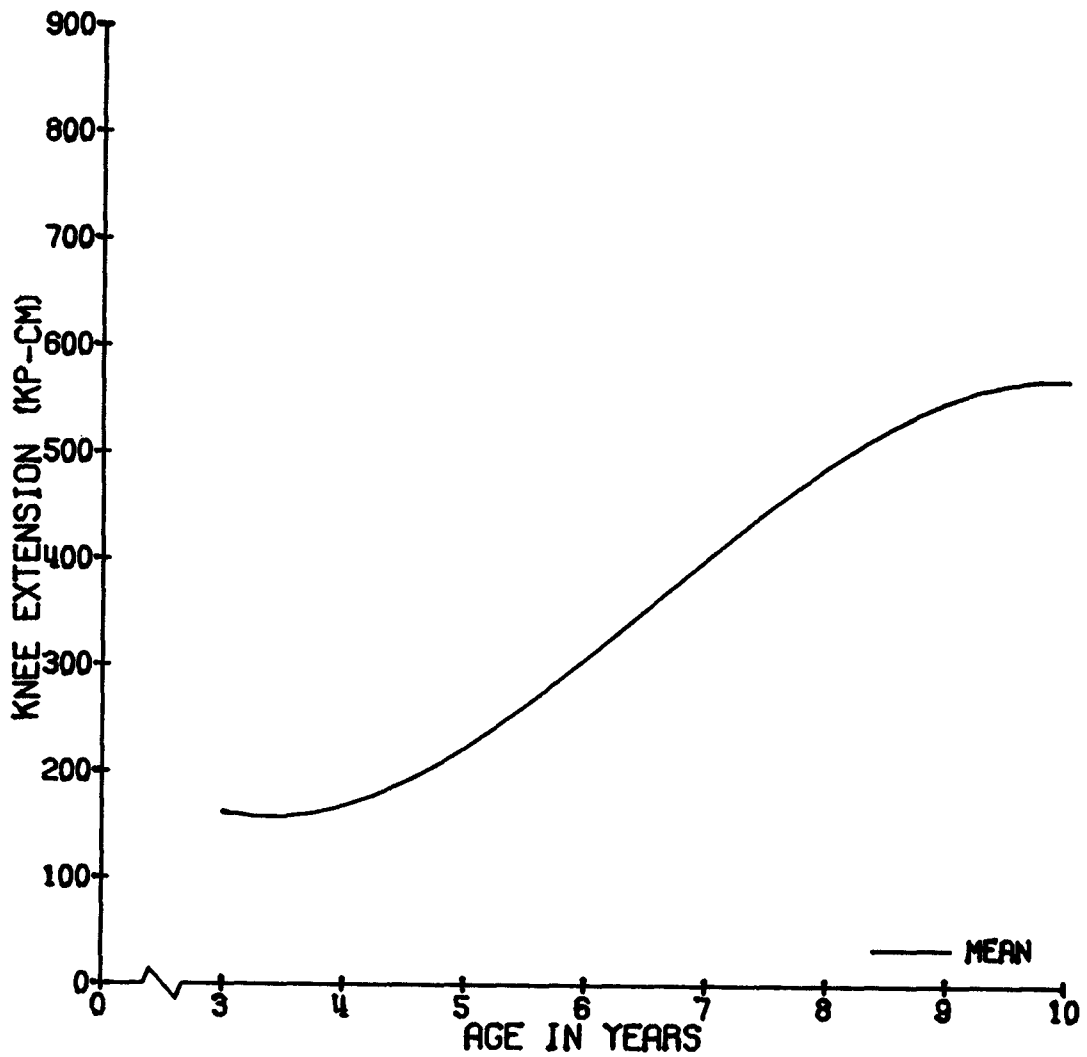

KNEE MEDIAL ROTATION

DESCRIPTION OF TEST: (for flexed knee only) The tibia and fibula are rotated at the knee joint (femorotibial joint center) moving the anterior surface of the tibia medially toward the midline of the body.

TEST POSITION: The hip is flexed 85° , the knee flexed 90° .

ANTHROPOMETRIC MEASUREMENTS: The femoral, tibial and tarsal linkages are measured with an anthropometer.

ADJUSTMENT OF EQUIPMENT: The chair leg fixtures are set to the femoral and tibial lengths, aligning the hip, knee and ankle joint centers with those of the chair. Thin rubber pads are placed under the leg to maintain these alignments. The hip flexion angle is locked at 85° and the knee flexion angle at 90° . The chest, pelvic, knee, foot and ankle straps are then secured snugly around the hips and right leg as well as the knee strap on the left leg. The left foot is free to rest on the left foot support.

INSTRUCTIONS TO SUBJECT: The child pulls his toes to his left and his heel to his right.

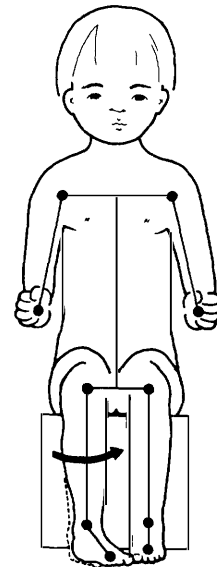
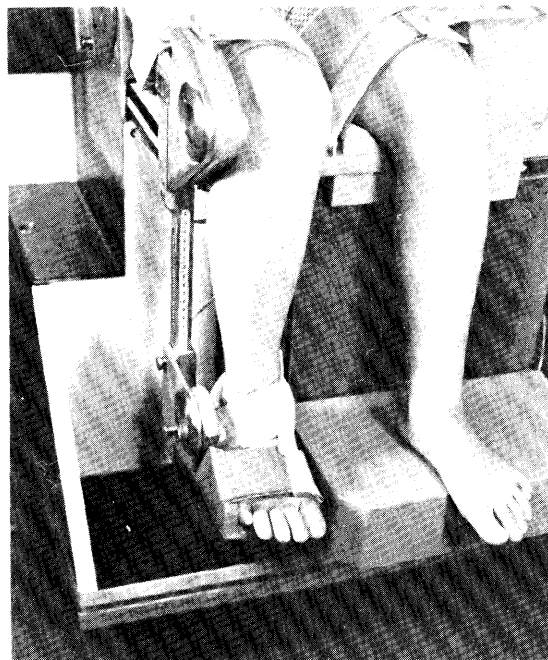

KNEE MEDIAL ROTATION, 0 DEG. (KP-CM)

COMBINED SEXES

AGE	N	MEAN	ST. DEV	MIN	10%	MEDIAN	90%	MAX
3	8	14.2	4.1	6.9	6.9	15.4	19.7	19.7
4	37	16.2	7.2	2.8	8.0	15.5	26.4	33.1
5	30	18.7	7.5	5.2	8.6	17.9	28.8	36.2
6	42	28.9	9.0	14.5	19.0	27.9	42.8	52.5
7	31	37.7	11.4	17.9	26.5	37.0	48.9	77.5
8	31	48.2	14.4	27.9	32.8	48.7	66.8	79.5
9	32	61.2	20.2	32.9	39.6	57.8	90.7	110.3
10	15	69.7	19.3	33.6	47.3	69.9	90.9	115.2

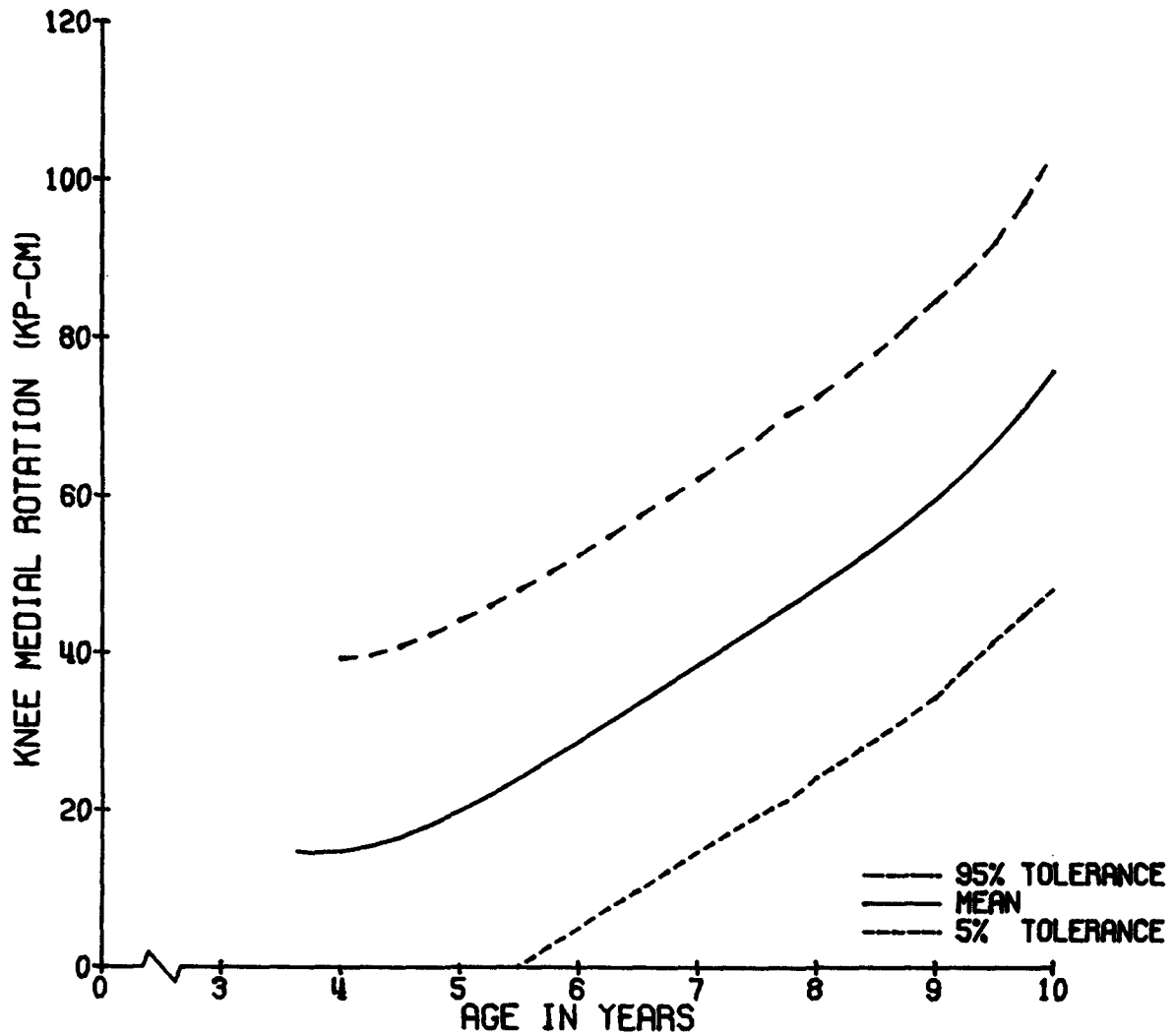

KNEE MEDIAL ROTATION, 0 DEG. (KP-CM)

MALES

AGE	N	MEAN	ST. DEV	MIN	10%	MEDIAN	90%	MAX
3	6	14.3	4.5	6.9	6.9	15.5	19.7	19.7
4	19	17.6	7.7	5.8	8.0	17.2	30.7	33.1
5	9	19.3	9.3	5.2	5.2	13.4	30.8	30.8
6	26	26.9	8.9	14.5	17.8	23.8	42.8	46.4
7	14	38.2	14.3	17.9	20.9	38.6	48.3	77.5
8	19	48.8	15.9	29.0	33.2	41.6	78.5	79.5
9	13	69.8	21.4	46.3	47.5	69.4	102.4	110.3
10	7	79.1	18.1	61.0	61.0	75.5	115.2	115.2

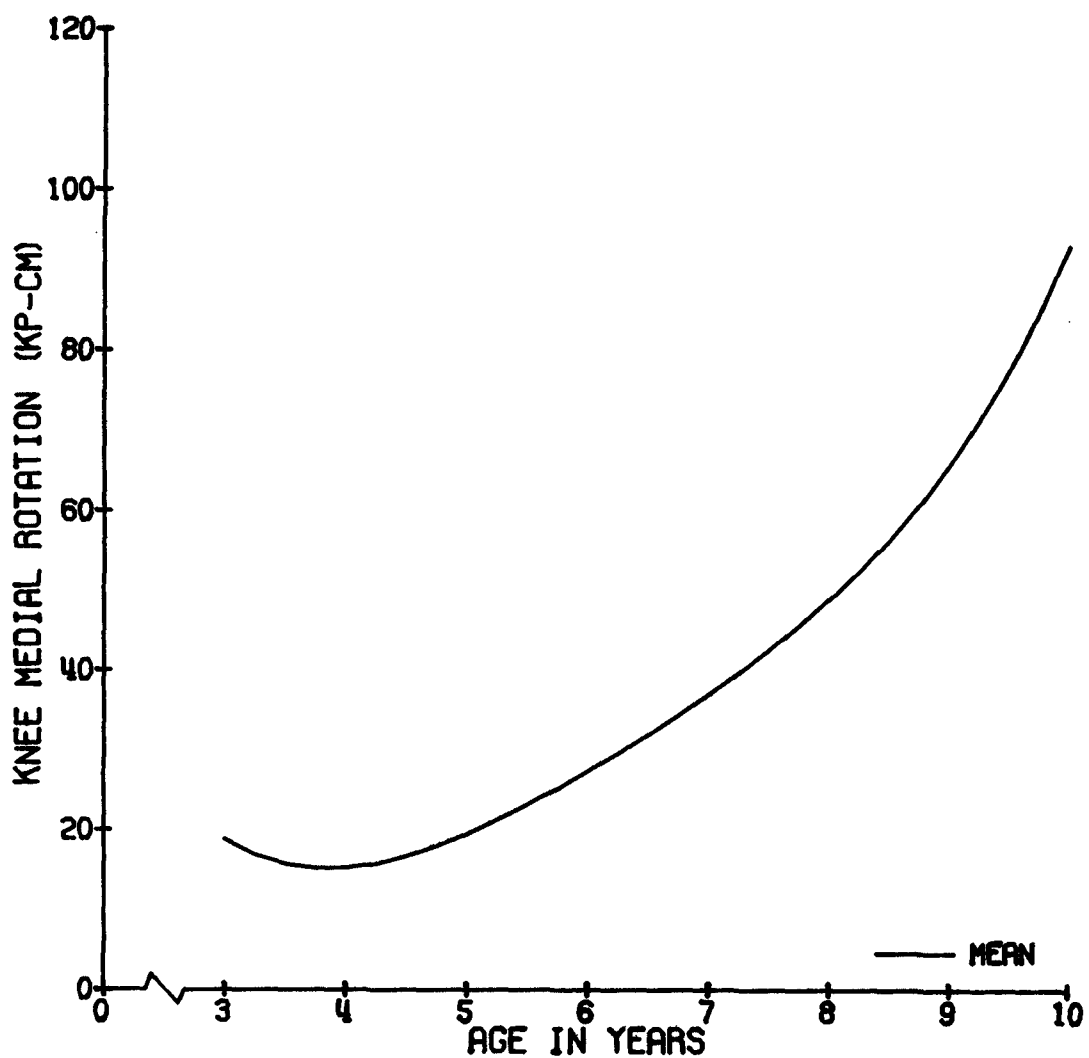

KNEE MEDIAL ROTATION, 0 DEG. (KP-CM)

FEMALES

AGE	N	MEAN	ST. DEV	MIN	10%	MEDIAN	90%	MAX
3	2	13.7	3.8	11.0	11.0	13.7	16.4	16.4
4	18	14.7	6.4	2.8	5.3	13.7	23.2	26.4
5	21	18.9	6.8	8.0	11.9	18.4	28.3	36.2
6	16	32.1	8.5	17.7	23.5	30.8	44.5	52.5
7	17	37.3	8.8	26.2	28.8	35.5	52.5	52.8
8	12	47.3	12.2	27.9	29.1	50.5	55.7	70.0
9	19	55.4	17.5	32.9	35.4	52.5	89.6	90.7
10	8	61.5	17.4	33.6	33.6	64.5	90.9	90.9

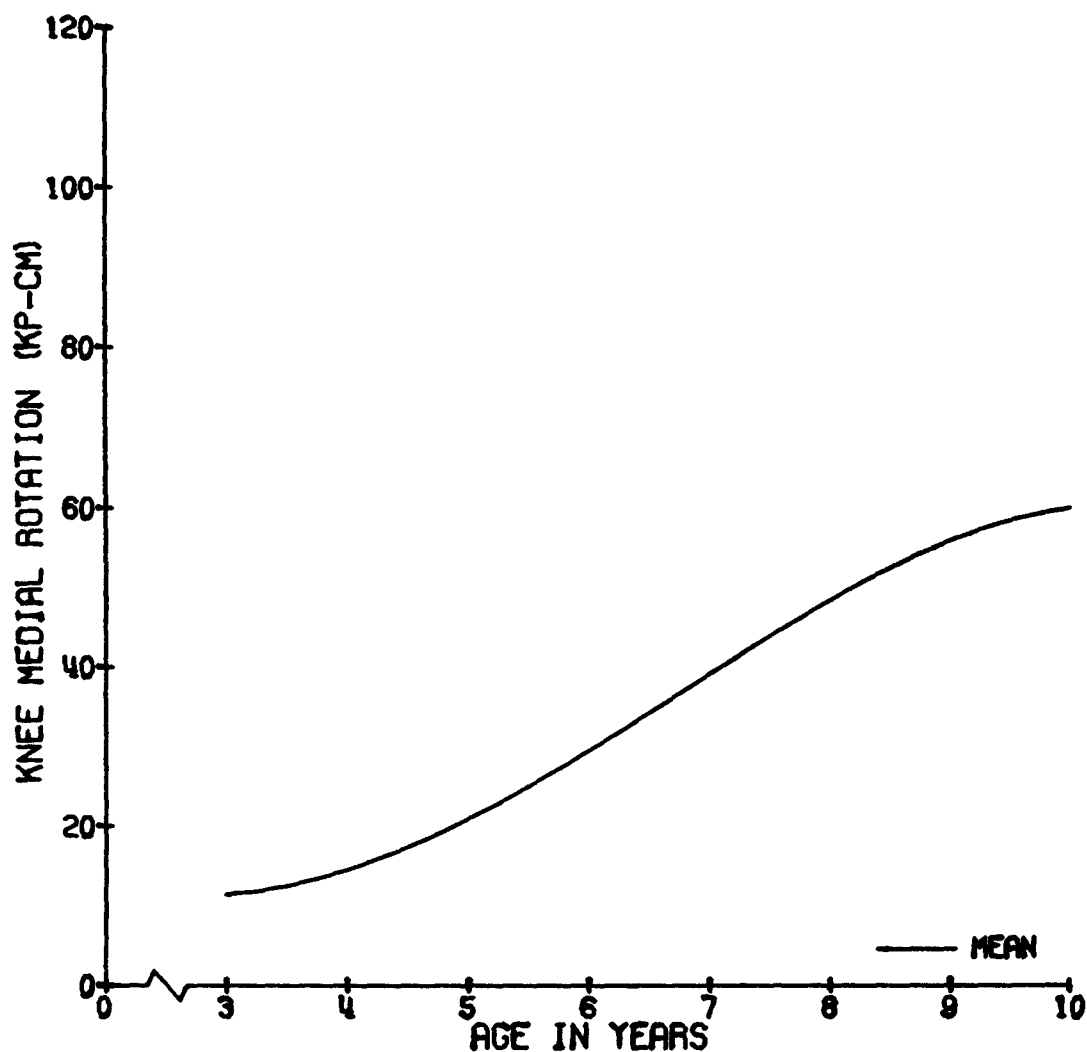

KNEE LATERAL ROTATION

DESCRIPTION OF TEST: (for flexed knee only) The tibia and fibula are rotated at the knee joint (femorotibial joint center) moving the anterior surface of the tibia laterally away from the midline of the body.

TEST POSITION: The hip is flexed 85° , the knee flexed 90° .

ANTHROPOMETRIC MEASUREMENTS: The femoral, tibial and tarsal linkages are measured with an anthropometer.

ADJUSTMENT OF EQUIPMENT: The chair leg fixtures are set to the femoral and tibial lengths, aligning the hip, knee and ankle joint centers with those of the chair. Thin rubber pads are placed under the leg to maintain these alignments. The hip flexion angle is locked at 85° and the knee flexion angle at 90° . The chest, pelvic, knee, foot and ankle straps are then secured snugly around the hips and right leg as well as the knee strap on the left leg. The left foot is free to rest on the left foot support.

INSTRUCTIONS TO SUBJECT: The child pulls his toes to his right and his heel to his left.

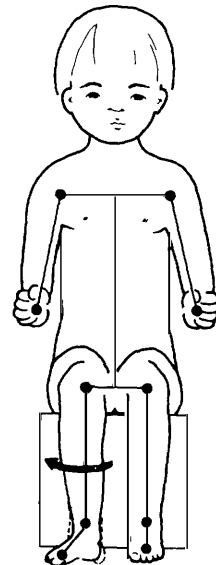
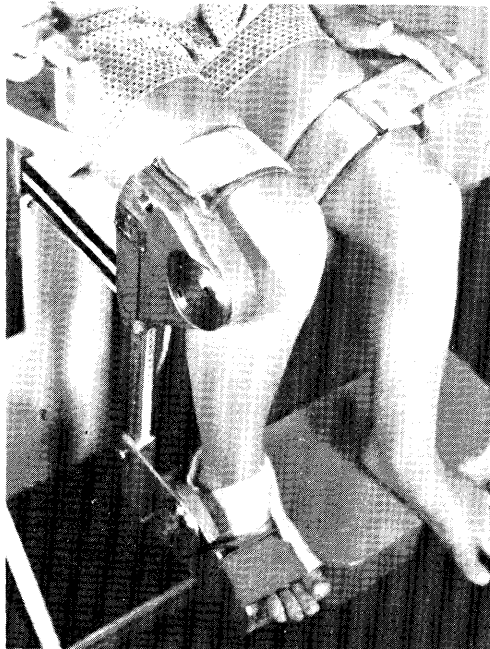

KNEE LATERAL ROTATION, 9 DEG. (KP-CM)

COMBINED SEXES

AGE	N	MEAN	ST. DEV	MIN	10%	MEDIAN	90%	MAX
3	7	8.9	3.4	5.1	5.1	9.1	14.8	14.8
4	35	11.0	4.5	2.8	4.7	10.3	16.7	20.3
5	30	15.2	6.4	6.6	7.7	13.5	24.9	30.4
6	41	23.4	8.5	8.5	13.0	23.2	33.7	48.6
7	31	27.7	9.2	8.4	14.3	27.8	40.0	43.7
8	31	40.7	18.2	13.5	20.3	35.9	64.1	75.9
9	32	53.3	16.5	27.1	36.8	49.7	80.7	89.0
10	15	57.1	14.4	35.0	40.8	54.5	84.0	84.1

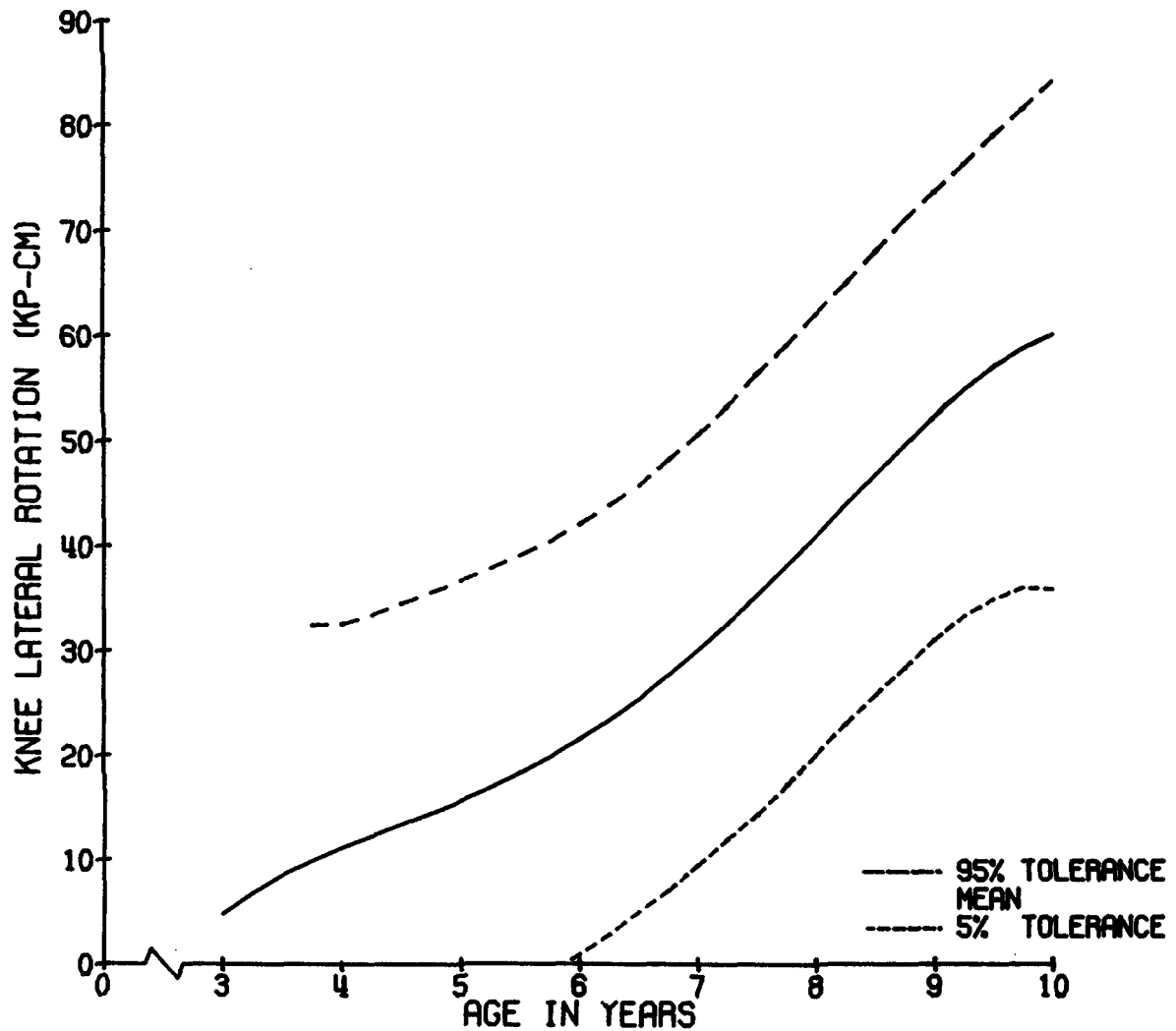

KNEE LATERAL ROTATION, 0 DEG. (KP-CM)

MALES

AGE	N	MEAN	ST. DEV	MIN	10%	MEDIAN	90%	MAX
3	5	8.6	4.1	5.1	5.1	7.1	14.8	14.8
4	17	12.9	4.3	4.5	7.2	10.5	17.8	20.3
5	19	15.6	7.1	7.7	7.7	12.6	24.9	30.0
6	26	22.1	8.1	8.5	10.4	22.2	31.4	40.6
7	14	26.7	10.5	8.4	13.0	28.0	42.5	43.0
8	19	40.2	20.9	13.5	15.3	35.9	73.9	75.9
9	13	59.6	17.2	30.0	36.8	56.7	82.7	84.7
10	7	64.1	14.8	47.9	47.9	56.1	84.1	84.1

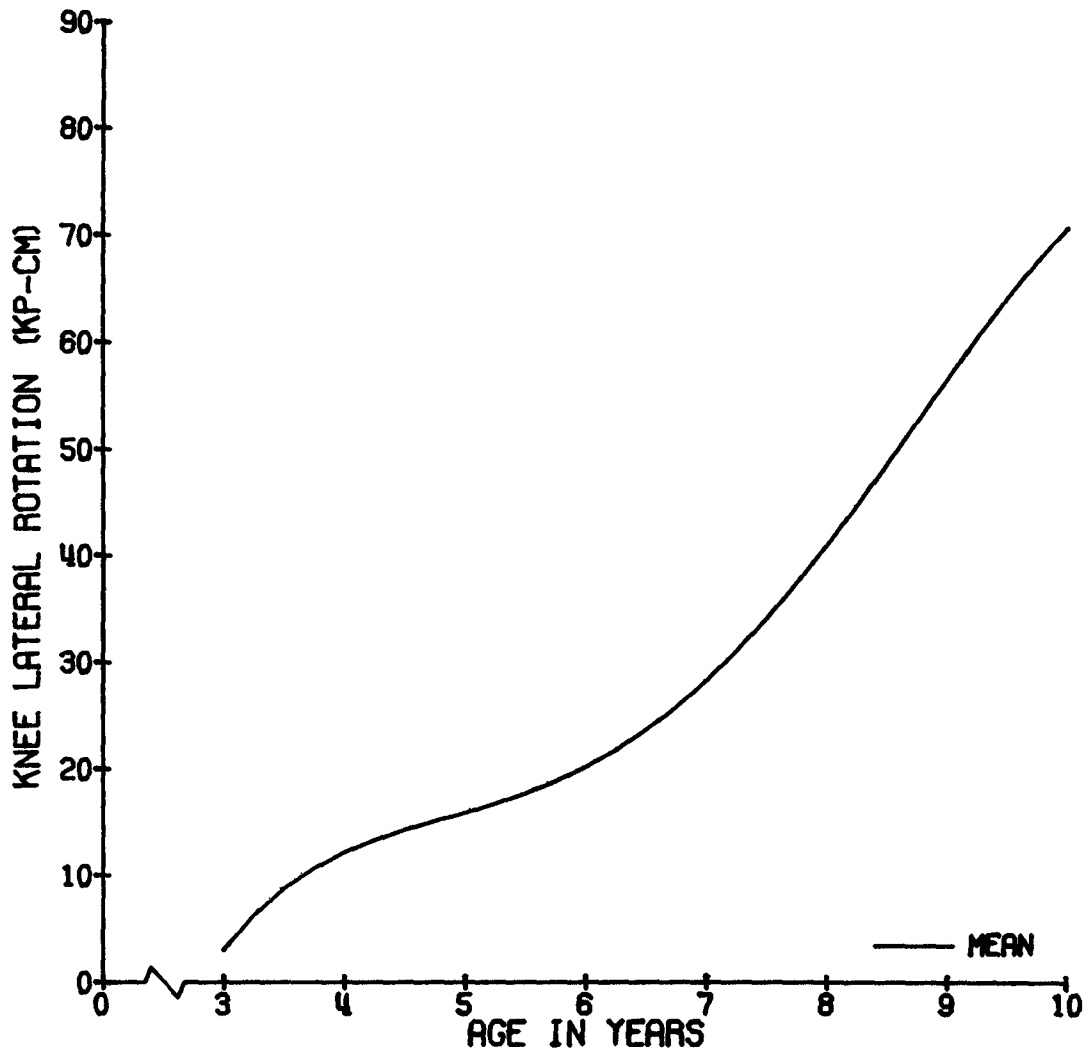

KNEE LATERAL ROTATION, 0 DEG. (KP-CM)

FEMALES

AGE	N	MEAN	ST. DEV	MIN	10%	MEDIAN	90%	MAX
3	2	9.6	0.7	9.1	9.1	9.6	10.1	10.1
4	18	10.0	4.5	2.8	3.3	9.2	16.7	17.6
5	20	15.0	6.2	6.6	6.7	14.4	21.6	30.4
6	15	25.7	9.1	12.4	18.6	23.4	37.5	48.6
7	17	28.5	8.2	14.3	18.6	27.8	40.0	43.7
8	12	41.6	13.5	20.3	27.8	39.3	56.1	64.1
9	19	49.0	14.9	27.1	33.5	44.5	79.6	89.0
10	8	51.0	11.5	35.0	35.0	50.6	72.2	72.2

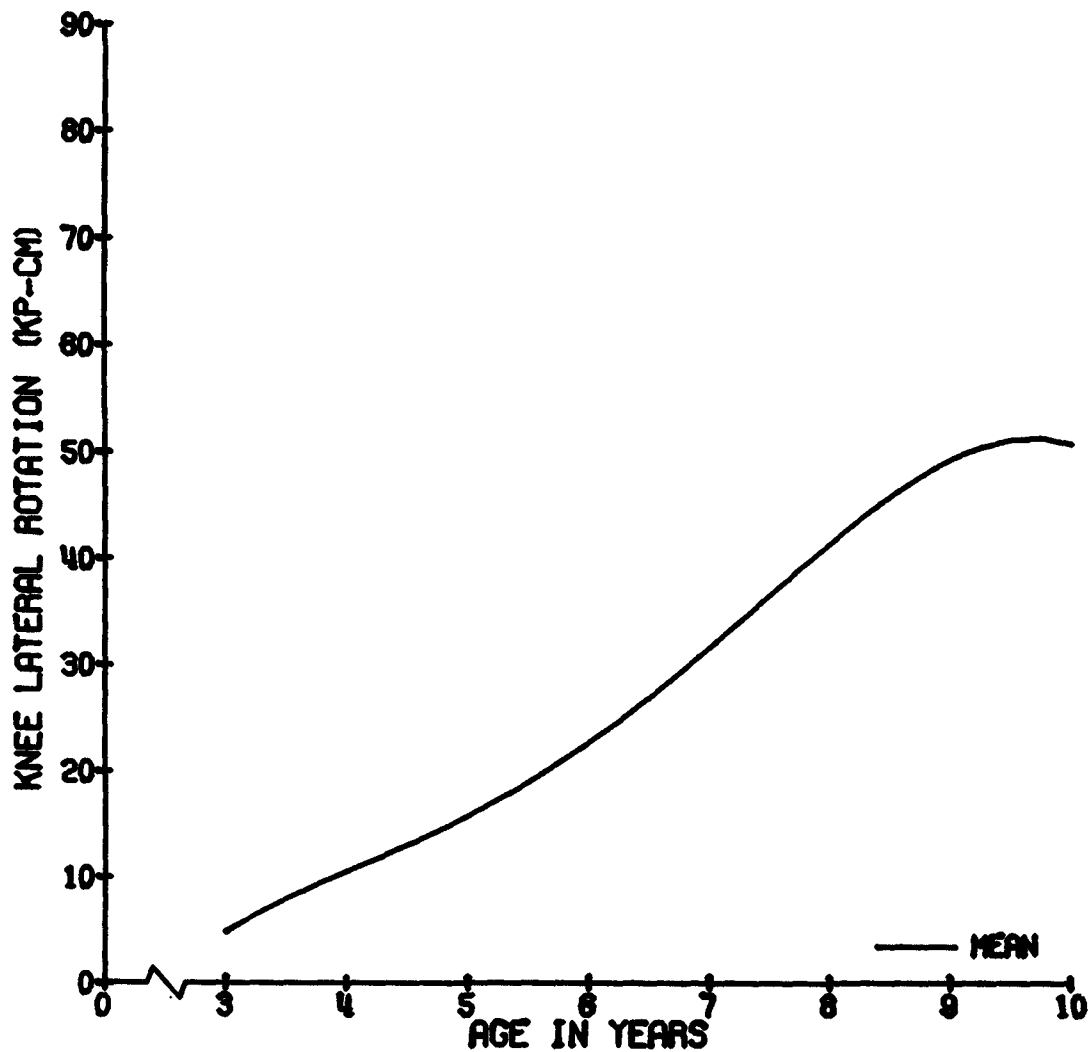

HIP FLEXION

DESCRIPTION OF TEST: The femur is rotated anteriorly at the hip joint center (femoral head) in the sagittal plane.

TEST POSITION: The hip is flexed 85° , the knee flexed 90° .

ANTHROPOMETRIC MEASUREMENTS: The femoral, tibial and tarsal linkages are measured with an anthropometer.

ADJUSTMENT OF EQUIPMENT: The chair leg fixtures are set to the femoral and tibial lengths, aligning the hip, knee and ankle joint centers with those of the chair. Thin rubber pads are placed under the leg to maintain these alignments. The hip flexion angle is locked at 85° and the knee flexion angle at 90° . The chest, pelvic, knee, foot and ankle straps are then secured snugly around the hips and right leg as well as the knee strap on the left leg. The left foot is free to rest on the left foot support.

INSTRUCTIONS TO SUBJECT: The child pulls his knee (and lower leg) up.

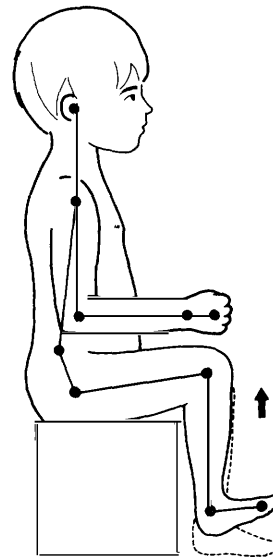
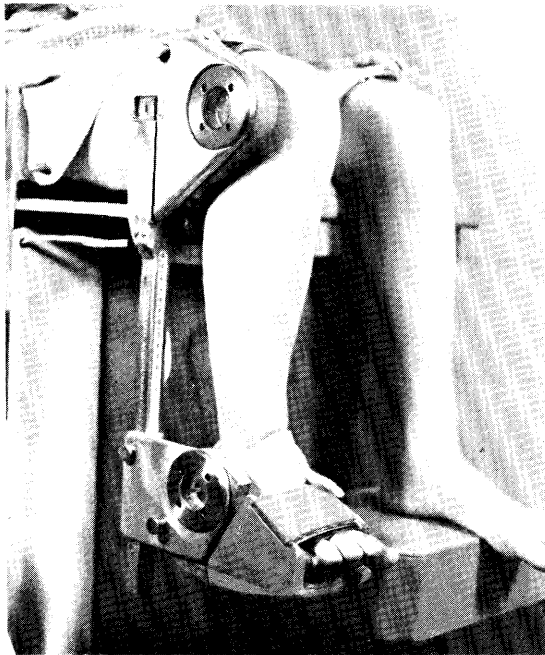

HIP FLEXION, 85 DEG. (KP-CM)

COMBINED SEXES

AGE	N	MEAN	SP. DEV	MIN	10%	MEDIAN	90%	MAX
3	10	96.2	32.7	51.2	51.2	95.1	142.3	148.9
4	72	148.9	47.0	40.6	85.7	142.0	213.8	250.2
5	80	193.1	59.4	85.8	126.2	177.9	279.1	400.6
6	69	233.3	67.8	83.8	146.6	237.0	334.7	425.3
7	79	362.5	105.4	85.7	247.2	353.0	521.8	597.7
8	71	453.6	113.9	227.3	290.1	467.5	596.2	709.3
9	81	496.5	131.6	151.5	360.6	491.7	653.6	950.2
10	28	557.5	144.0	254.1	387.8	537.6	753.4	800.5

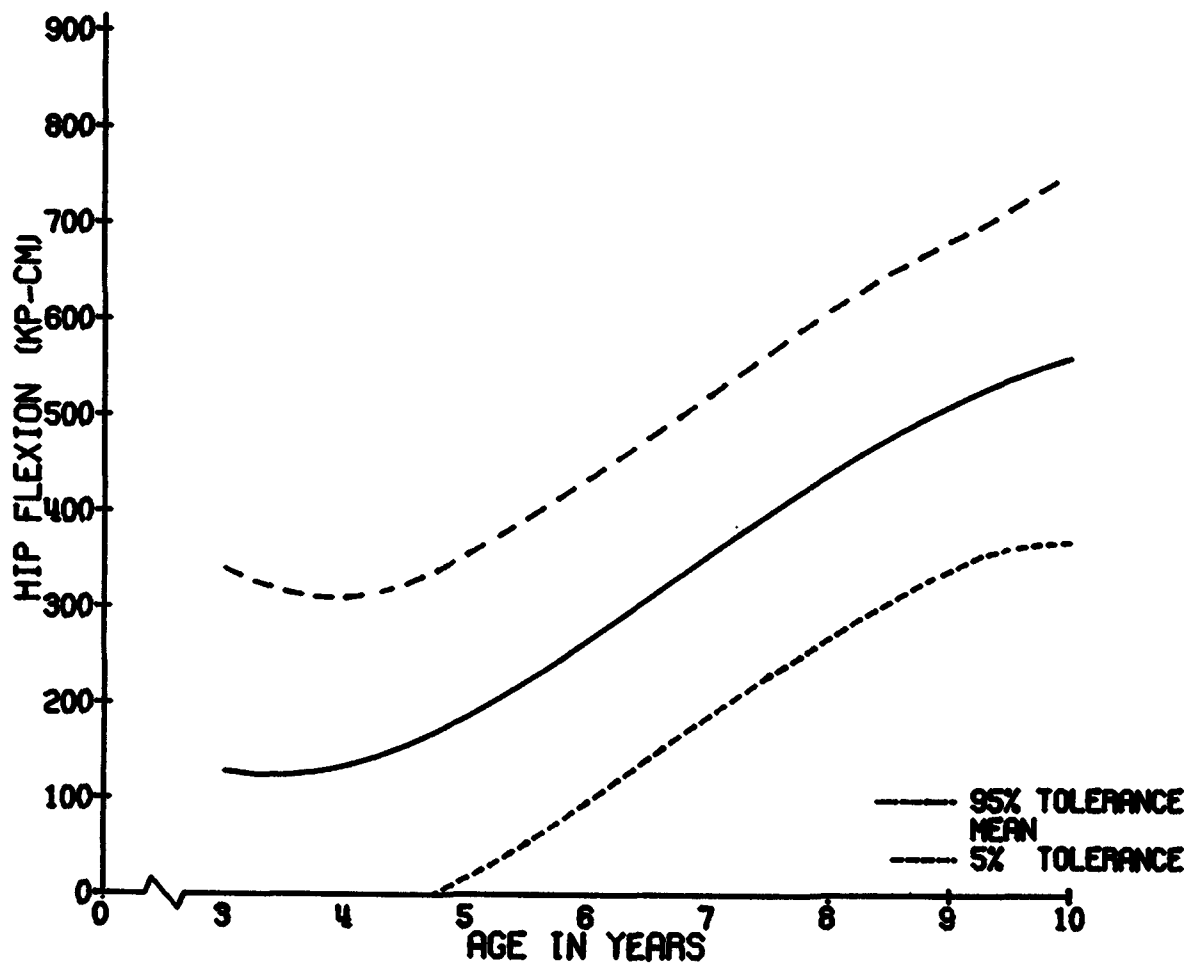

HIP FLEXION, 85 DEG. (KP-CM)

MALES

AGE	N	MEAN	ST. DEV	MIN	10%	MEDIAN	90%	MAX
3	7	103.7	37.5	51.2	51.2	106.0	148.9	148.9
4	31	148.6	46.0	40.6	83.2	158.1	209.6	217.6
5	32	202.7	71.3	101.2	126.7	188.9	296.8	400.6
6	38	246.5	67.4	120.2	151.9	249.0	339.0	425.3
7	36	378.7	114.5	85.7	239.6	365.0	529.5	597.7
8	37	457.1	113.2	260.9	288.3	462.5	606.0	709.3
9	38	553.2	122.7	336.4	393.9	542.5	719.8	950.2
10	16	578.1	167.8	254.1	369.4	607.9	798.2	800.5

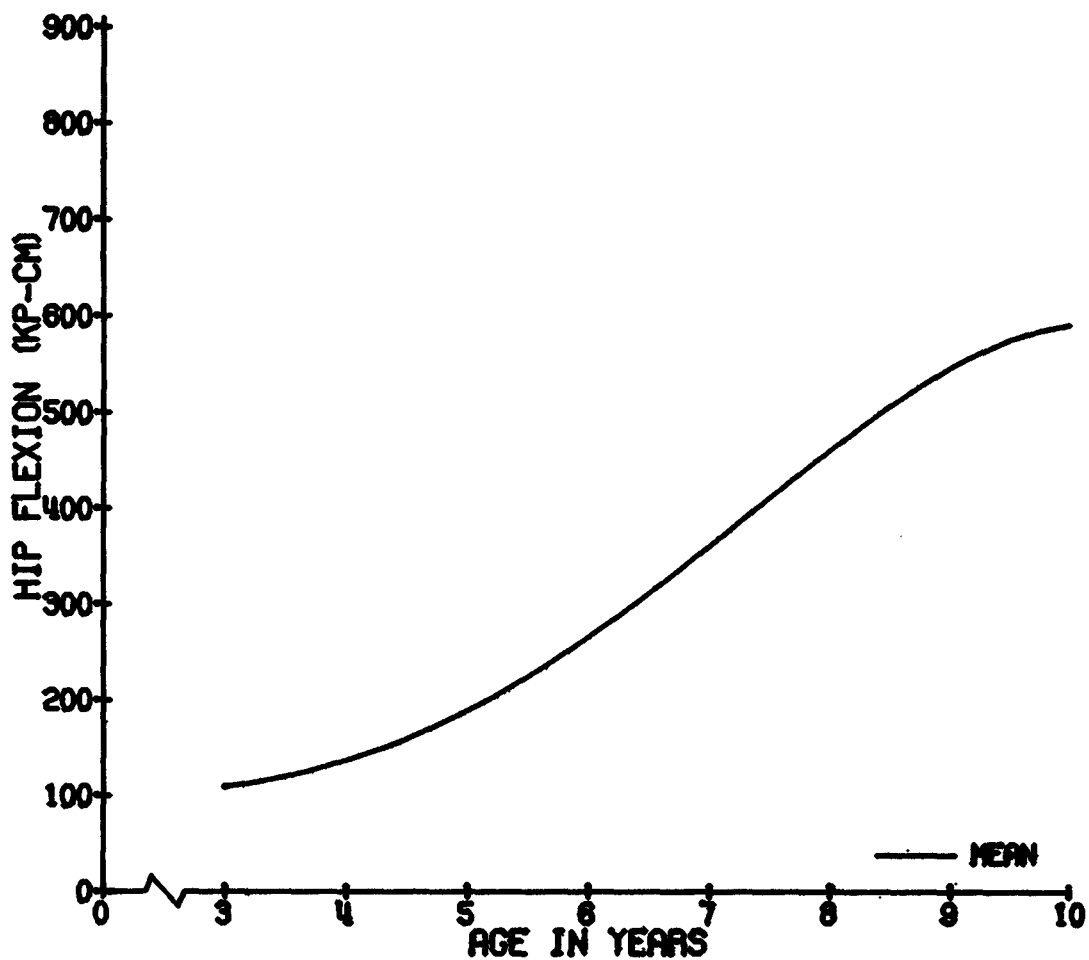

HIP FLEXION, 85 DEG. (KP-CM)

FEMALES

AGE	N	MEAN	ST. DEV	MIN	10%	MEDIAN	90%	MAX
3	3	85.8	18.9	67.0	67.0	85.6	104.7	104.7
4	41	149.1	47.8	66.4	86.1	140.1	214.3	250.2
5	48	186.7	49.7	85.8	126.2	176.9	267.1	292.1
6	31	228.4	68.1	83.8	146.6	215.4	296.8	411.0
7	43	348.9	96.5	158.9	251.3	337.8	491.8	574.3
8	34	449.6	116.2	227.3	290.1	468.4	594.2	655.9
9	43	446.3	119.4	151.5	305.8	446.4	570.2	816.0
10	12	513.8	99.6	387.8	393.8	513.6	580.8	753.4

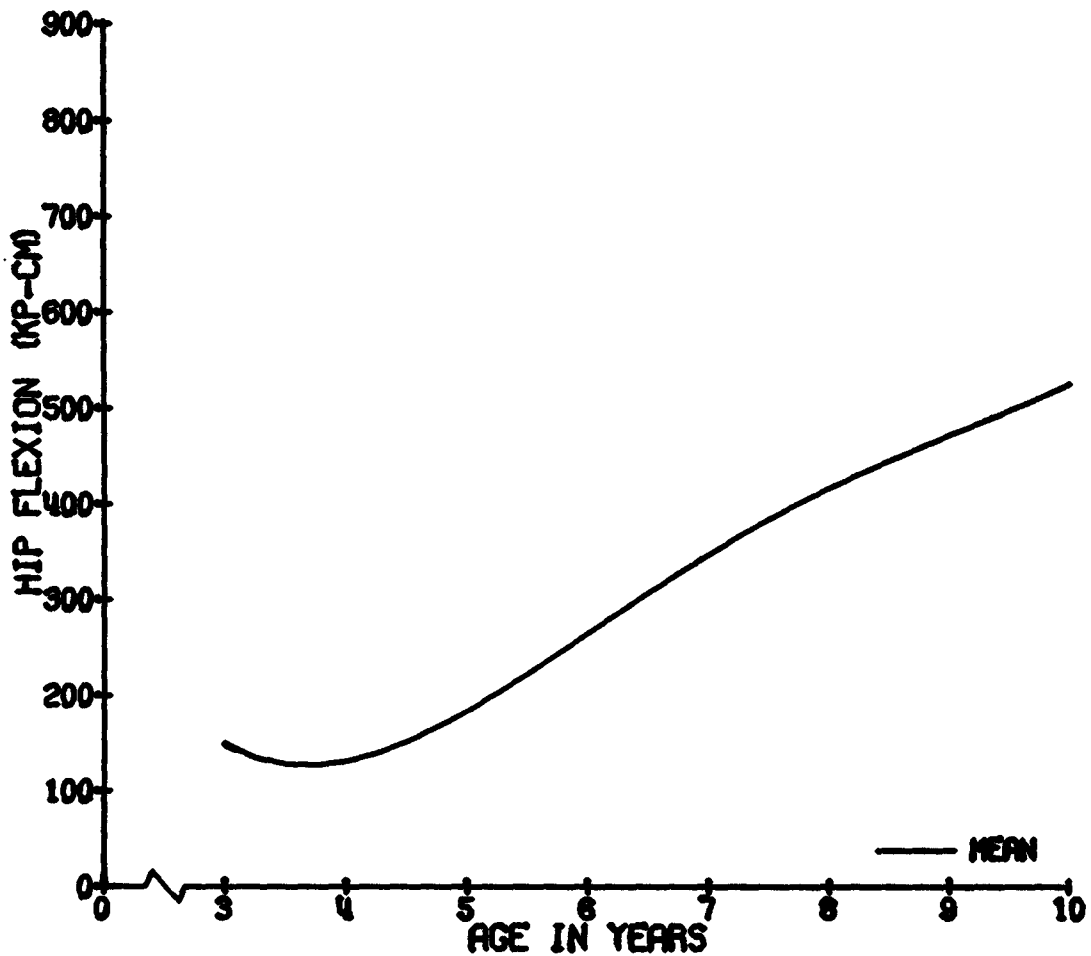

HIP EXTENSION

DESCRIPTION OF TEST: The femur is rotated posteriorly at the hip joint center (femoral head) in the sagittal plane.

TEST POSITION: The hip is flexed 85° , the knee flexed 90° .

ANTHROPOMETRIC MEASUREMENTS: The femoral, tibial and tarsal linkages are measured with an anthropometer.

ADJUSTMENT OF EQUIPMENT: The chair leg fixtures are set to the femoral and tibial lengths, aligning the hip, knee and ankle joint centers with those of the chair. Thin rubber pads are placed under the leg to maintain these alignments. The hip flexion angle is locked at 85° and the knee flexion angle at 90° . The chest, pelvic, knee, foot and ankle straps are then secured snugly around the hips and right leg as well as the knee strap on the left leg. The left foot is free to rest on the left foot support.

INSTRUCTIONS TO SUBJECT: The child pushes his knee (and lower leg) down.

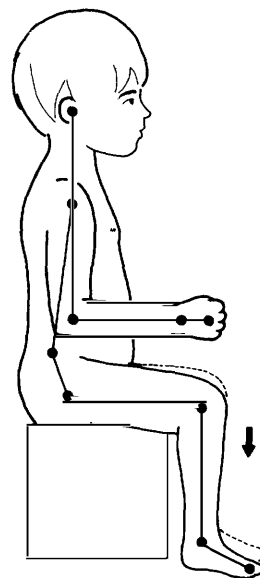
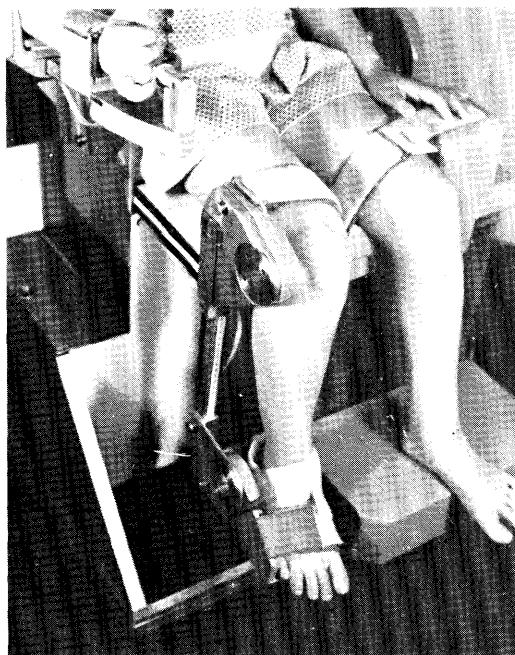

HIP EXTENSION, 85 DEG. (KP-CM)

COMBINED SEXES

AGE	N	MEAN	ST. DEV	MIN	10%	MEDIAN	90%	MAX
3	12	155.8	71.2	55.6	58.1	158.8	224.2	282.8
4	74	210.7	80.3	35.6	121.0	210.8	321.3	505.6
5	81	263.7	99.0	85.4	143.7	255.5	380.4	562.3
6	70	313.5	93.0	135.3	202.3	300.8	424.9	614.7
7	78	389.6	102.8	196.1	255.1	376.3	537.4	618.1
8	71	453.2	98.2	191.4	320.8	473.3	570.5	629.8
9	81	474.4	85.9	304.7	350.0	483.8	585.2	679.0
10	28	475.7	86.0	254.5	371.5	471.3	583.4	645.3

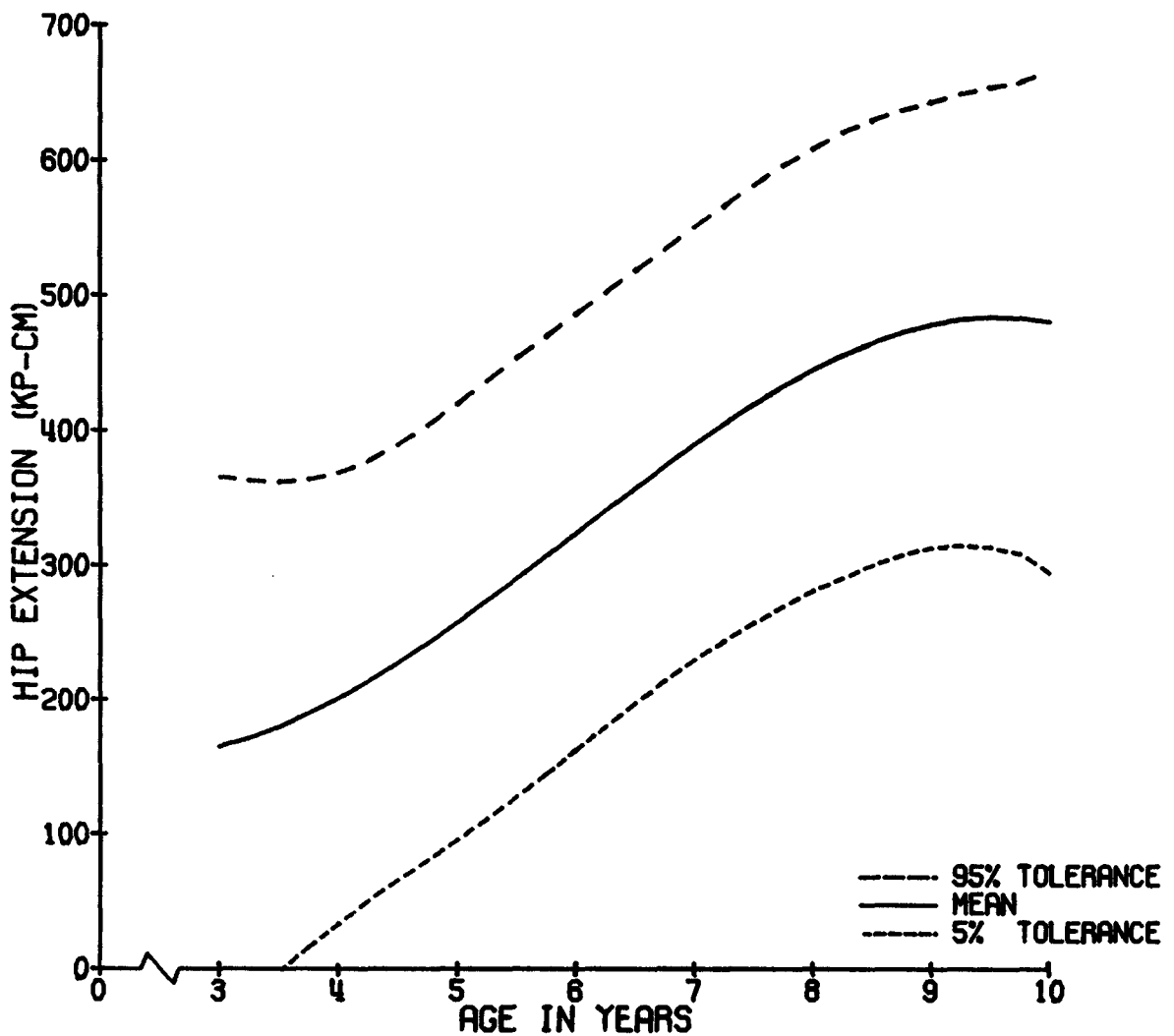

HIP EXTENSION, 85 DEG. (KP-CM)

MALES

AGE	N	MEAN	ST. DEV	MIN	10%	MEDIAN	90%	MAX
3	9	162.0	60.0	55.6	55.6	177.1	224.2	224.2
4	32	230.1	78.1	104.5	160.6	219.8	321.8	505.6
5	32	301.2	114.7	126.1	144.8	277.5	474.2	562.3
6	38	322.6	90.9	176.3	215.7	298.9	425.2	614.7
7	35	390.0	103.8	203.8	261.6	366.5	537.6	583.3
8	37	458.3	91.1	301.0	323.4	475.5	586.2	629.2
9	38	496.2	70.3	333.5	428.3	493.3	588.4	679.0
10	16	472.6	97.0	254.5	362.5	480.2	606.9	645.3

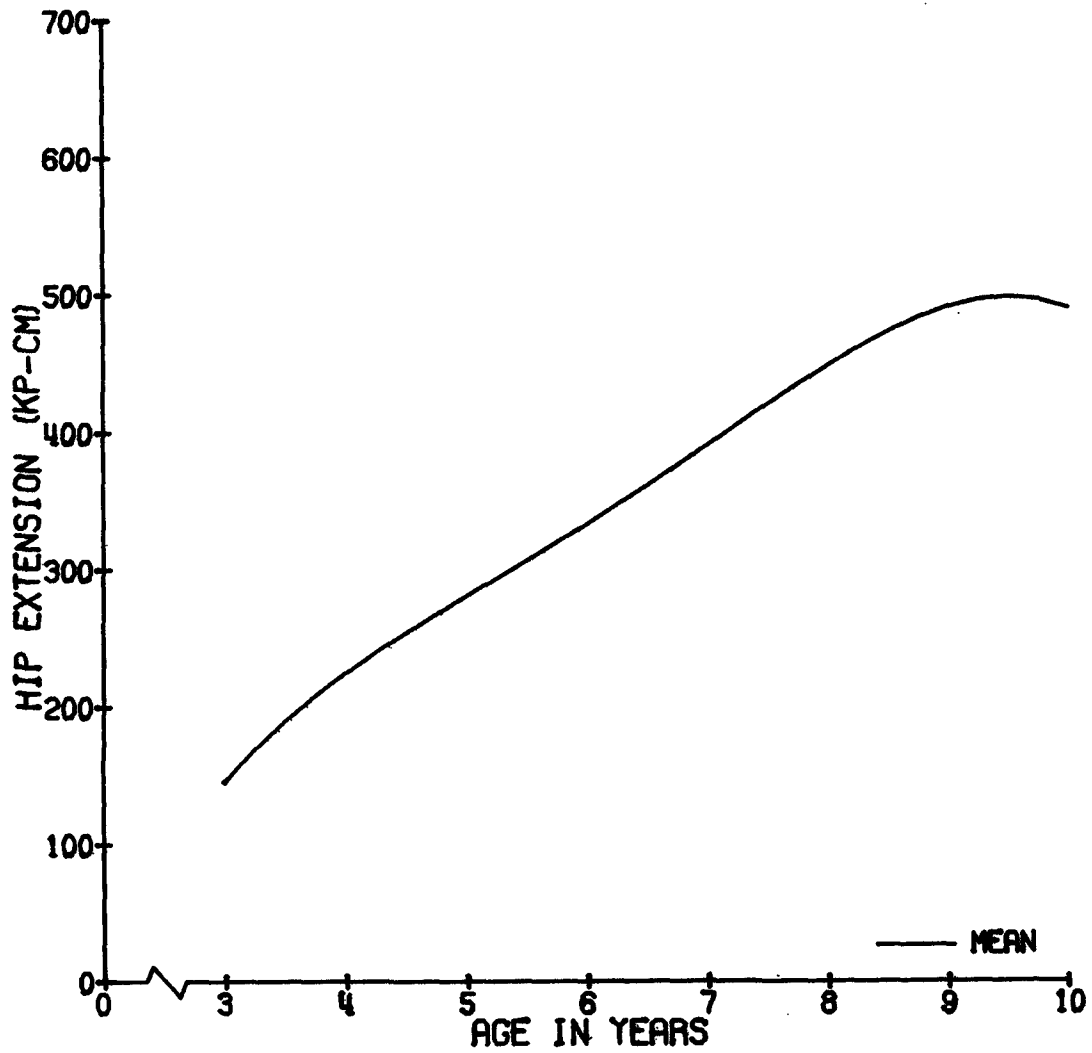

HIP EXTENSION, 85 DEG. (KP-CM)

FEMALES

AGE	N	MEAN	ST. DEV	MIN	10%	MEDIAN	90%	MAX
3	4	143.2	99.3	58.1	58.1	115.9	282.8	282.8
4	42	195.9	79.7	35.6	115.2	199.3	263.5	396.4
5	49	239.2	79.2	85.4	118.9	241.7	332.6	451.3
6	32	302.7	95.9	135.3	186.6	307.1	424.9	504.5
7	43	389.3	103.3	196.1	255.1	386.2	498.4	618.1
8	34	447.1	106.4	191.4	283.7	471.9	570.5	629.8
9	43	455.1	94.3	304.7	338.3	456.6	585.2	643.5
10	12	479.7	72.8	401.4	407.3	436.3	583.0	583.4

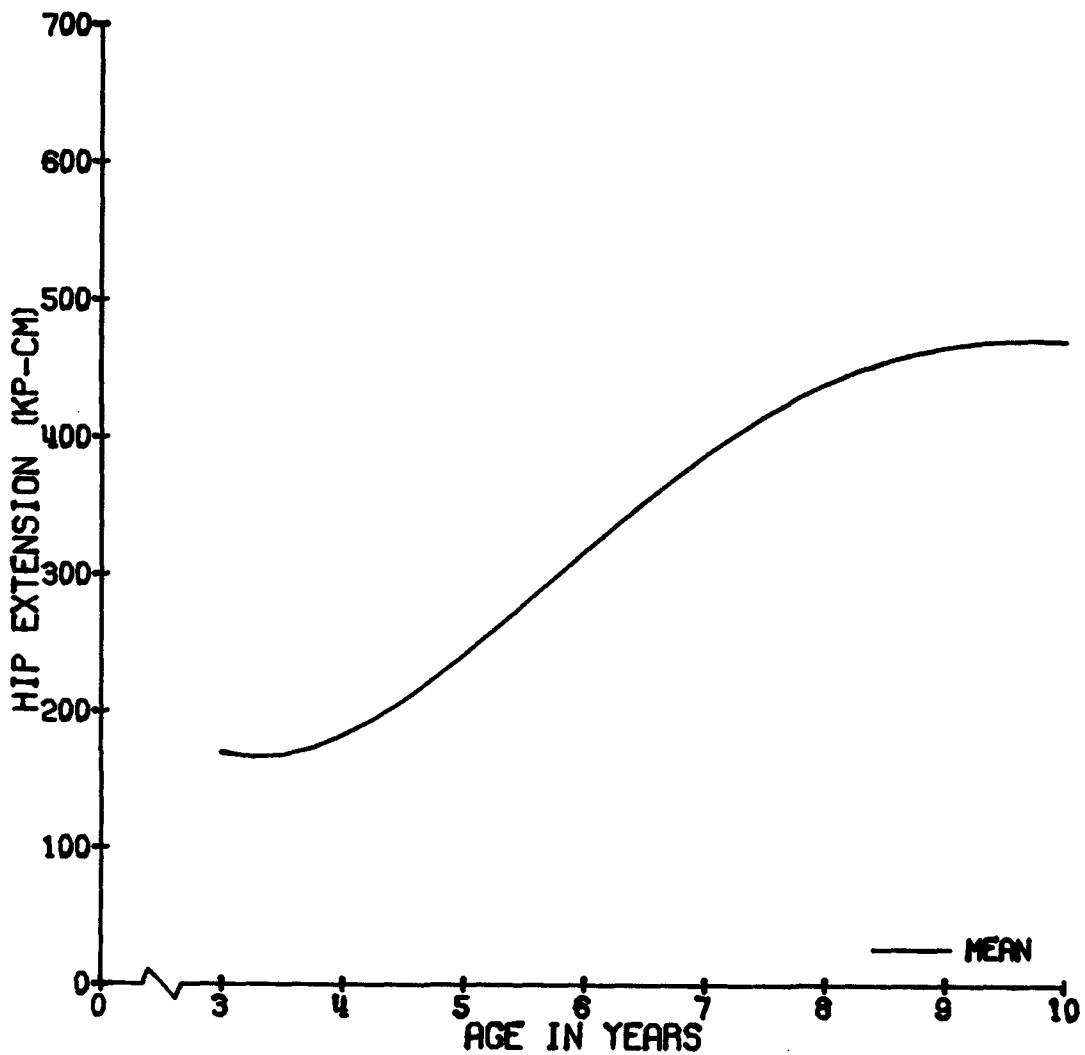

HIP ADDUCTION

DESCRIPTION OF TEST: The femur is rotated medially at the hip joint (femoral head) in the coronal plane.

TEST POSITION: The hip is flexed 85° , the knee flexed 90° .

ANTHROPOMETRIC MEASUREMENTS: The femoral, tibial and tarsal linkages are measured with an anthropometer.

ADJUSTMENT OF EQUIPMENT: The chair leg fixtures are set to the femoral and tibial lengths, aligning the hip, knee and ankle joint centers with those of the chair. Thin rubber pads are placed under the leg to maintain these alignments. The hip flexion angle is locked at 85° and the knee flexion angle at 90° . The chest, pelvic, knee, foot and ankle straps are then secured snugly around the hips and right leg as well as the knee strap on the left leg. The left foot is free to rest on the left foot support.

INSTRUCTIONS TO SUBJECT: The child pulls his knee (and lower leg) to his left.

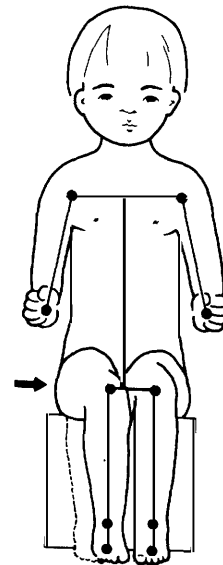

HIP ADDUCTION, 0 DEG. (KP-CM)

COMBINED SEXES

AGE	N	MEAN	ST. DEV	MIN	10%	MEDIAN	90%	MAX
3	9	66.1	23.1	36.0	36.0	69.5	101.6	101.6
4	37	92.3	39.5	26.6	52.9	85.5	136.8	205.3
5	34	92.6	39.3	49.2	52.6	78.4	166.9	180.6
6	58	120.7	54.8	44.2	61.9	113.1	203.8	287.7
7	78	162.6	53.3	48.6	97.7	155.4	230.8	292.2
8	71	190.1	63.1	50.8	111.7	197.2	263.3	354.6
9	81	199.9	67.9	72.0	116.3	193.1	283.0	359.5
10	28	229.5	64.4	111.9	138.9	233.5	307.3	382.9

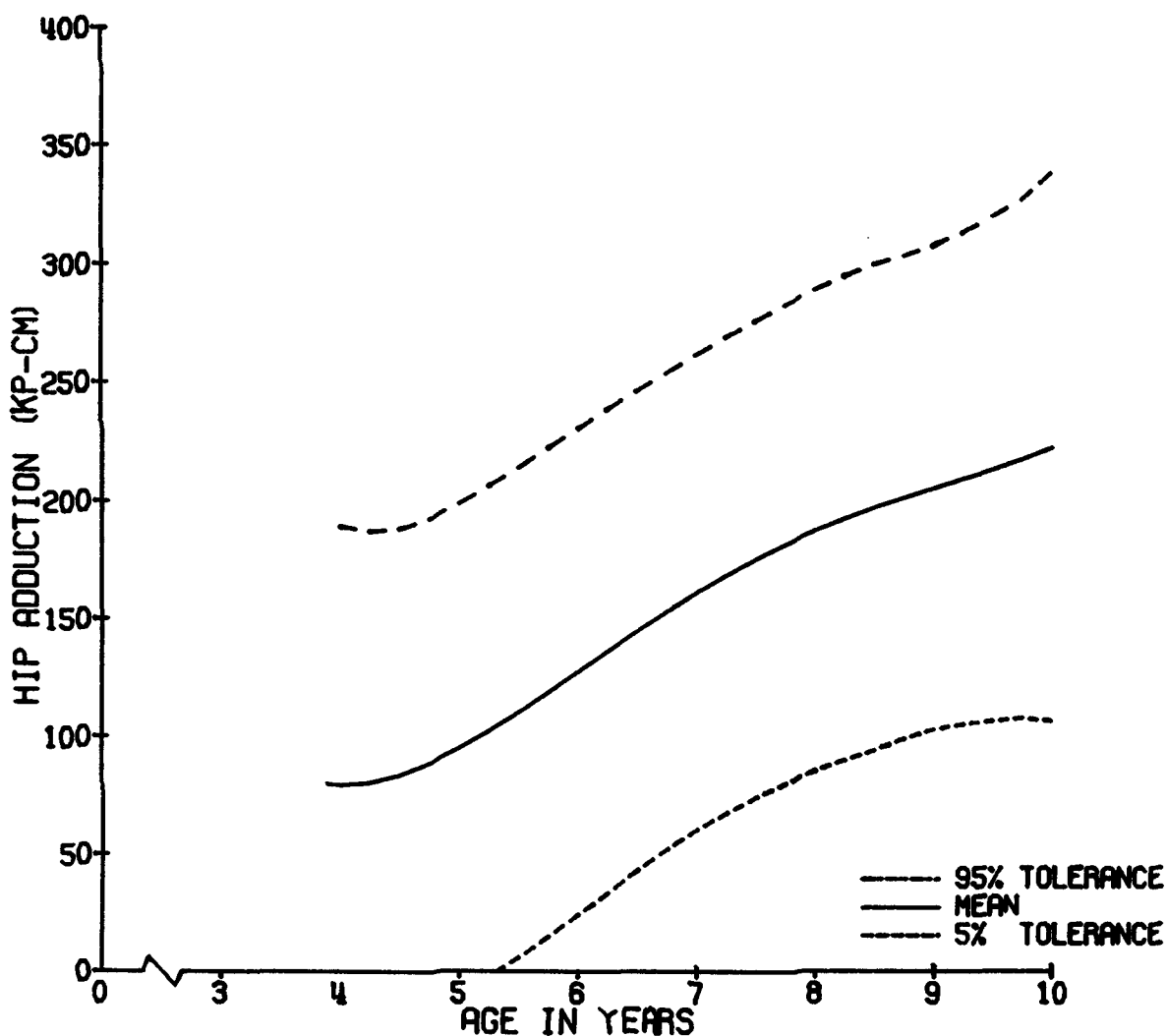

HIP ADDUCTION, ° DEG. (KP-CM)

MALES

AGE	N	MEAN	ST. DEV	MIN	10%	MEDIAN	90%	MAX
3	7	64.9	19.5	36.0	36.0	69.5	86.8	86.8
4	19	93.9	39.7	39.0	48.9	85.5	150.8	178.1
5	12	105.7	49.9	49.2	52.4	87.5	170.5	180.6
6	33	118.3	57.2	44.2	61.6	106.2	209.9	235.5
7	35	168.9	62.0	59.2	87.4	162.5	256.6	289.0
8	37	187.6	59.3	80.5	111.7	187.8	252.1	354.6
9	38	221.3	67.9	72.3	126.3	229.1	320.4	359.5
10	16	245.9	67.2	111.0	169.5	249.4	359.0	382.9

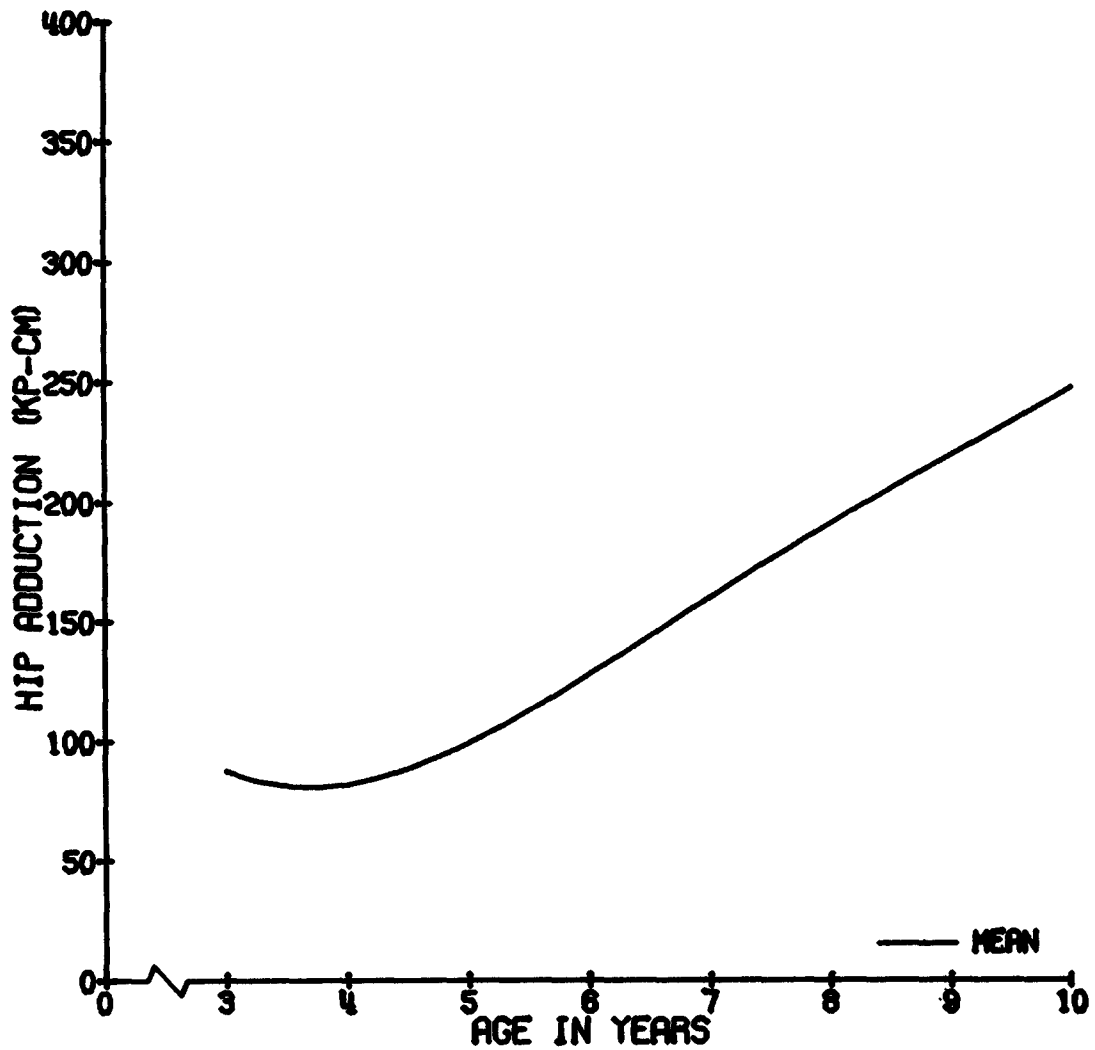

HIP ADDUCTION, 0 DEG. (KP-CM)

FEMALES

AGE	N	MEAN	ST. DEV	MIN	10%	MEDIAN	90%	MAX
3	2	70.4	44.1	39.2	39.2	70.4	101.6	101.6
4	18	90.7	40.4	26.6	55.8	86.7	124.3	205.3
5	22	85.5	31.1	52.4	56.3	76.5	134.8	170.9
6	25	123.2	52.5	56.3	69.0	113.7	175.8	237.7
7	43	157.5	45.1	48.6	109.7	145.4	214.6	292.2
8	34	192.8	67.3	50.8	111.3	199.3	264.2	321.8
9	43	180.6	62.4	72.0	98.5	175.0	274.1	314.7
10	12	207.6	55.7	124.5	138.9	200.2	275.1	307.3

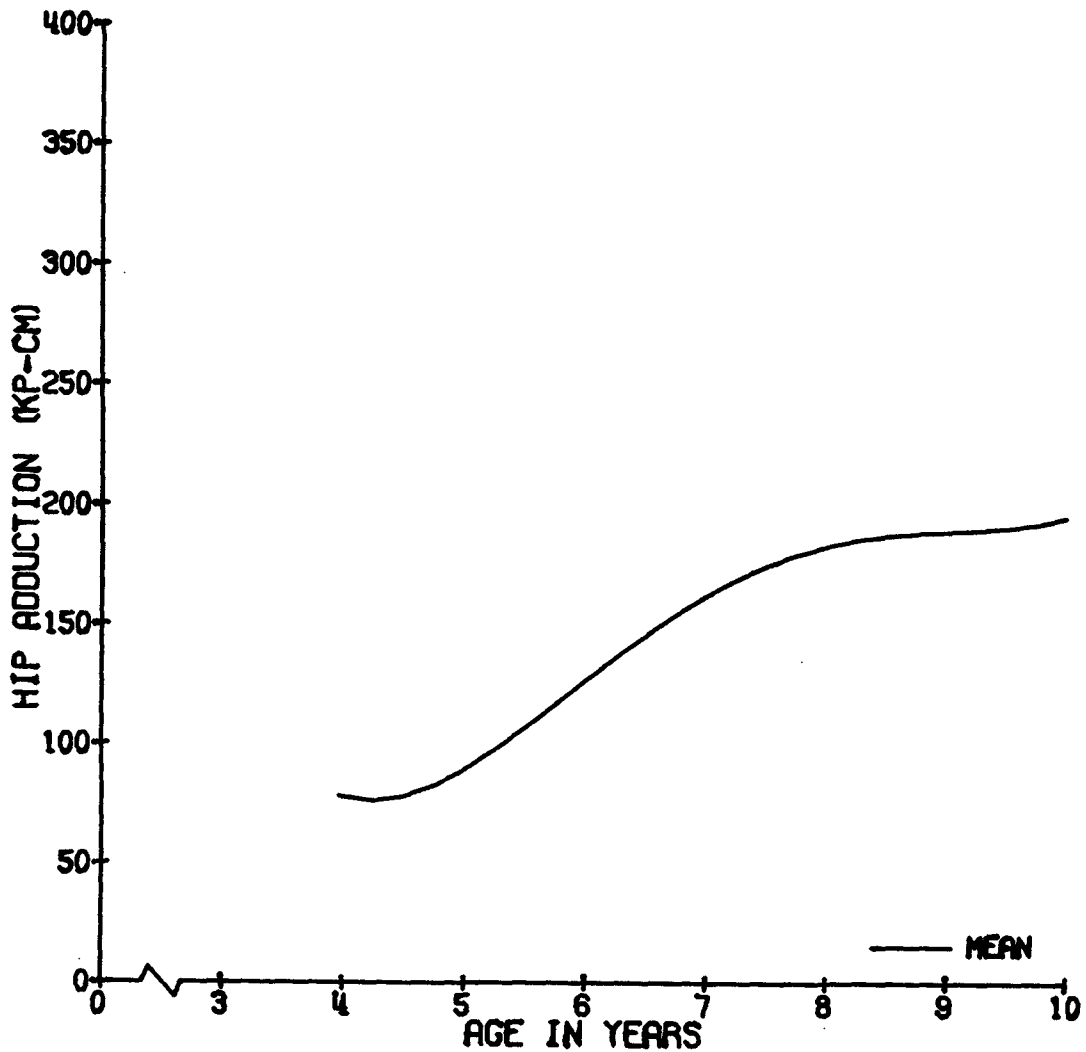

HIP ABDUCTION

DESCRIPTION OF TEST: The femur is rotated laterally at the hip joint (femoral head) in the coronal plane.

TEST POSITION: The hip is flexed 85° , the knee flexed 90° .

ANTHROPOMETRIC MEASUREMENTS: The femoral, tibial and tarsal linkages are measured with an anthropometer.

ADJUSTMENT OF EQUIPMENT: The chair leg fixtures are set to the femoral and tibial lengths, aligning the hip, knee and ankle joint centers with those of the chair. Thin rubber pads are placed under the leg to maintain these alignments. The hip flexion angle is locked at 85° and the knee flexion angle at 90° . The chest, pelvic, knee, foot and ankle straps are then secured snugly around the hips and right leg as well as the knee strap on the left leg. The left foot is free to rest on the left foot support.

INSTRUCTIONS TO SUBJECT: The child pushes his knee (and lower leg) to his right.

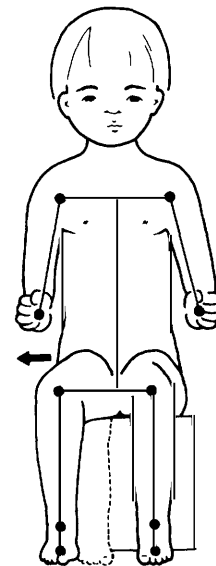

HIP ABDUCTION, 0 DEG. (KP-CM)

COMBINED SEXES

AGE	N	MEAN	ST. DEV	MIN	10%	MEDIAN	90%	MAX
3	9	70.2	26.1	30.3	30.3	75.0	99.9	99.9
4	37	104.3	35.5	35.3	52.9	103.1	148.3	178.4
5	35	125.9	42.1	49.6	83.0	115.2	174.7	254.5
6	55	159.7	46.3	52.8	108.7	152.2	214.1	280.7
7	32	176.7	49.3	52.4	127.9	172.2	232.3	280.3
8	31	242.5	81.1	86.0	138.1	225.2	346.0	382.7
9	33	279.6	70.5	113.2	162.1	288.6	352.8	410.2
10	15	322.1	70.1	179.3	229.9	348.3	397.4	436.0

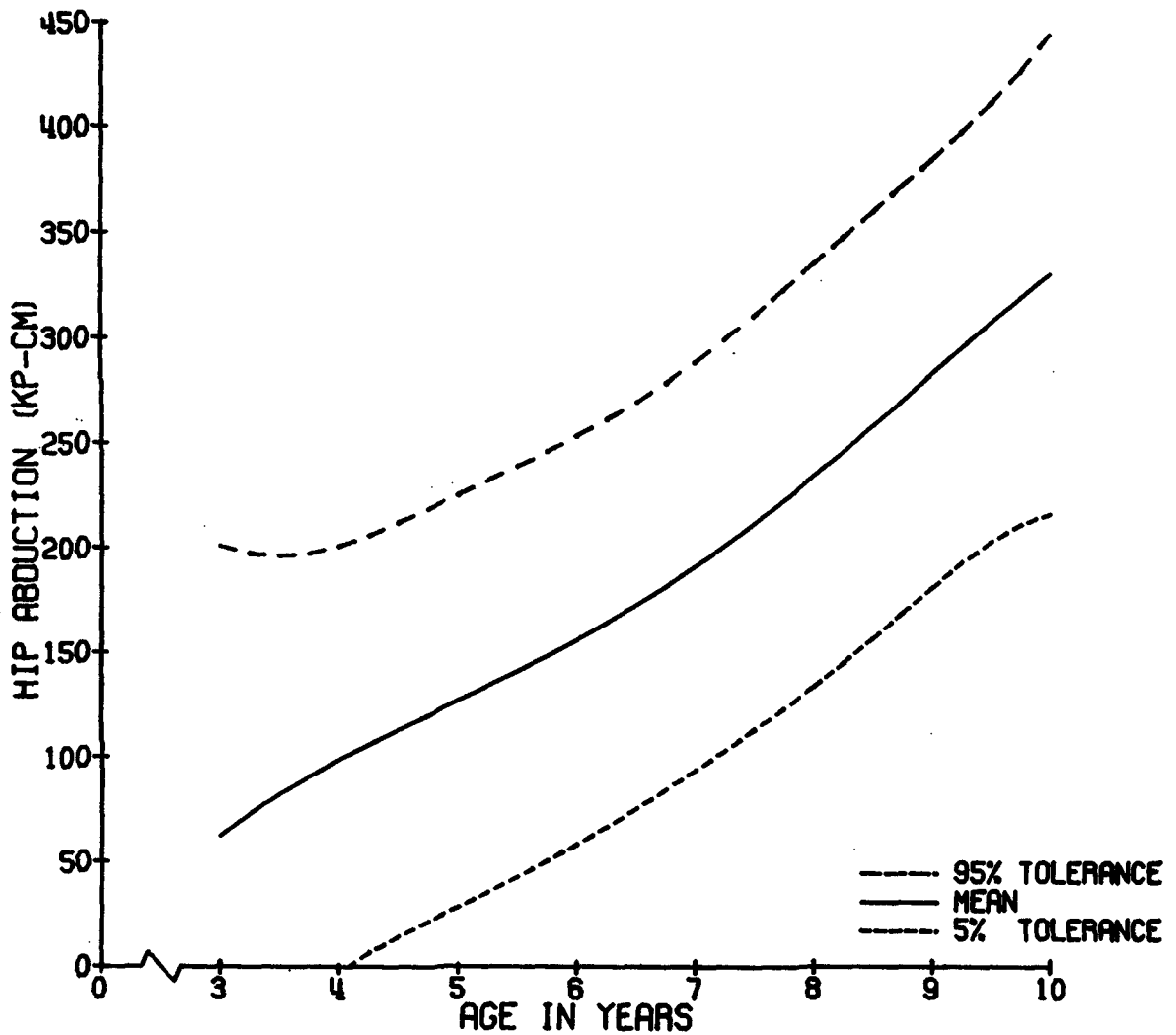

HIP ABDUCTION, ° DEG. (KP-CM)

MALES

AGE	N	MEAN	ST. DEV	MIN	10%	MEDIAN	90%	MAX
3	7	75.6	24.8	30.3	30.3	78.5	99.9	99.9
4	19	105.1	36.4	35.3	52.5	105.4	160.3	178.4
5	12	127.3	51.2	83.0	84.1	109.3	196.2	254.5
6	32	176.9	45.0	95.8	118.4	174.0	230.2	280.7
7	14	177.9	60.9	52.4	91.0	181.6	232.3	280.3
8	19	230.6	72.5	125.6	135.0	211.6	337.3	354.3
9	14	293.6	62.3	162.1	229.2	300.9	361.2	403.7
10	7	338.2	71.5	229.9	229.9	357.6	436.0	436.0

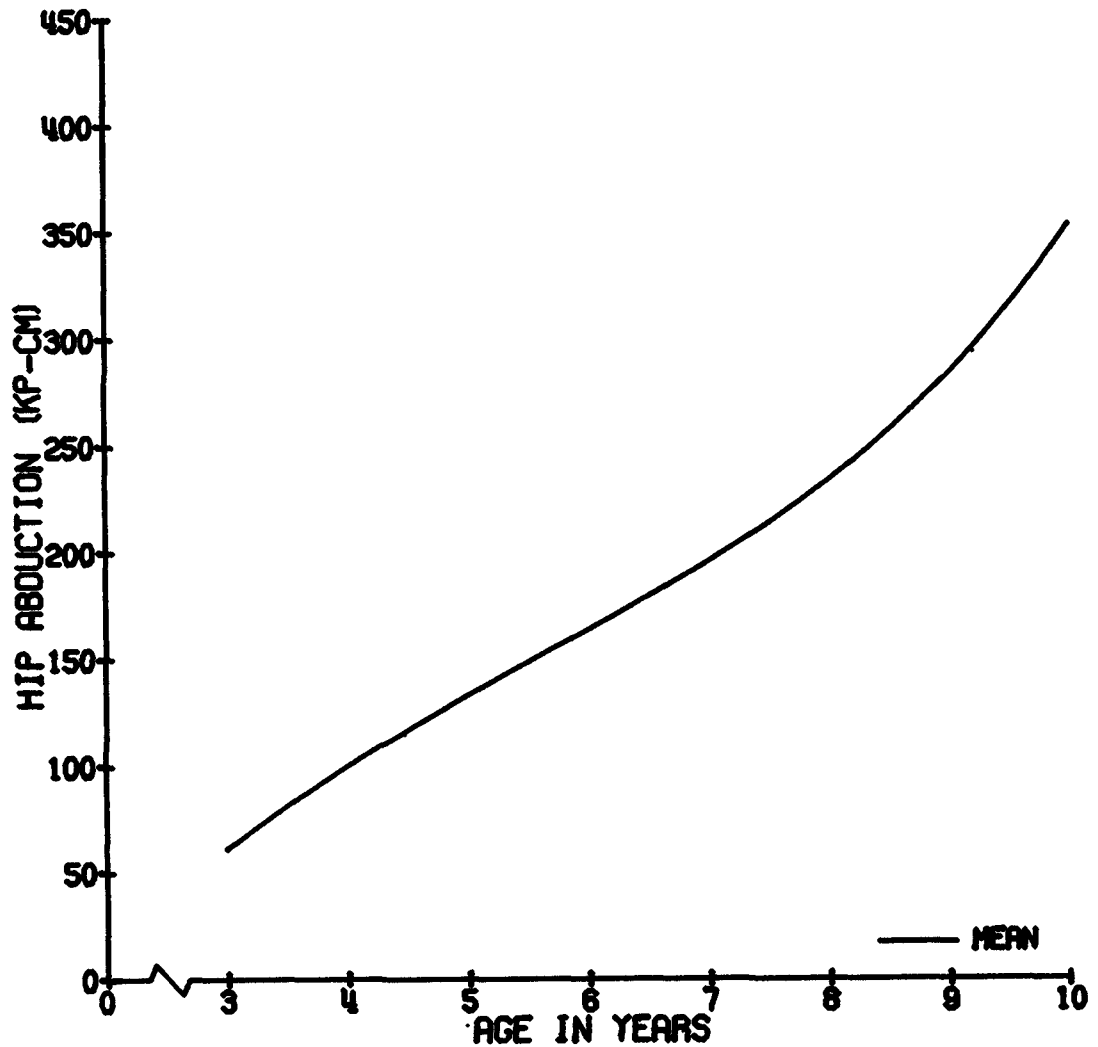

HIP ABDUCTION, 0 DEG. (KP-CM)

FEMALES

AGE	N	MEAN	ST. DEV	MIN	10%	MEDIAN	90%	MAX
3	2	51.2	29.1	30.7	30.7	51.2	71.8	71.8
4	18	103.5	35.7	48.2	52.9	98.5	148.3	172.2
5	23	125.2	37.8	49.6	79.7	119.6	166.1	209.8
6	23	135.6	36.9	52.8	85.9	139.0	174.9	209.6
7	18	175.7	39.8	116.7	127.9	169.4	261.2	262.0
8	12	261.4	93.4	86.0	144.4	270.7	366.0	382.7
9	19	269.3	76.0	113.2	124.5	284.4	352.8	410.2
10	8	308.0	70.4	179.3	179.3	324.1	389.0	389.0

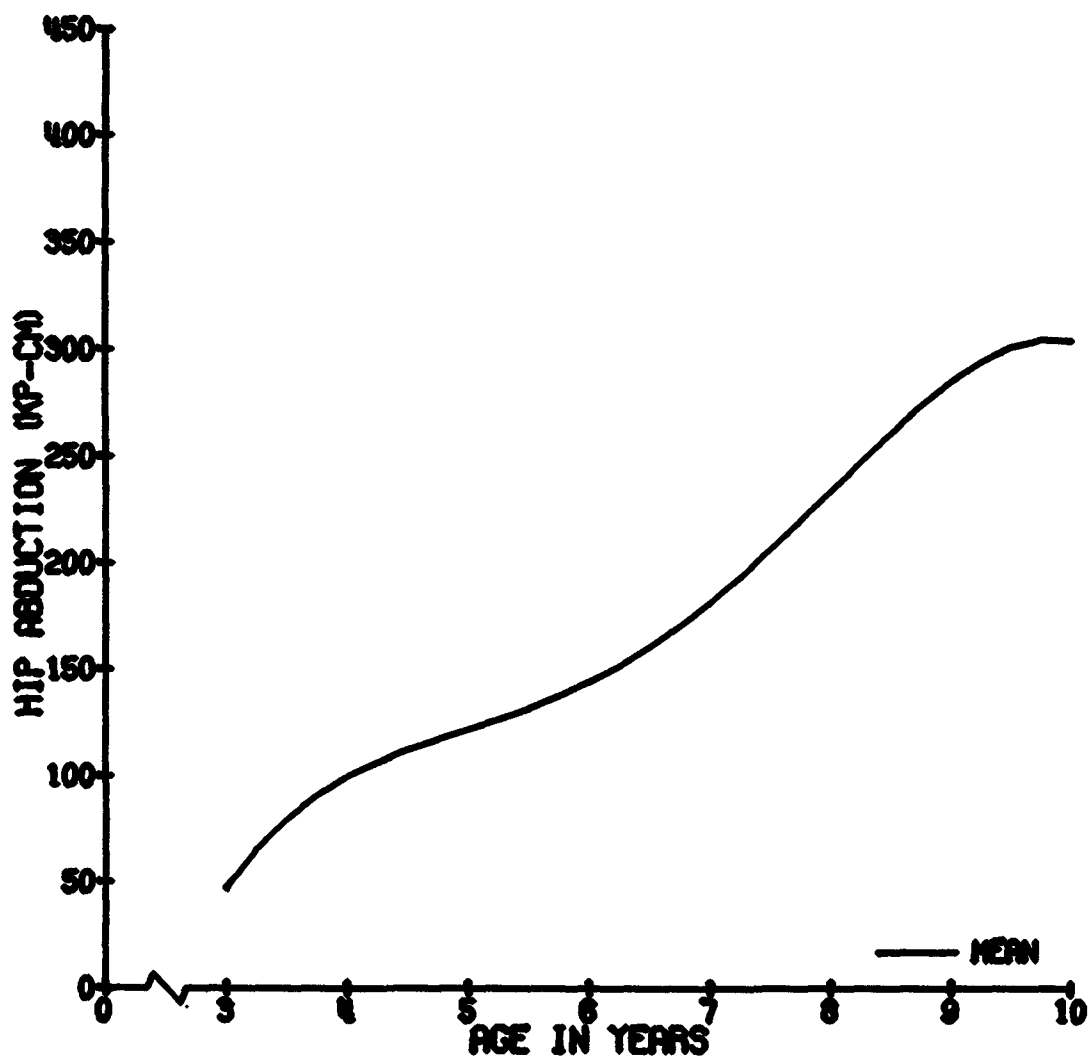

HIP MEDIAL ROTATION

DESCRIPTION OF TEST: The femur is rotated at the hip joint (femoral head) around its longitudinal axis, moving the anterior surface of the femur medially toward the midline of the body.

TEST POSITION: The hip is flexed 85° , the knee flexed 90° .

ANTHROPOMETRIC MEASUREMENTS: The femoral, tibial and tarsal linkages are measured with an anthropometer.

ADJUSTMENT OF EQUIPMENT: The chair leg fixtures are set to the femoral and tibial lengths, aligning the hip, knee and ankle joint centers with those of the chair. Thin rubber pads are placed under the leg to maintain these alignments. The hip flexion angle is locked at 85° and the knee flexion angle at 90° . The chest, pelvic, knee, foot and ankle straps are then secured snugly around the hips and right leg as well as the knee strap on the left leg. The left foot is free to rest on the left foot support.

INSTRUCTIONS TO SUBJECT: The child pushes his ankle to his right and his knee to his left.

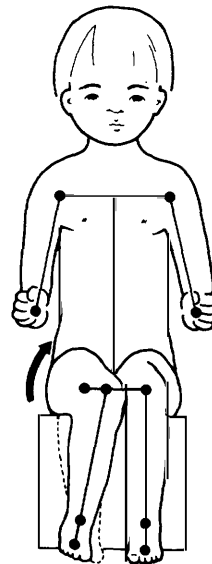
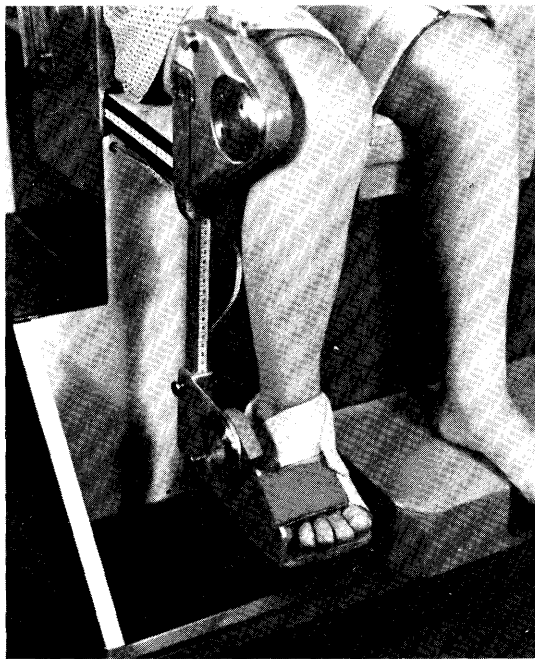

HIP MEDIAL ROTATION, 0 DEG. (KP-CM)

COMBINED SEXES

AGE	N	MEAN	ST. DEV	MIN	10%	MEDIAN	90%	MAX
3	8	32.8	19.1	5.5	5.5	28.9	57.3	57.3
4	35	39.5	18.6	6.2	17.9	34.9	68.6	87.3
5	30	53.8	19.4	24.4	29.3	47.6	83.2	100.6
6	41	74.5	33.5	21.9	40.6	68.6	115.7	189.5
7	31	95.1	42.9	22.3	57.2	90.8	133.9	233.3
8	31	119.4	42.9	65.9	74.8	119.1	183.4	220.2
9	32	159.7	65.0	36.2	90.1	144.4	255.8	268.6
10	15	168.9	65.3	77.0	82.7	170.6	263.6	268.0

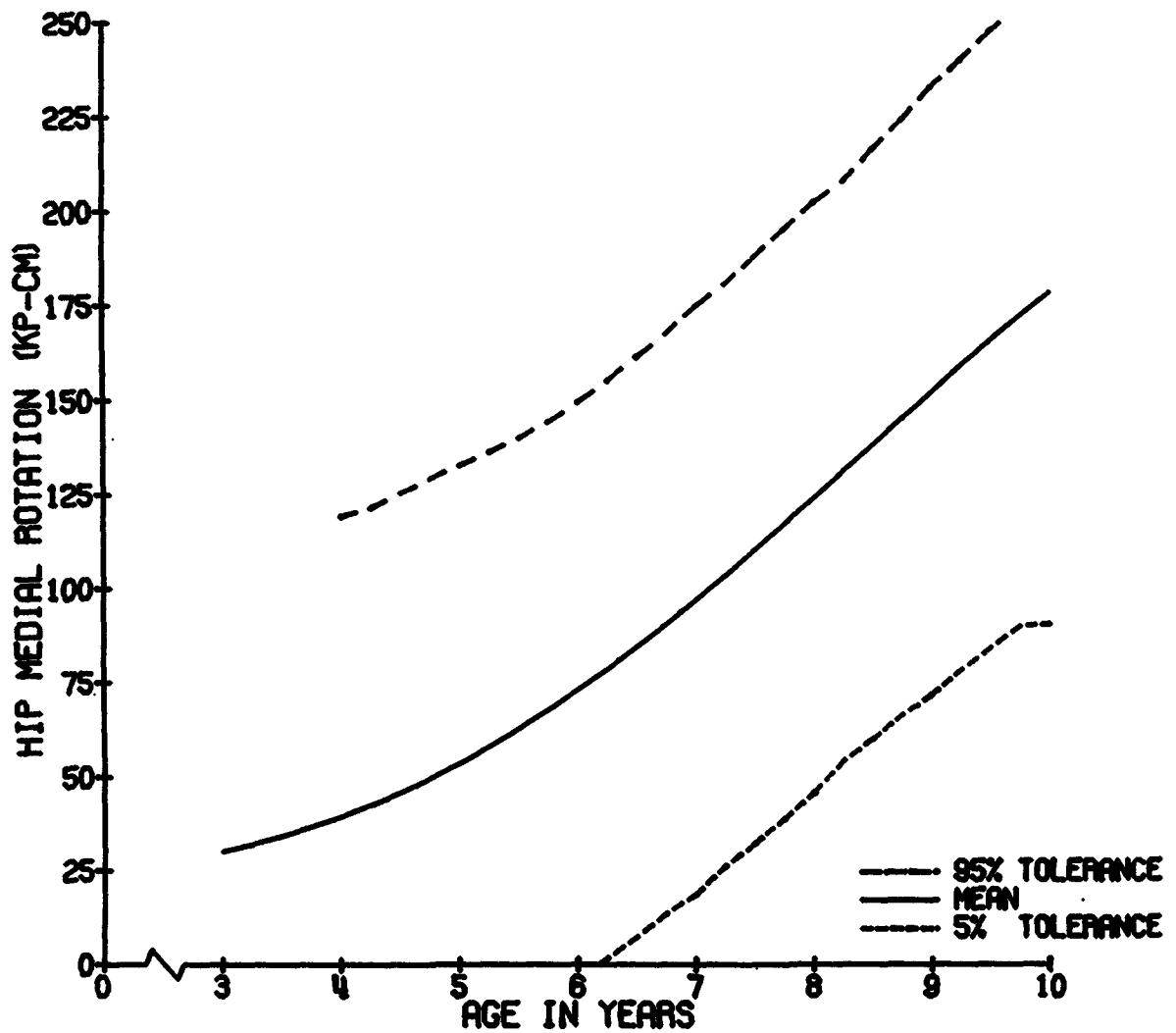

HIP MEDIAL ROTATION, ° DEG. (KP-CM)

MALES

AGE	N	MEAN	ST. DEV	MIN	10%	MEDIAN	90%	MAX
3	6	37.1	20.1	5.5	5.5	39.9	57.3	57.3
4	17	39.1	15.6	6.2	14.1	40.0	60.9	68.7
5	9	43.6	12.9	24.4	24.4	46.2	62.9	62.9
6	26	69.9	30.0	21.9	39.7	65.5	110.9	150.5
7	14	111.9	54.8	32.0	37.3	109.8	184.1	233.3
8	19	111.5	32.1	65.9	67.7	119.1	156.6	159.5
9	13	175.1	74.9	36.2	69.0	171.9	264.1	268.6
10	7	155.1	50.1	82.7	82.7	164.6	250.0	250.0

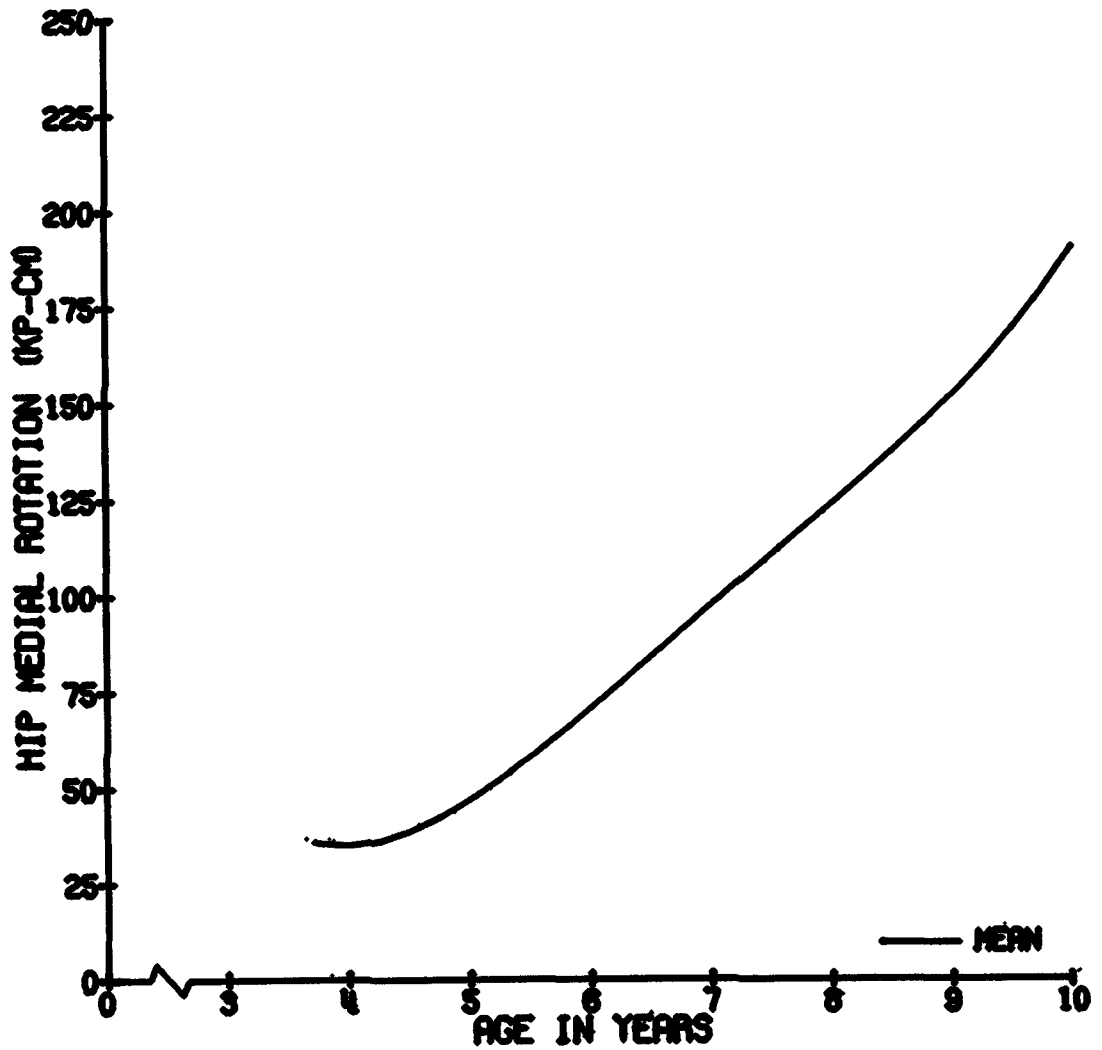

HIP MEDIAL ROTATION, 0 DEG. (KP-CM)

FEMALES

AGE	N	MEAN	ST. DEV	MIN	10%	MEDIAN	90%	MAX
3	2	19.9	9.4	13.3	13.3	19.9	26.6	26.6
4	18	39.9	21.5	12.1	17.9	30.2	72.1	87.3
5	21	58.1	20.4	29.3	33.3	50.9	84.2	100.6
6	15	82.5	38.7	33.2	43.2	72.8	120.5	189.5
7	17	81.3	23.6	22.3	57.2	87.3	110.4	116.5
9	12	131.8	55.4	74.8	75.0	115.4	209.4	220.2
9	19	149.1	57.0	57.3	90.1	140.6	242.6	255.8
10	8	181.0	71.9	77.0	77.0	185.6	268.0	268.0

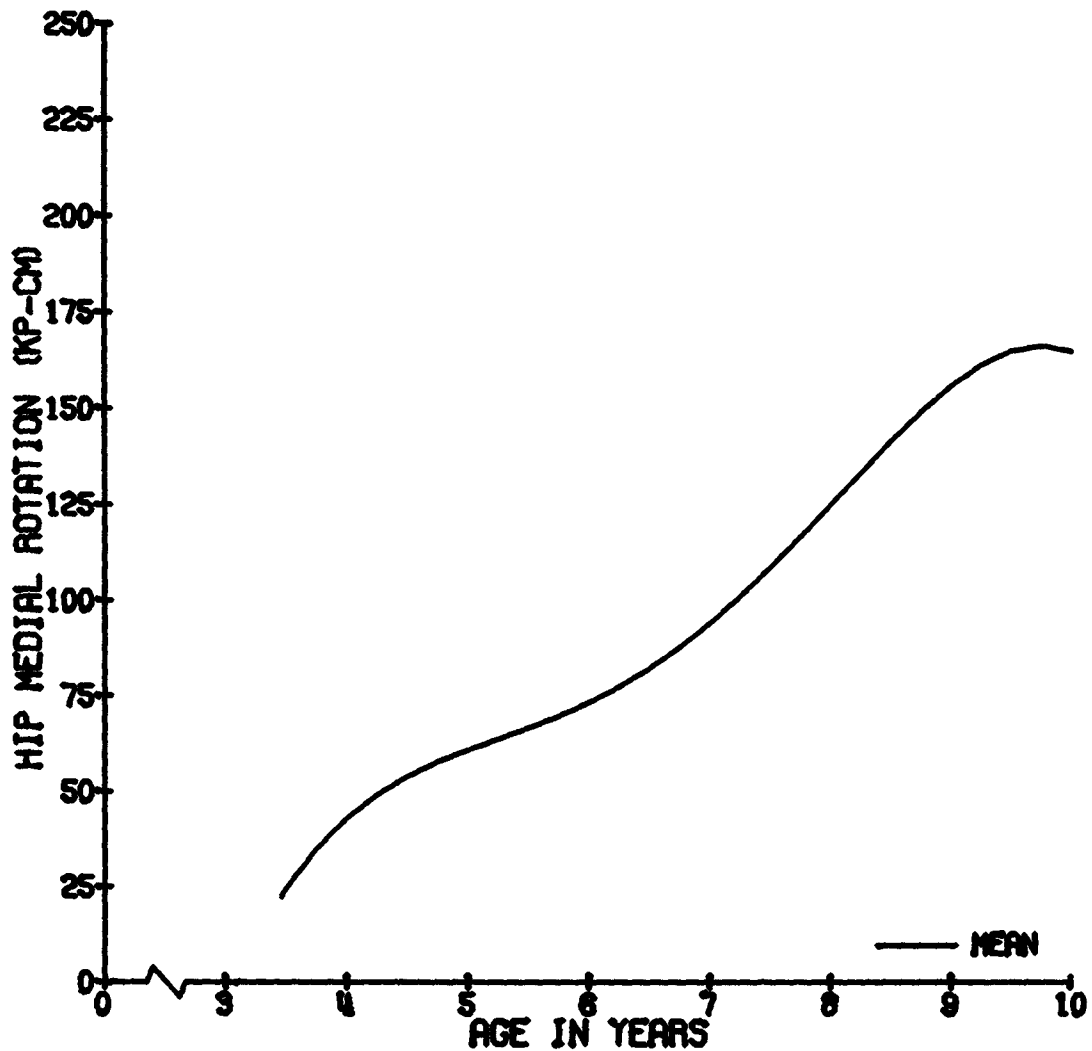

HIP LATERAL ROTATION

DESCRIPTION OF TEST: The femur is rotated at the hip joint (femoral head) around its longitudinal axis, moving the anterior surface of the femur laterally away from the midline of the body.

TEST POSITION: The hip is flexed 85° , the knee flexed 90° .

ANTHROPOMETRIC MEASUREMENTS: The femoral, tibial and tarsal linkages are measured with an anthropometer.

ADJUSTMENT OF EQUIPMENT: The chair leg fixtures are set to the femoral and tibial lengths, aligning the hip, knee and ankle joint centers with those of the chair. Thin rubber pads are placed under the leg to maintain these alignments. The hip flexion angle is locked at 85° and the knee flexion angle at 90° . The chest, pelvic, knee, foot and ankle straps are then secured snugly around the hips and right leg as well as the femoral strap on the left leg. The left foot is free to rest on the left foot support.

INSTRUCTIONS TO SUBJECT: The child pulls his ankle to his left and his knee to his right.

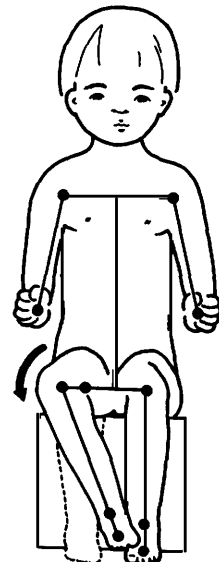

HIP LATERAL ROTATION,) DEG. (KP-CM)

COMBINED SEXES

AGE	N	MEAN	ST. DEV	MIN	10%	MEDIAN	90%	MAX
3	7	52.5	20.4	26.2	26.2	52.9	83.4	83.4
4	36	58.7	21.9	20.2	32.9	53.4	90.0	109.4
5	31	70.8	28.8	36.1	44.1	62.4	117.5	157.4
6	41	93.3	29.0	30.1	53.2	91.6	131.7	148.8
7	31	119.7	36.8	56.0	75.1	114.2	168.0	183.2
8	31	170.3	51.3	78.1	113.8	163.3	223.8	295.3
9	32	175.4	58.6	79.9	108.3	165.9	253.2	314.7
10	15	175.0	60.5	52.9	82.1	171.7	249.6	275.0

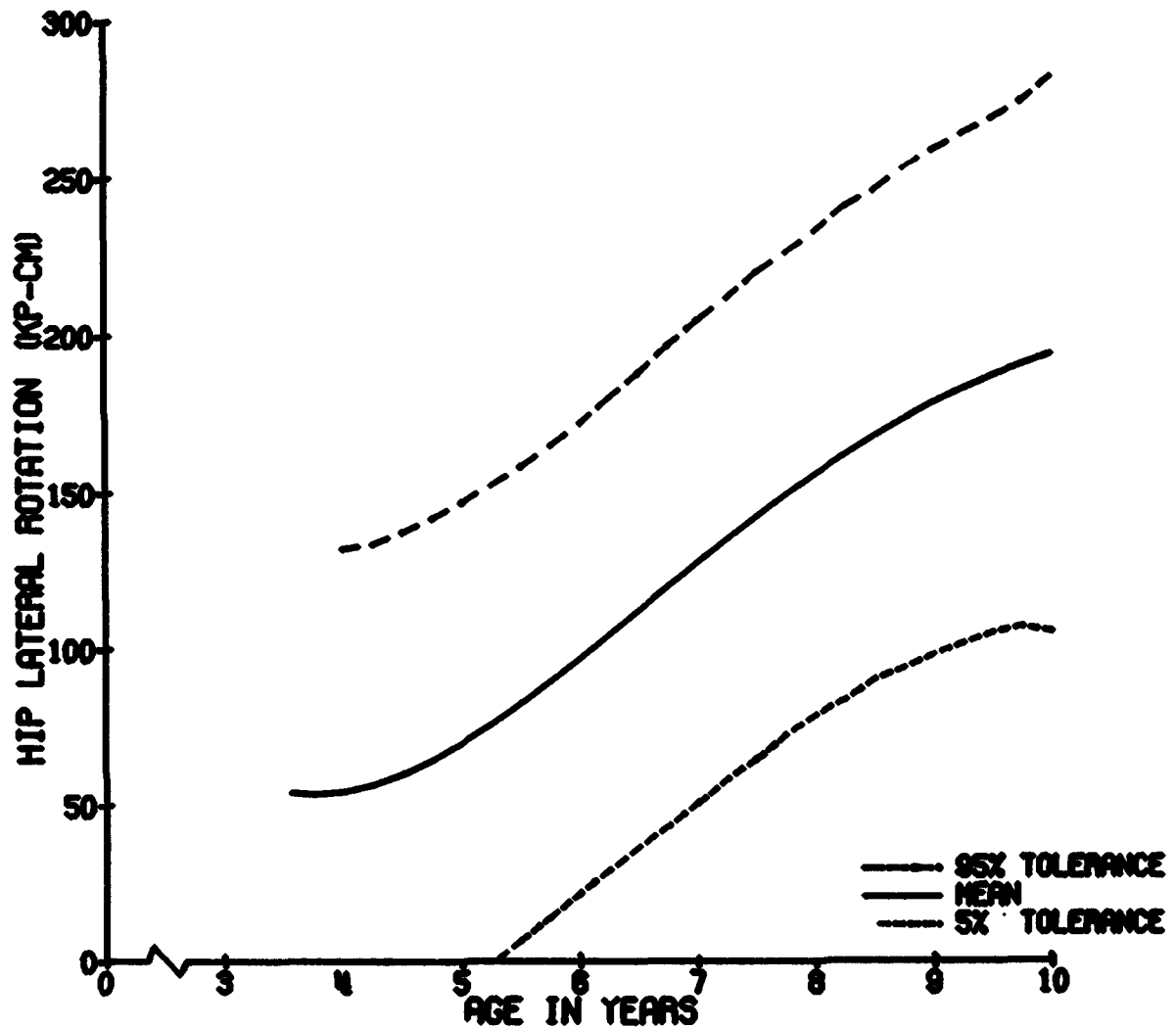

HIP LATERAL ROTATION, 0 DEG. (KP-CM)

MALES

AGE	N	MEAN	SF. DEV	MIN	10%	MEDIAN	90%	MAX
3	5	49.7	23.9	26.2	26.2	49.6	83.4	83.4
4	18	66.1	24.1	29.2	43.2	58.9	106.0	109.4
5	10	81.6	36.1	47.2	47.2	67.9	132.3	157.4
6	26	94.4	26.5	39.1	67.6	94.6	131.7	143.7
7	14	116.4	41.5	56.0	67.8	108.6	168.0	183.2
8	19	179.6	50.3	113.8	129.2	163.3	288.1	295.3
9	13	207.7	61.7	115.4	115.8	204.2	293.7	314.7
10	7	204.0	47.4	147.4	147.4	193.0	275.0	275.0

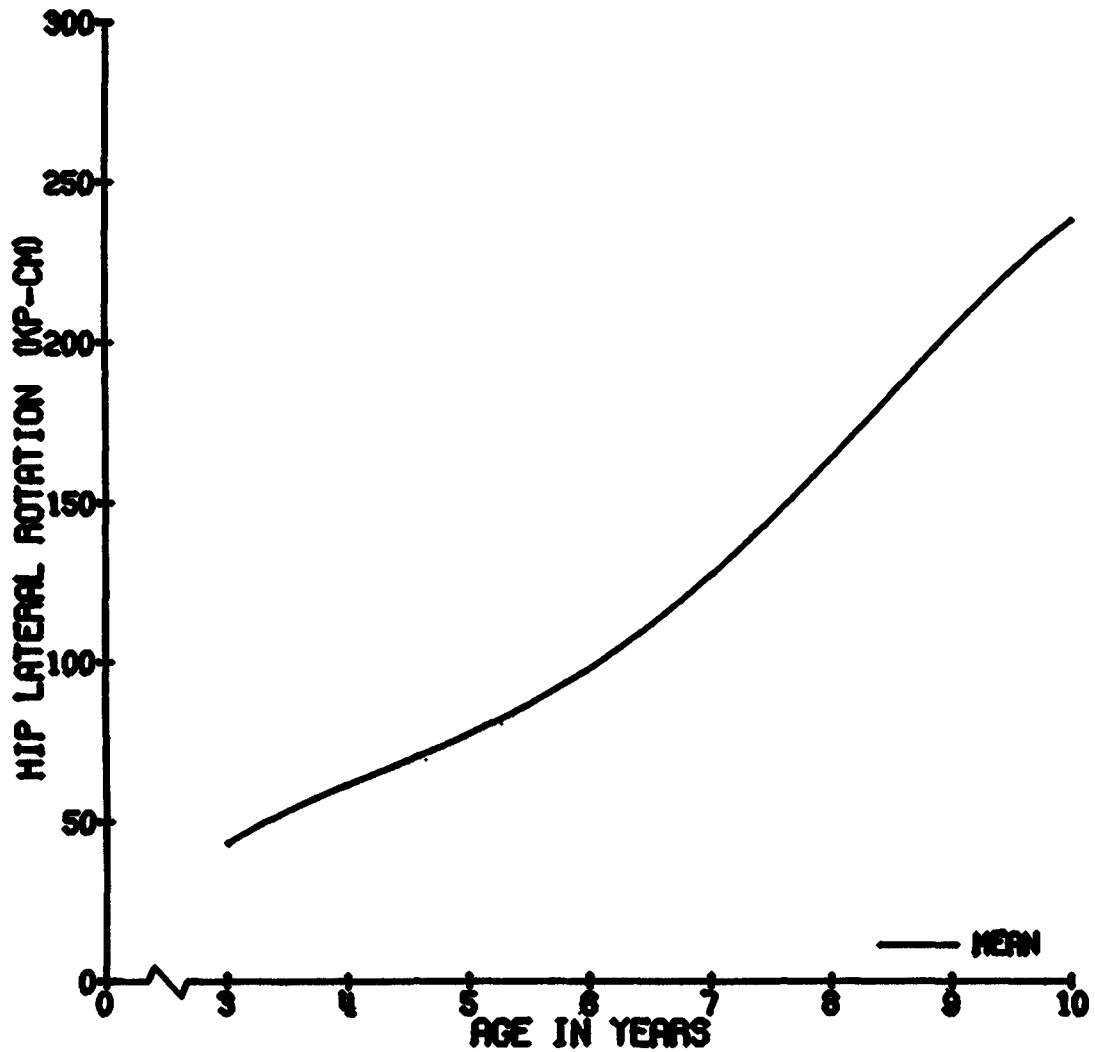

HIP LATERAL ROTATION, 0 DEG. (KP-CM)

FEMALES

AGE	N	MEAN	ST. DEV	MIN	10%	MEDIAN	90%	MAX
3	2	59.5	9.3	52.9	52.9	59.5	66.1	66.1
4	18	49.9	16.3	29.8	30.9	44.9	79.1	84.7
5	21	65.6	23.9	36.1	40.4	55.1	87.5	118.2
6	15	92.8	33.9	34.2	51.7	89.1	132.5	148.8
7	17	122.4	33.5	75.1	84.1	127.4	176.5	179.5
8	12	155.5	51.3	78.1	80.9	167.0	214.5	223.8
9	19	153.2	45.8	79.9	84.6	155.4	213.7	253.2
10	8	149.5	61.7	52.9	52.9	153.1	231.5	231.5

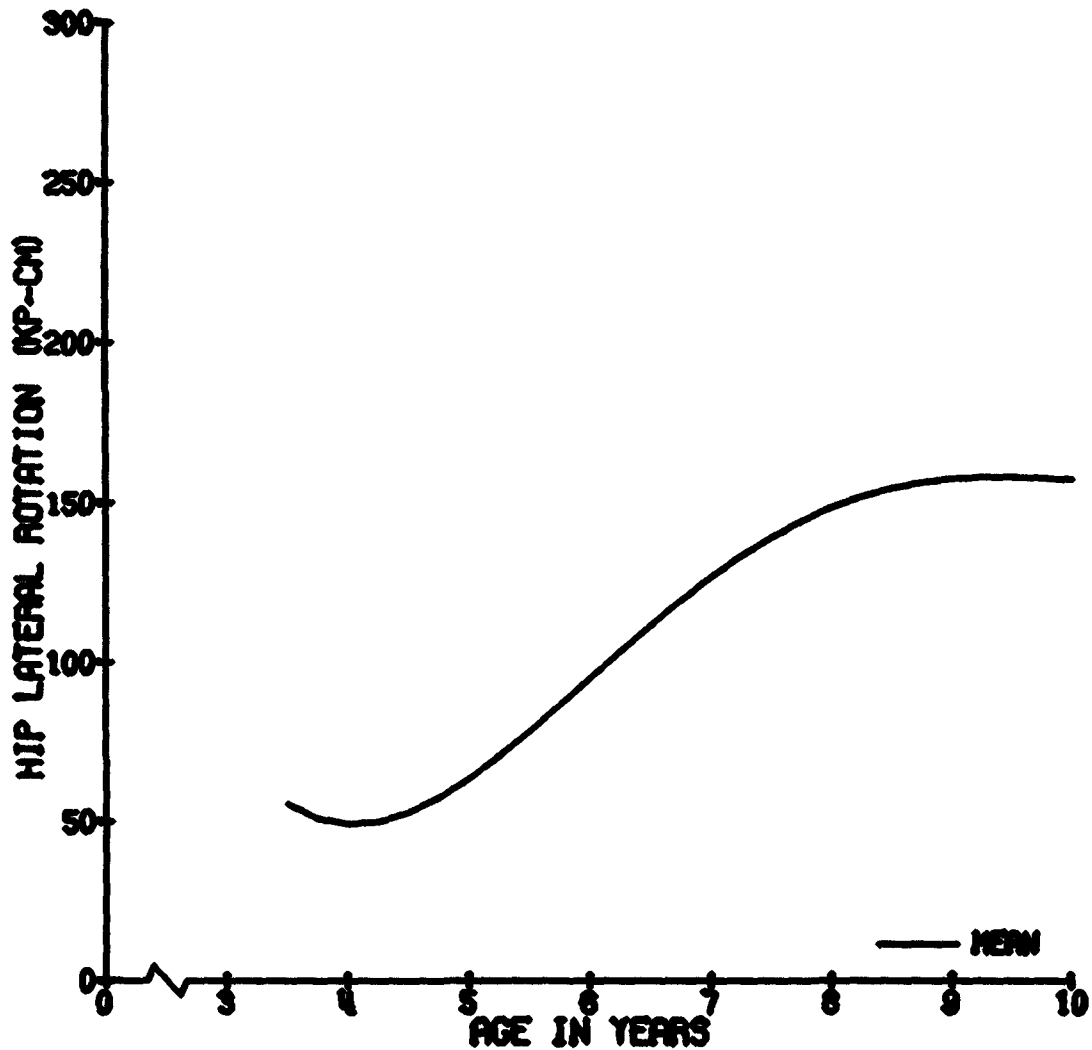

TORSO FLEXION

DESCRIPTION OF TEST: The thoracolumbar vertebral column is rotated anteriorly at the sacroiliac joint in the saggital plane.

TEST POSITION: The right shoulder is abducted 5° , both the left and right elbows flexed 90° , hip flexed at 85° and both knees flexed at 90° .

ANTHROPOMETRIC MEASUREMENTS: The thoracolumbar, sacral and femoral linkage measurements are taken with an anthropometer.

ADJUSTMENT OF EQUIPMENT: The chair back is set to the sacral plus thoracolumbar lengths, aligning the shoulder and hip joint centers with those of the chair. The chair leg fixtures are set to the femoral and tibial lengths, aligning the knee and ankle joint centers with those of the chair. Thin rubber pads are placed under the torso to maintain these alignments. The hip flexion angle is locked at 85° . The arm, chest and knee straps are secured snugly around the trunk and extremities. The head and neck are left free to flex anteriorly.

INSTRUCTIONS TO SUBJECT: The child pulls his chest forward, bending at his waist.

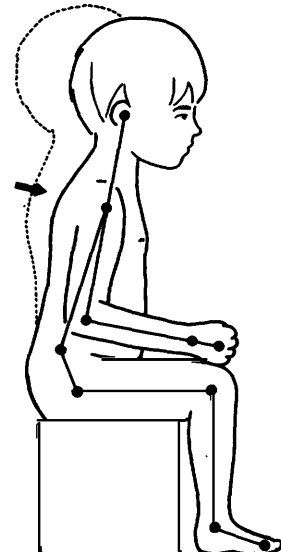

TRUNK FLEXION, 0 DEG. (KP-CM)

COMBINED SEXES

AGE	N	MEAN	ST. DEV	MIN	10%	MEDIAN	90%	MAX
3	9	99.5	21.0	77.4	77.4	95.5	144.4	144.4
4	37	131.2	48.6	35.9	71.5	129.9	197.1	266.1
5	30	167.6	52.6	78.1	91.9	165.7	228.6	289.0
6	45	224.5	60.1	92.0	160.2	220.5	308.0	360.6
7	78	288.2	85.2	86.8	166.2	281.4	398.8	498.8
8	71	357.5	105.5	116.6	247.2	350.3	512.2	726.3
9	80	379.7	122.8	167.9	230.9	376.2	547.5	671.3
10	28	442.8	107.2	194.4	235.9	468.5	546.3	627.7

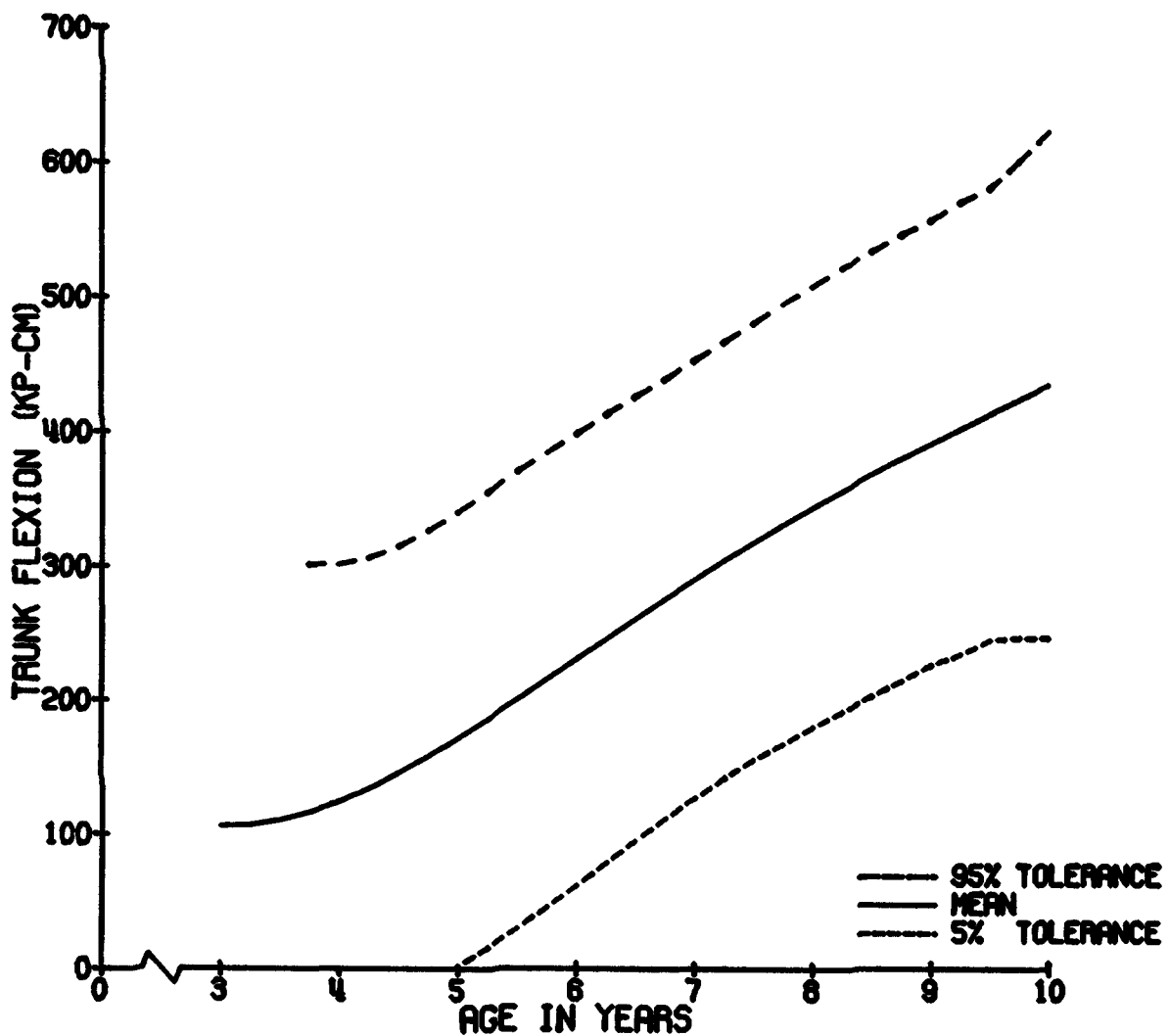

TRUNK FLEXION, 0 DEG. (KP-CM)

MALES

AGE	N	MEAN	ST. DEV	MIN	10%	MEDIAN	90%	MAX
3	7	102.4	22.3	77.7	77.7	95.5	144.4	144.4
4	19	135.9	44.2	35.9	80.9	142.2	197.9	205.3
5	9	166.8	69.5	87.7	87.7	131.9	289.0	289.0
6	27	228.5	60.7	92.0	164.1	230.2	325.2	360.6
7	35	285.2	83.4	135.7	186.4	280.1	382.1	470.7
8	37	361.2	87.8	195.6	253.3	355.4	483.3	585.3
9	37	427.9	111.7	194.7	272.7	435.8	581.0	671.3
10	16	466.1	99.2	194.4	354.3	482.9	556.4	627.7

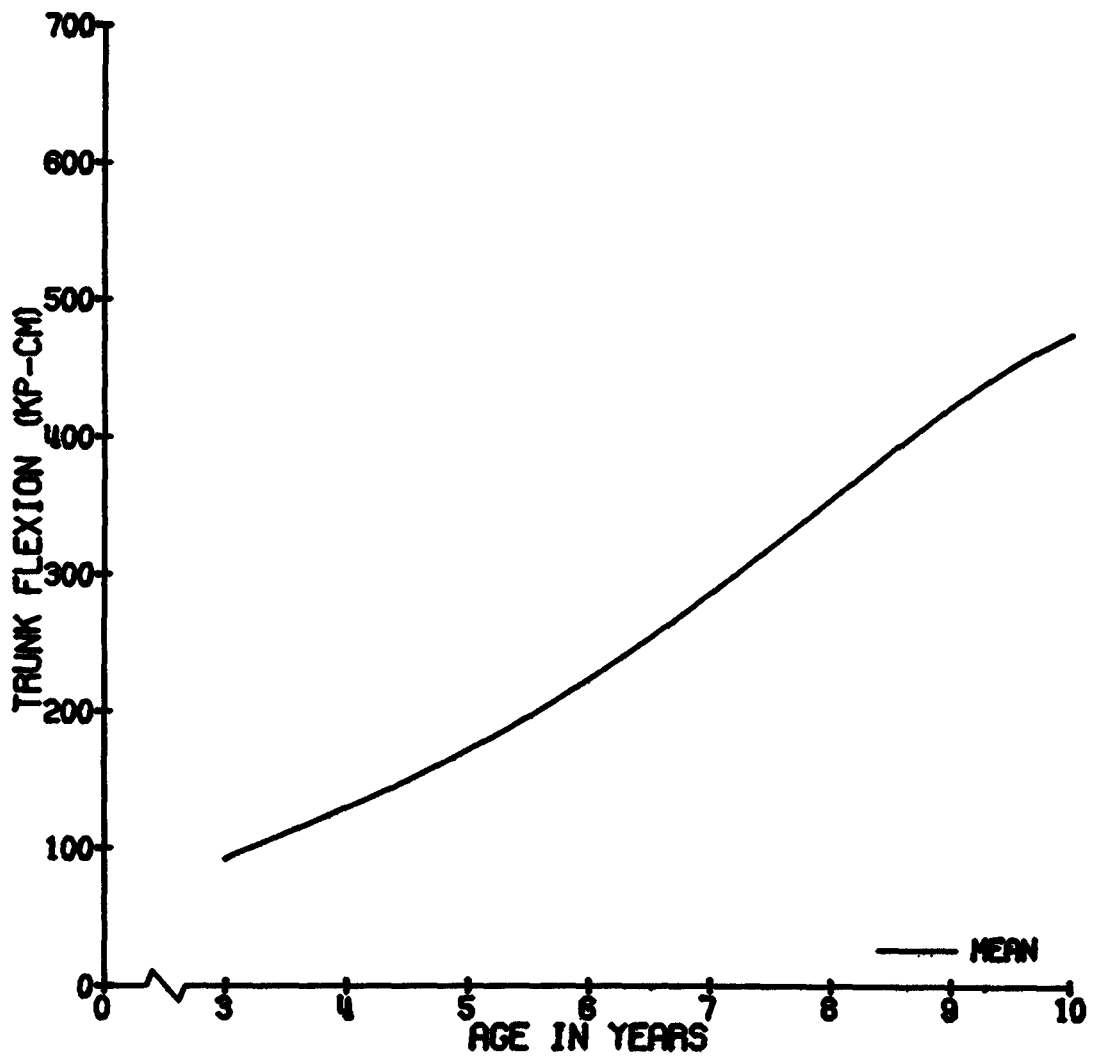

TRUNK FLEXION, J DEG. (KP-CM)

FEMALES

AGE	N	MEAN	ST. DEV	MIN	10%	MEDIAN	90%	MAX
3	2	89.1	16.6	77.4	77.4	89.1	100.9	100.9
4	18	126.1	53.6	58.1	67.0	124.3	197.1	266.1
5	21	169.0	45.6	78.1	109.2	174.0	227.1	235.3
6	18	218.5	60.3	126.9	142.0	211.8	305.4	320.4
7	43	290.7	87.5	86.8	166.2	290.0	398.8	498.8
8	34	353.4	123.2	116.6	201.0	341.3	516.0	726.3
9	43	338.2	117.7	167.9	211.9	297.4	512.0	626.7
10	12	411.7	113.9	229.5	235.9	425.7	543.5	546.3

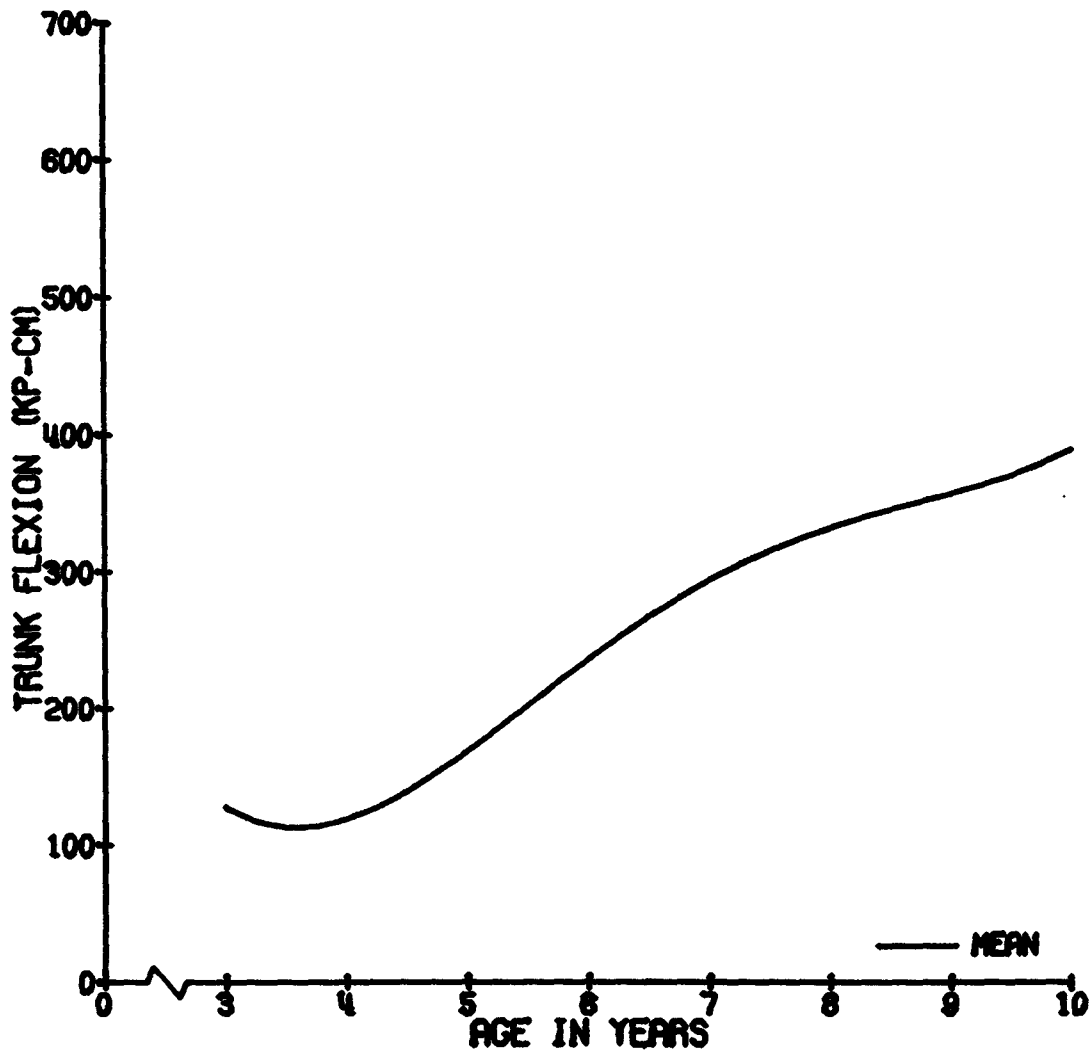

TORSO EXTENSION

DESCRIPTION OF TEST: The thoracolumbar vertebral column is rotated posteriorly at the sacroiliac joint in the saggital plane.

TEST POSITION: The right shoulder is abducted 5° , both the left and right elbows flexed 90° , hip flexed 85° and both knees flexed at 90° .

ANTHROPOMETRIC MEASUREMENTS: The thoracolumbar, sacral, and femoral linkage measurements are taken with an anthropometer.

ADJUSTMENT OF EQUIPMENT: The chair back is set to the sacral plus thoracolumbar lengths, aligning the shoulder and hip joint centers with those of the chair. The chair leg fixtures are set to the femoral and tibial lengths, aligning the knee and ankle joint centers with those of the chair. Thin rubber pads are placed under the torso to maintain these alignments. The hip flexion angle is locked at 85° . The arm, chest and knee straps are secured snugly around the trunk and extremities. The head and neck are left free to flex anteriorly.

INSTRUCTIONS TO SUBJECT: The child pushes his back rearward, bending at his waist.

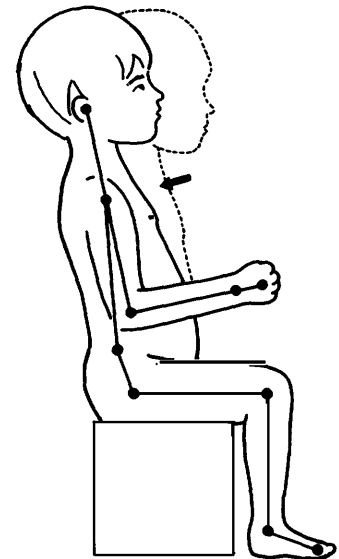

TRUNK EXTENSION, ° DEG. (KP-CM)

COMBINED SEXES

AGE	N	MEAN	3T. DEV	MIN	10%	MEDIAN	90%	MAX
3	12	89.9	55.5	2.1	24.8	87.3	166.6	181.3
4	61	132.2	80.2	30.3	50.6	118.1	239.3	484.4
5	63	156.5	74.1	21.4	65.7	151.0	238.6	420.5
6	57	182.7	83.3	36.9	105.9	173.2	285.2	530.4
7	78	242.6	110.5	70.9	121.5	206.5	420.1	590.9
8	71	310.1	105.8	76.6	204.1	289.7	436.1	647.0
9	81	347.4	129.1	107.7	198.0	338.1	526.1	701.6
10	28	418.5	137.6	127.0	242.5	440.1	583.4	712.4

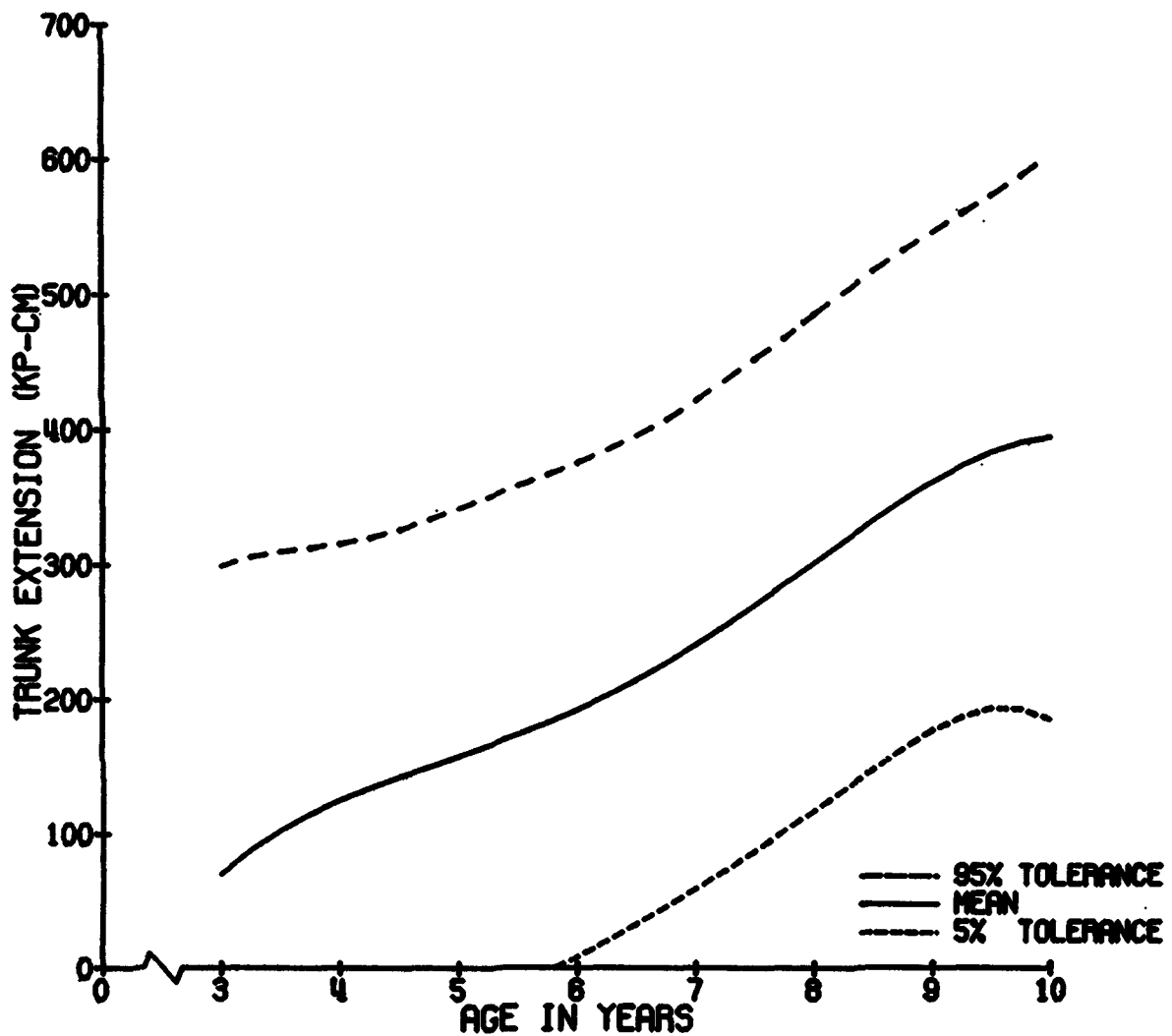

TRUNK EXTENSION, J DEG. (KP-CM)

MALES

AGE	N	MEAN	ST. DEV	MIN	10%	MEDIAN	90%	MAX
3	8	94.3	54.9	24.8	24.8	87.3	181.3	181.3
4	27	140.5	93.8	48.3	61.2	121.0	240.6	484.4
5	24	176.8	88.5	21.4	106.3	154.5	313.7	420.5
6	32	188.1	95.7	63.5	78.6	166.4	308.8	530.4
7	35	252.2	111.1	76.5	117.4	234.4	426.1	458.0
8	37	310.6	111.6	100.9	210.4	287.2	436.1	647.0
9	39	387.1	121.7	158.5	230.2	364.1	530.6	701.6
10	10	442.9	143.8	127.0	186.5	471.5	583.4	712.4

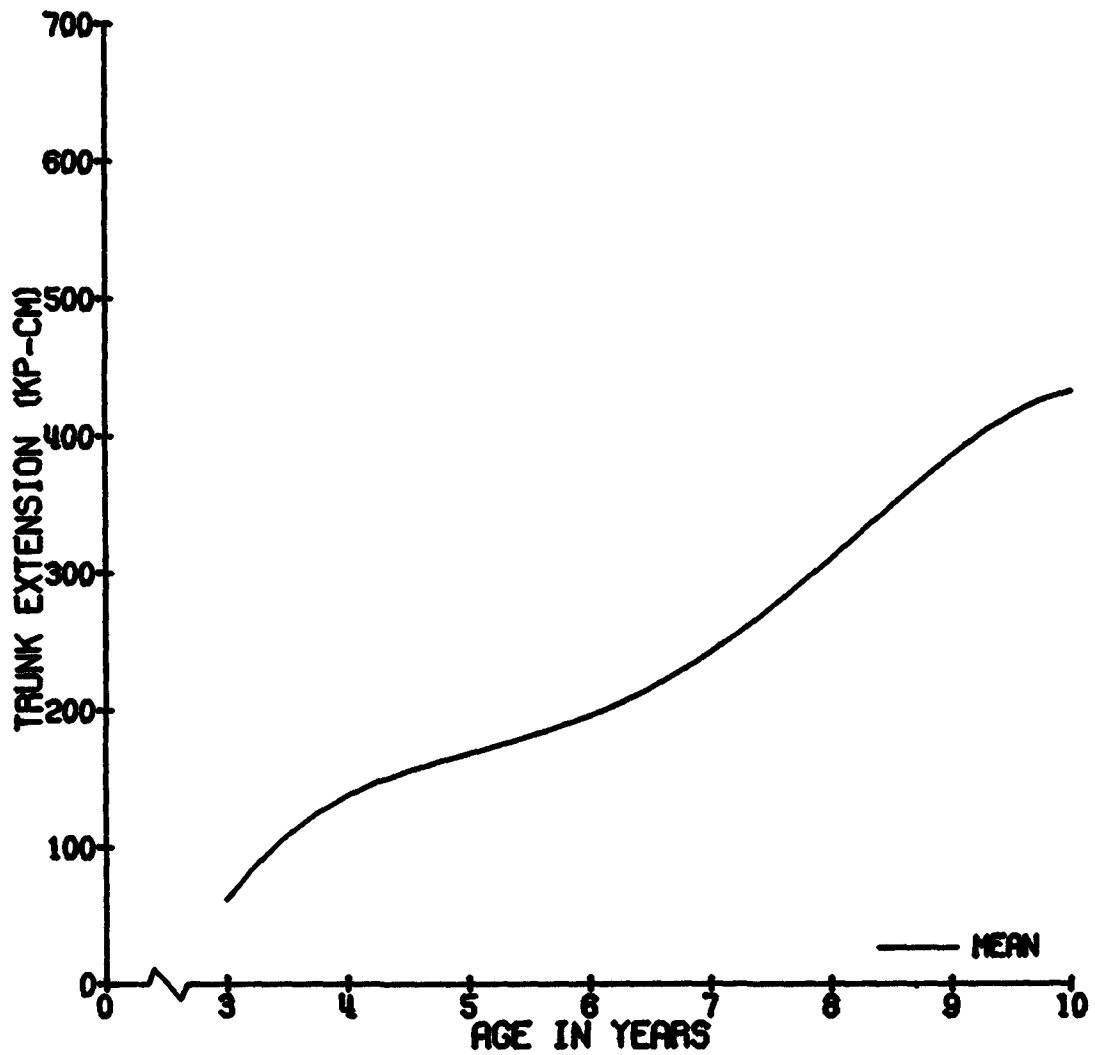

TRUNK EXTENSION, ° DEG. (KP-CM)

FEMALES

AGE	N	MEAN	ST. DEV	MIN	10%	MEDIAN	90%	MAX
3	4	78.8	63.7	2.1	2.1	90.5	131.9	131.9
4	34	125.5	68.3	30.3	44.7	114.4	239.3	309.8
5	39	144.0	61.7	51.0	61.9	151.0	228.4	288.6
6	25	175.7	65.3	36.9	109.9	177.6	252.9	378.3
7	43	234.8	110.7	70.9	128.2	198.1	379.7	590.9
8	34	309.6	100.8	76.6	199.0	306.6	441.7	526.3
9	43	312.3	126.7	107.7	163.8	310.6	474.5	655.4
10	12	386.0	117.6	242.5	246.4	350.4	506.9	634.6

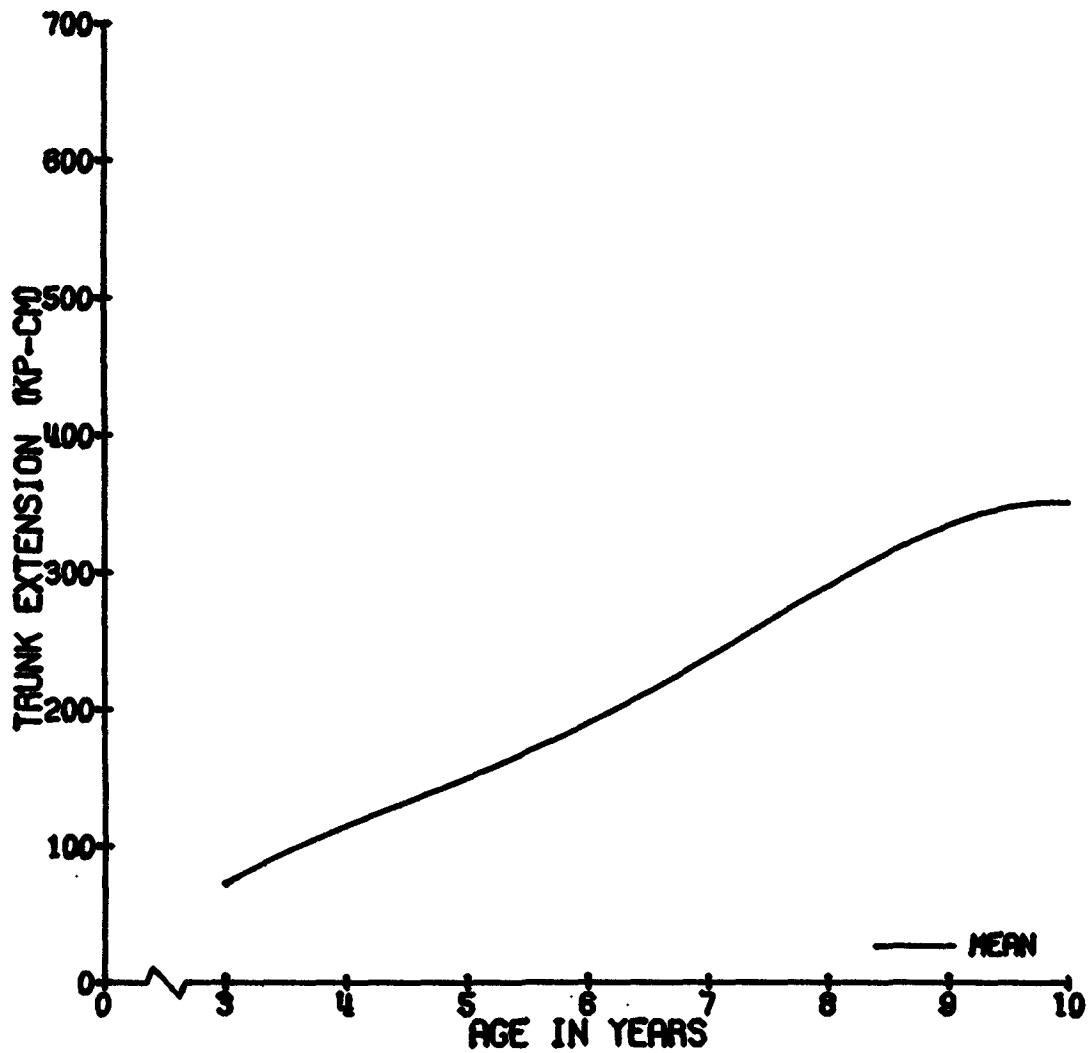

GRIP: TWO-POINT PINCH

DESCRIPTION OF TEST: The anterior surface of the first finger (distal end of phalanx #2) is pressed in opposition to the anterior surface of the thumb tip (distal end of phalanx #1)

TEST POSITION: The thumb and first finger are flexed in a plane parallel to the saggital plane so that the thumb tip is opposite the first finger tip. The remaining three fingers are flexed in the same plane into a tight fist. The anterior surface of the thumb tip clears the anterior surface of the first finger by 20 mm (see below).

ANTHROPOMETRIC MEASUREMENTS: None

ADJUSTMENT OF EQUIPMENT: The finger plates of the grip transducer are set 20 mm apart.

INSTRUCTIONS TO SUBJECT: The child makes a fist and pinches the two plates together using his thumb and first finger.

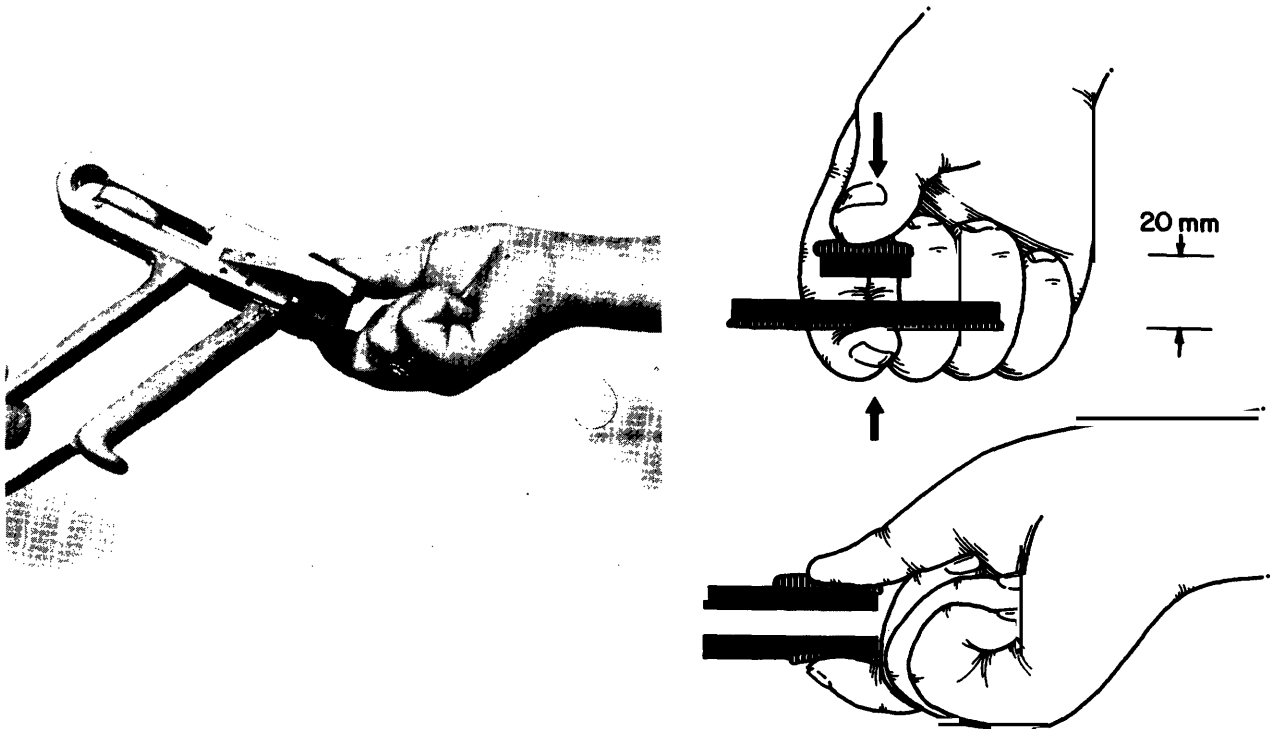

GRIP - 2 POINT PINCH (KP)

COMBINED SEXES

AGE	N	MEAN	ST. DEV	MIN	10%	MEDIAN	90%	MAX
3	7	1.2	0.4	0.9	0.9	1.1	2.1	2.1
4	36	1.6	0.5	0.9	1.0	1.5	2.2	3.0
5	31	1.8	0.5	1.0	1.2	1.7	2.5	3.4
6	41	2.2	0.6	1.2	1.6	2.0	3.0	3.6
7	31	2.5	0.5	1.6	1.9	2.5	3.0	3.4
8	31	3.0	0.7	1.8	2.3	2.9	4.1	4.5
9	32	3.2	0.8	2.0	2.4	3.0	4.2	5.2
10	15	3.1	0.8	2.2	2.3	2.7	4.3	4.8

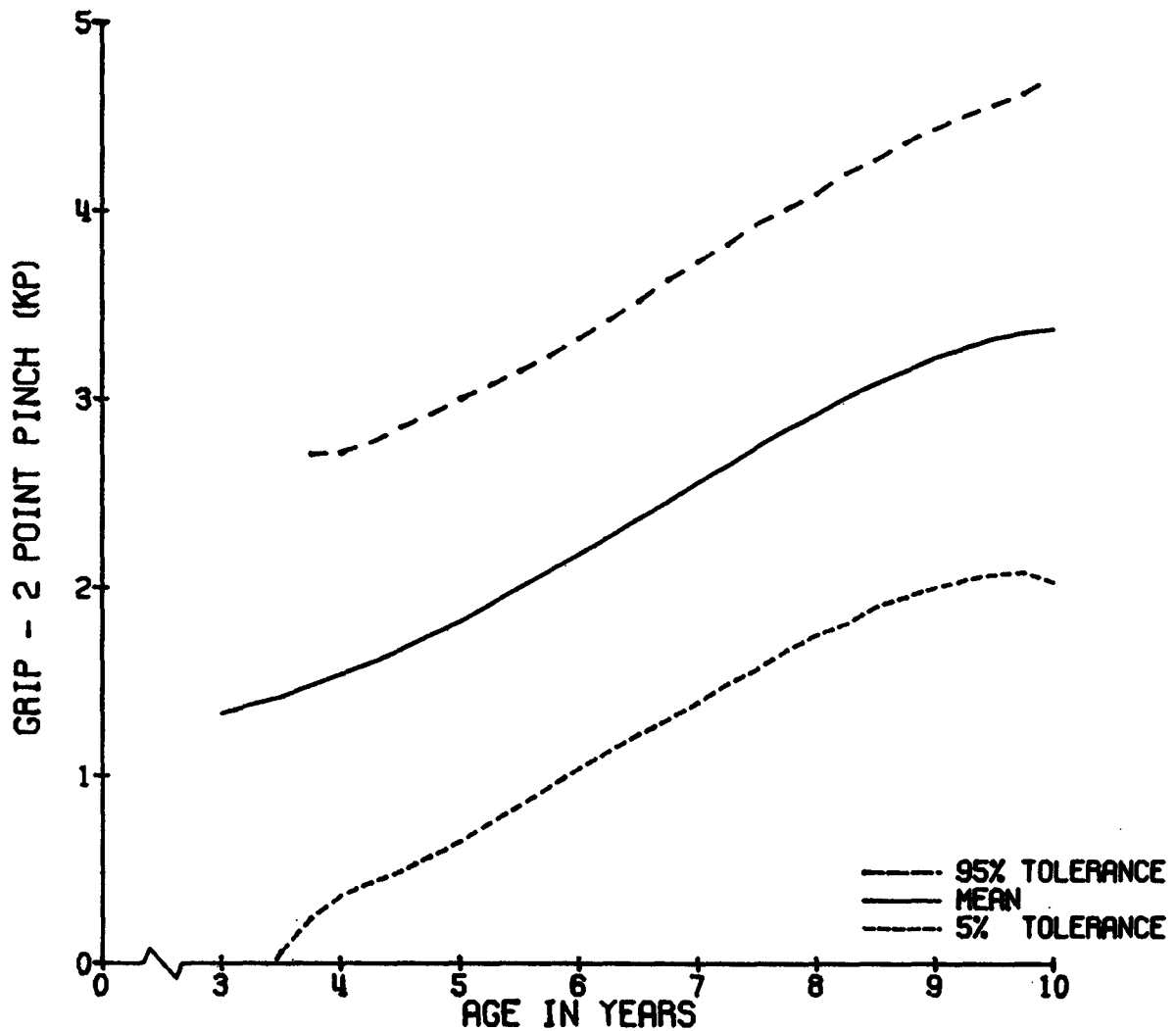

GRIP - 2 POINT PINCH (KP)

MALES

AGE	n	MEAN	ST. DEV	MIN	10%	MEDIAN	90%	MAX
3	5	1.3	0.5	0.9	0.9	1.1	2.1	2.1
4	18	1.8	0.5	1.0	1.1	1.8	2.4	3.0
5	10	1.8	0.7	1.1	1.1	1.6	2.5	3.4
6	26	2.3	0.6	1.2	1.6	2.0	3.1	3.6
7	14	2.5	0.5	1.6	1.7	2.7	3.0	3.0
8	19	3.2	0.6	2.1	2.4	3.0	4.1	4.5
9	13	3.6	1.0	2.0	2.5	4.0	4.9	5.2
10	7	3.3	0.8	2.4	2.4	3.7	4.3	4.3

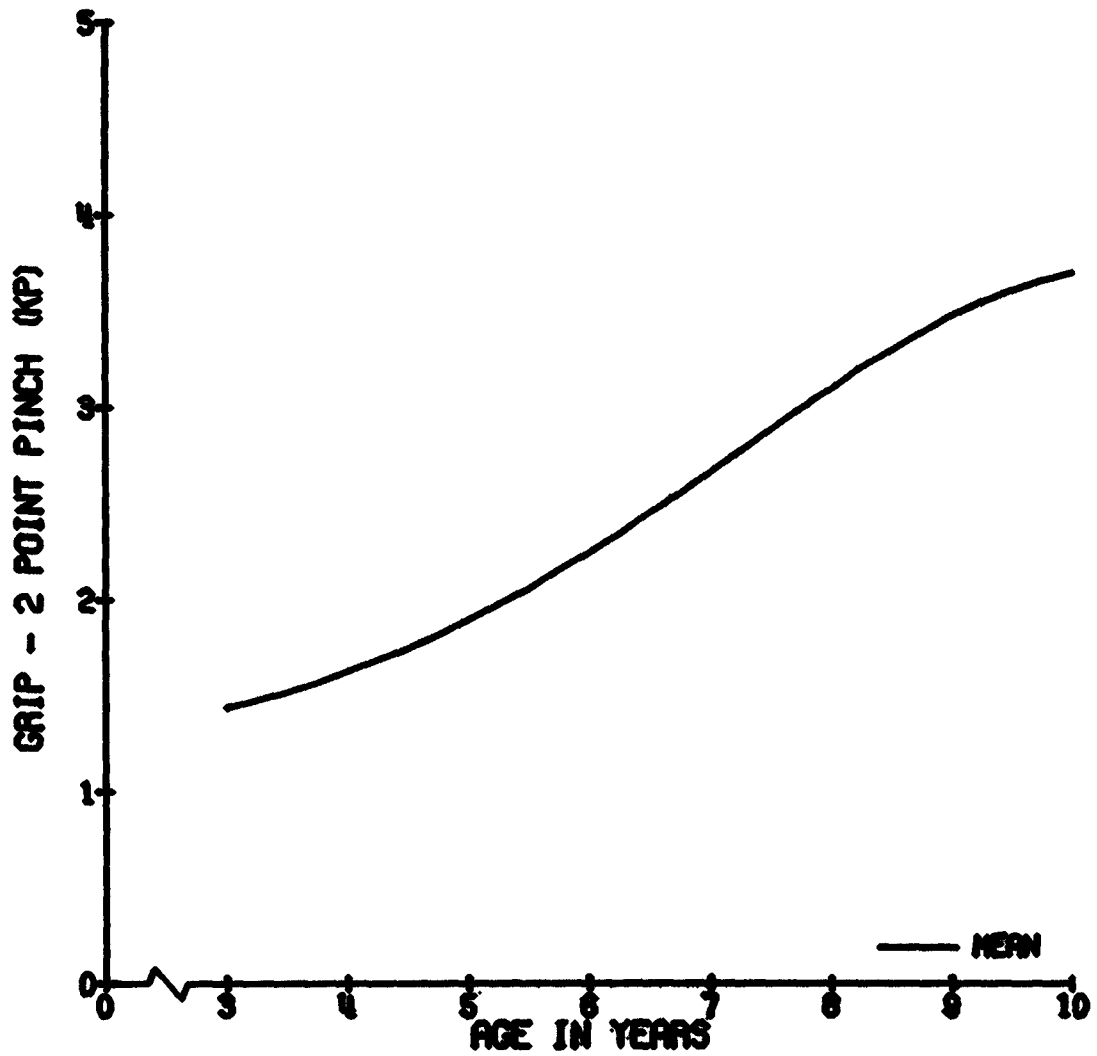

GRIP - 2 POINT PINCH (KP)

FEMALES

AGE	N	MEAN	ST. DEV	MIN	10%	MEDIAN	90%	MAX
3	2	1.0	0.1	0.9	0.9	1.0	1.1	1.1
4	18	1.5	0.4	0.9	0.9	1.4	2.2	2.2
5	21	1.7	0.5	1.0	1.2	1.8	2.4	2.8
6	15	2.1	0.5	1.3	1.6	2.0	2.6	3.1
7	17	2.4	0.5	1.8	1.9	2.2	3.4	3.4
8	12	2.8	0.8	1.8	2.0	2.5	3.8	4.5
9	19	3.1	0.6	2.1	2.2	2.8	3.9	4.2
10	6	3.9	0.9	2.2	2.2	2.7	4.8	4.8

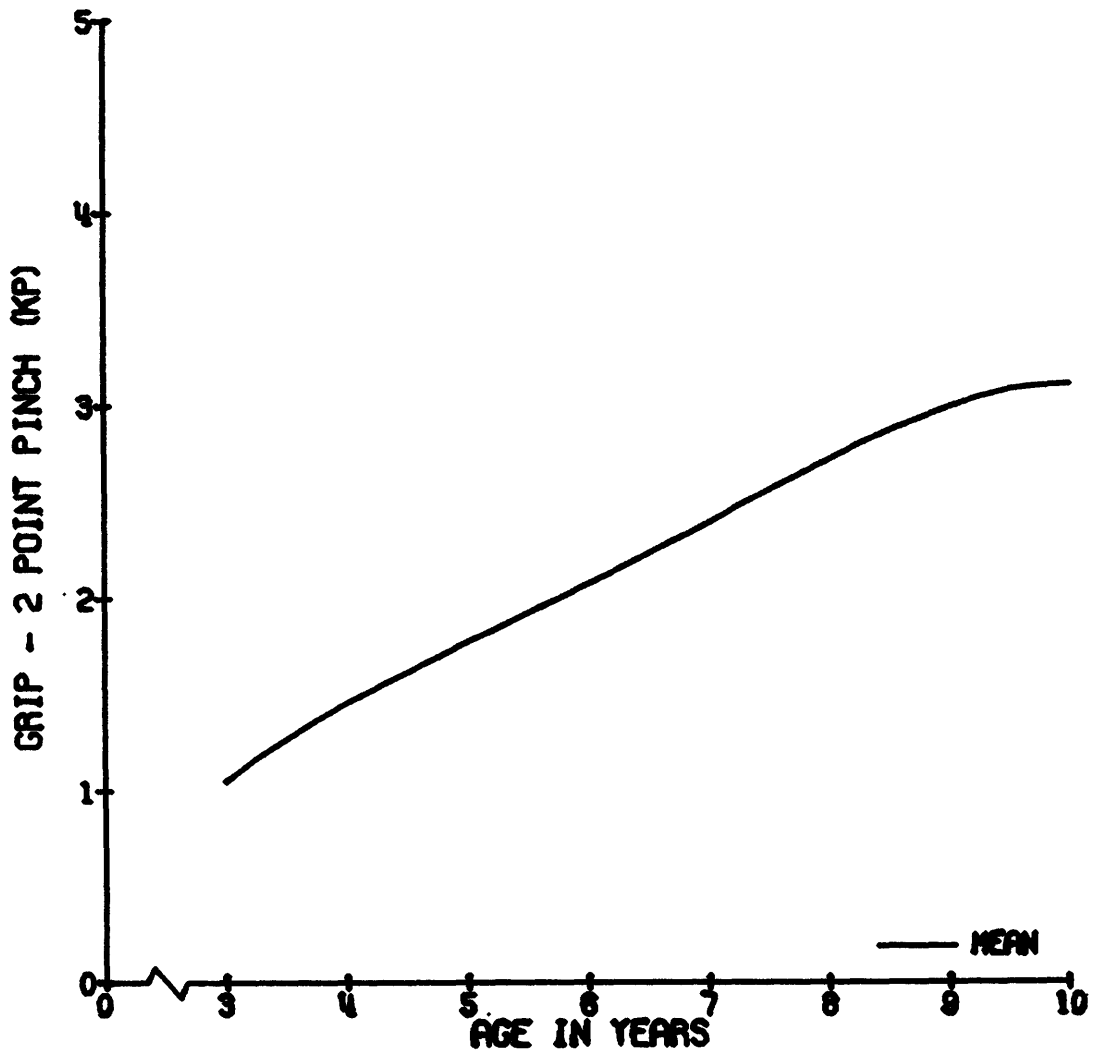

GRIP: THREE-POINT PINCH

DESCRIPTION OF TEST: The anterior surface of the first two fingers (distal end of phalanges #2 and #3) are pressed in opposition to the anterior surface of the thumb tip (distal end of phalanx #1).

TEST POSITION: The thumb and first two fingers are flexed in a plane parallel to the saggital plane so that the thumb tip is opposite the first and second finger tips. The remaining two fingers are flexed in the same plane into a tight fist. The anterior surface of the thumb tip clears the anterior surface of the first two finger tips by 20 mm (see below).

ANTHROPOMETRIC MEASUREMENTS: None

ADJUSTMENT OF EQUIPMENT: The finger plates of the grip transducer are set 20 mm apart.

INSTRUCTIONS TO SUBJECT: The child makes a fist and pinches the two plates together using his thumb and first two fingers.

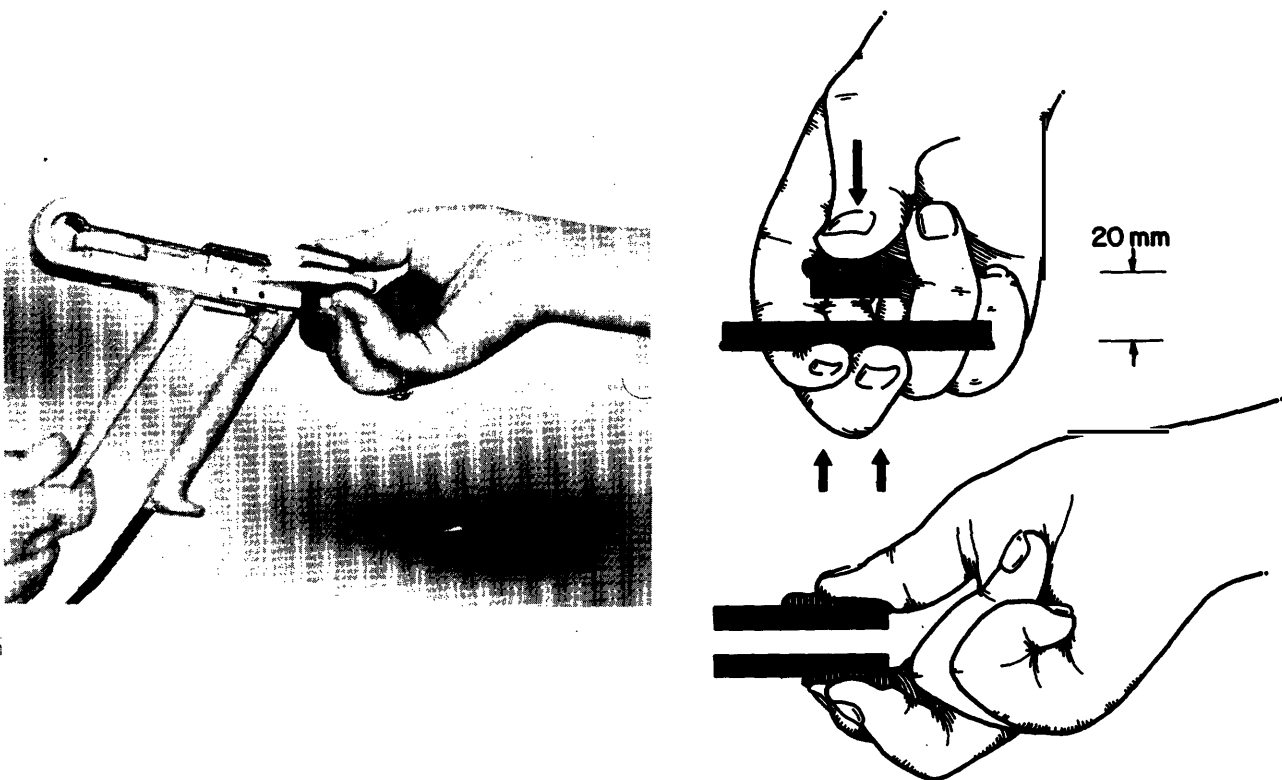

GRIP - 3 POINT PINCH (KP)

COMBINED SEXES

AGE	N	MEAN	ST. DEV	MIN	10%	MEDIAN	90%	MAX
3	7	1.6	0.5	1.1	1.1	1.7	2.4	2.4
4	35	2.1	0.7	1.0	1.3	2.1	2.9	3.6
5	31	2.3	0.5	1.1	1.6	2.3	2.9	3.6
6	41	2.9	0.7	1.5	2.3	2.8	3.7	4.8
7	31	3.4	0.7	2.1	2.7	3.4	4.1	5.8
8	31	3.8	0.7	2.2	3.0	3.9	4.7	5.2
9	32	4.3	1.1	2.3	3.0	4.2	5.4	6.9
10	15	4.1	0.8	2.6	3.0	4.5	4.8	4.9

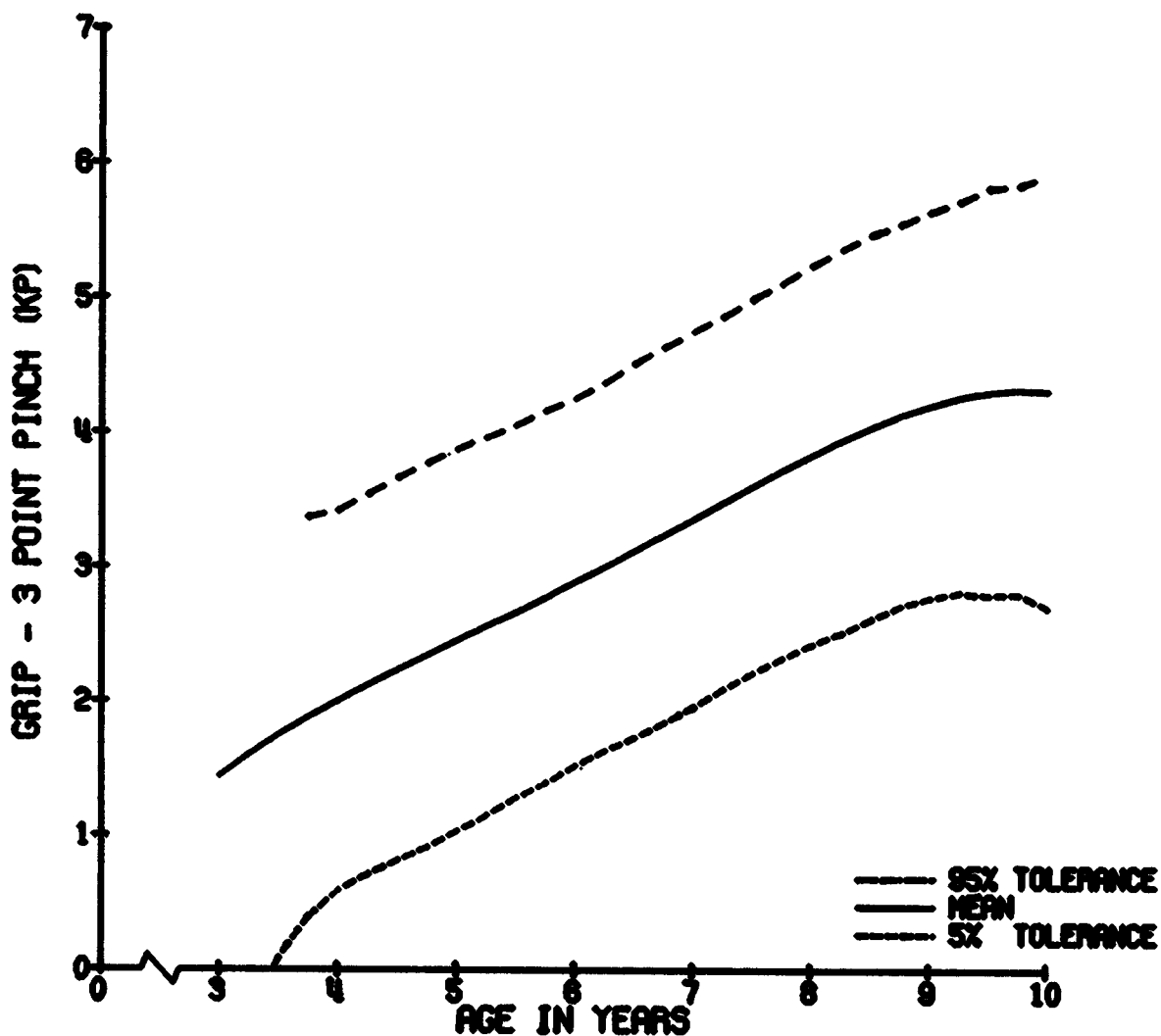

GRIP - 3 POINT PINCH (KP)

MALES

AGE	N	MEAN	ST. DEV	MIN	10%	MEDIAN	90%	MAX
3	5	1.7	0.5	1.2	1.2	1.7	2.4	2.4
4	17	2.3	0.7	1.0	1.2	2.4	2.9	3.6
5	10	2.3	0.7	1.1	1.1	2.3	3.1	3.6
6	26	2.9	0.6	1.5	2.2	2.8	3.7	4.5
7	14	3.5	0.6	2.7	2.8	3.4	4.2	4.9
8	19	4.0	0.7	2.6	3.2	4.1	5.1	5.2
9	13	5.0	1.1	3.0	3.8	4.9	6.5	6.9
10	7	4.4	0.5	3.6	3.6	4.6	4.9	4.9

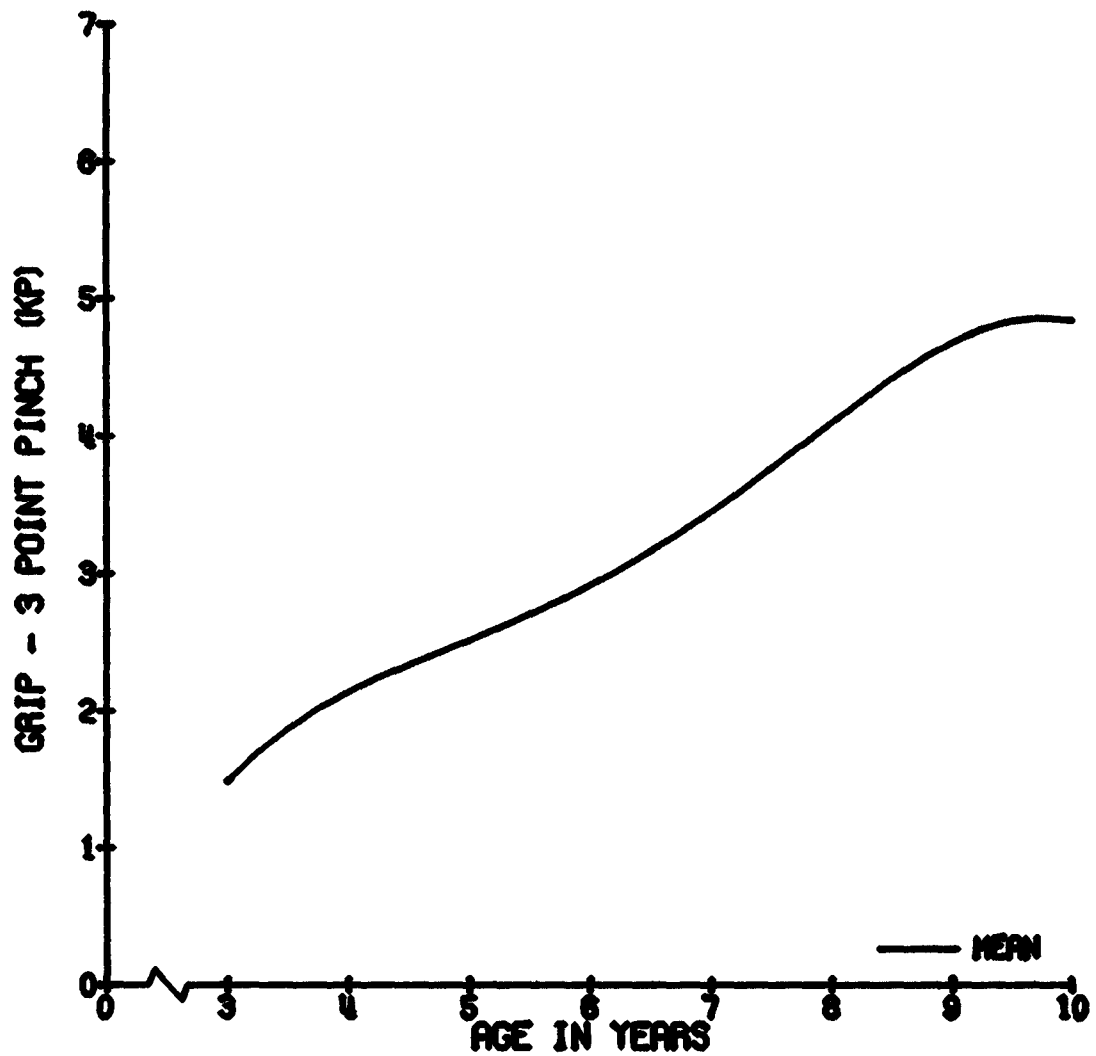

GRIP - 3 POINT PINCH (KG)

FEMALES

AGE	N	MEAN	ST. DEV	MIN	10%	MEDIAN	90%	MAX
3	2	1.4	0.5	1.1	1.1	1.4	1.8	1.8
4	18	1.9	0.6	1.2	1.4	1.7	2.8	3.6
5	21	2.2	0.5	1.5	1.6	2.3	2.7	3.2
6	15	3.0	0.8	2.2	2.3	2.8	4.5	4.8
7	17	3.2	0.8	2.1	2.4	3.1	3.6	5.8
8	12	3.5	0.7	2.2	2.8	3.6	4.2	4.7
9	19	3.8	0.8	2.3	2.9	3.7	5.0	5.2
10	8	3.8	0.9	2.6	2.6	3.9	4.7	4.7

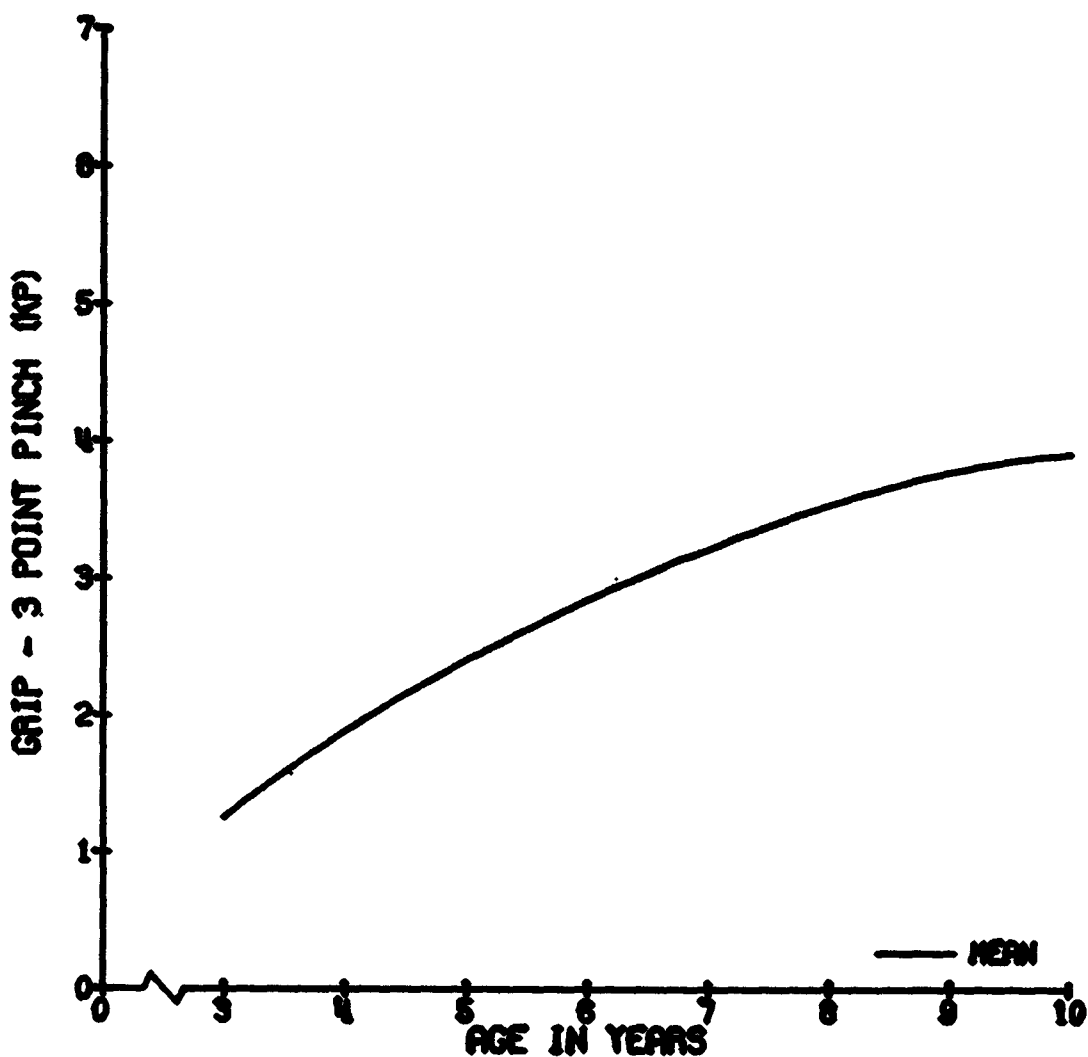

GRIP: FIVE-POINT PINCH

DESCRIPTION OF TEST: The anterior surface of all four finger tips (distal end of phalanges #2-#5) are pressed in opposition to the anterior surface of the thumb tip (distal end of phalanx #1).

TEST POSITION: Thumb and four fingers are flexed in a plane parallel to the saggital plane so that the thumb tip is opposite the second and third finger tips. The anterior surface of the thumb tip clears the anterior surfaces of the four finger tips by 20 mm (see below).

ANTHROPOMETRIC MEASUREMENTS: None

ADJUSTMENT OF EQUIPMENT: The finger plates of the grip transducers are set 20 mm apart.

INSTRUCTIONS TO SUBJECT: The child brings the tips of the fingers together and pinches the two plates using his thumb and four fingers.

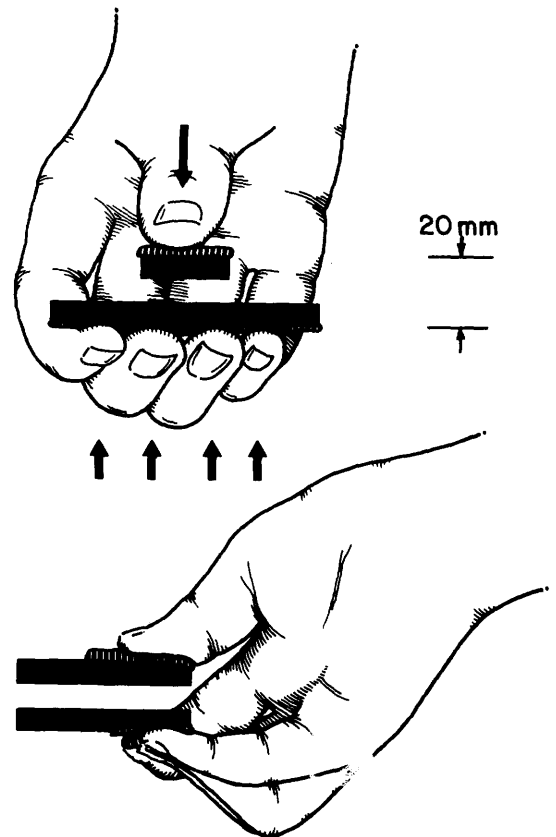
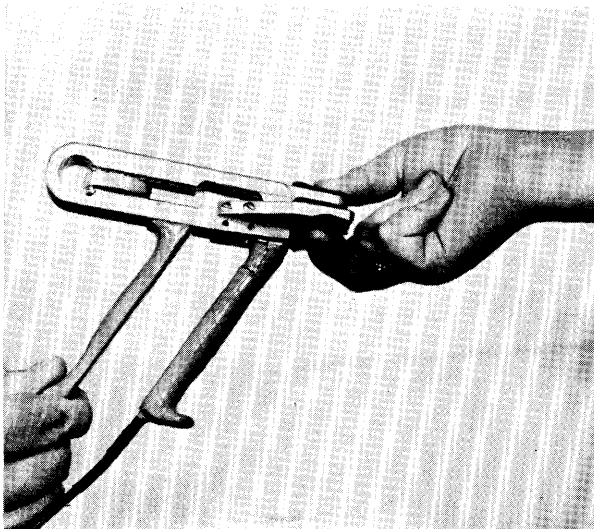

GRIP - 5 POINT PINCH (KP)

COMBINED SEXES

AGE	N	MEAN	ST. DEV	MIN	10%	MEDIAN	90%	MAX
3	7	1.9	0.4	1.4	1.4	2.0	2.3	2.3
4	36	2.4	0.6	1.1	1.7	2.5	3.2	3.7
5	31	2.7	0.5	1.6	2.2	2.6	3.4	4.3
6	41	3.2	0.8	2.2	2.5	3.0	4.4	5.8
7	31	3.7	0.8	2.4	2.8	3.6	4.7	6.3
8	31	4.3	1.2	2.2	2.9	4.1	5.9	7.8
9	32	4.7	1.3	3.0	3.4	4.3	6.7	8.0
10	15	4.5	0.9	2.8	3.5	4.6	5.6	5.8

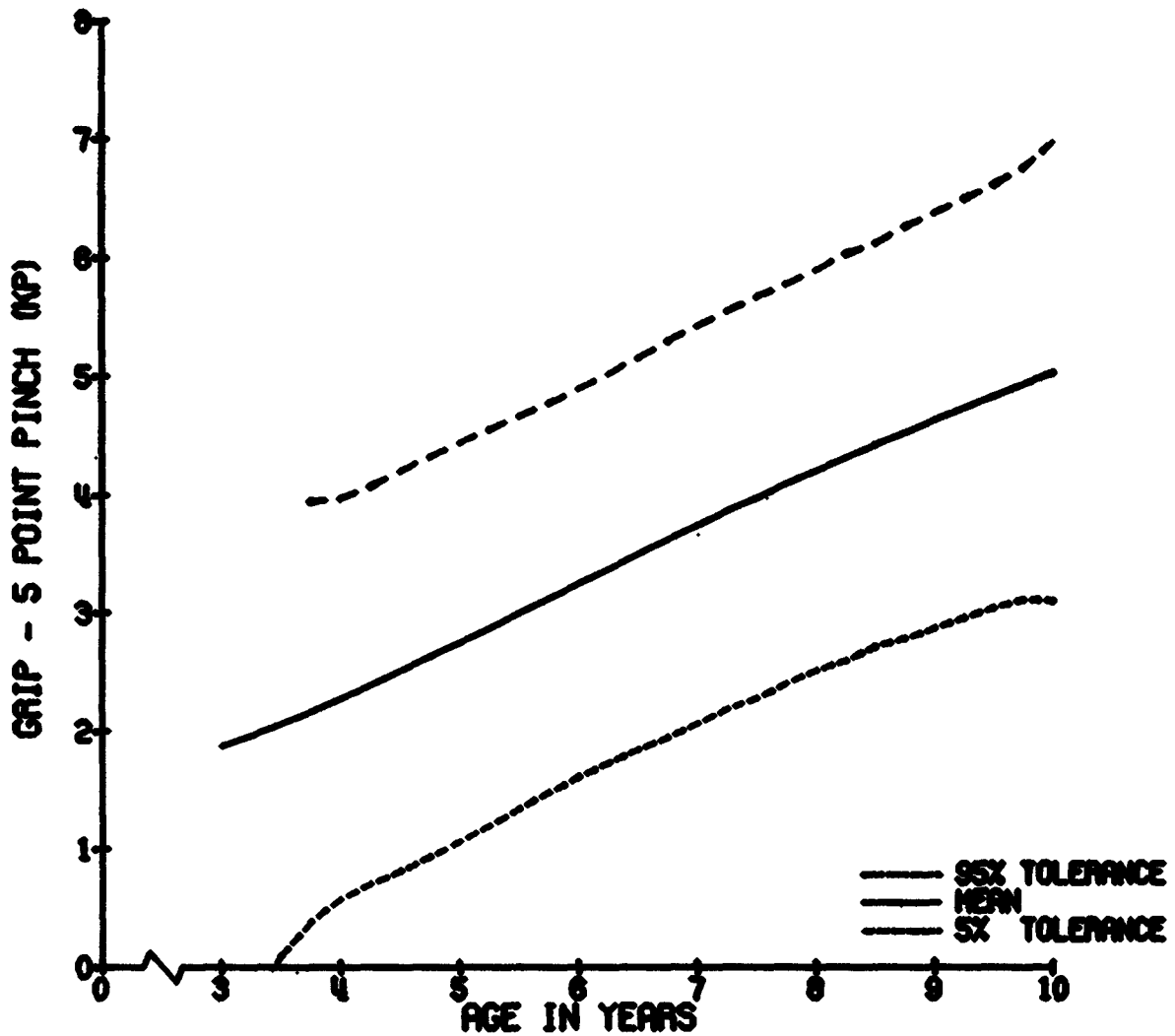

GRIP - 5 POINT PINCH (KP)

MALES

AGE	N	MEAN	ST. DEV	MIN	10%	MEDIAN	90%	MAX
3	5	1.9	0.4	1.4	1.4	2.0	2.3	2.3
4	18	2.5	0.5	1.1	1.7	2.6	3.2	3.3
5	10	2.8	0.7	2.2	2.2	2.6	3.9	4.3
6	26	3.3	0.8	2.2	2.4	3.2	4.4	5.8
7	14	3.7	0.7	2.8	2.8	3.7	4.7	5.3
8	19	4.6	1.3	2.7	2.9	4.4	6.5	7.8
9	13	5.5	1.4	3.8	3.9	5.3	7.0	8.0
10	7	4.9	0.6	3.9	3.9	4.9	5.6	5.6

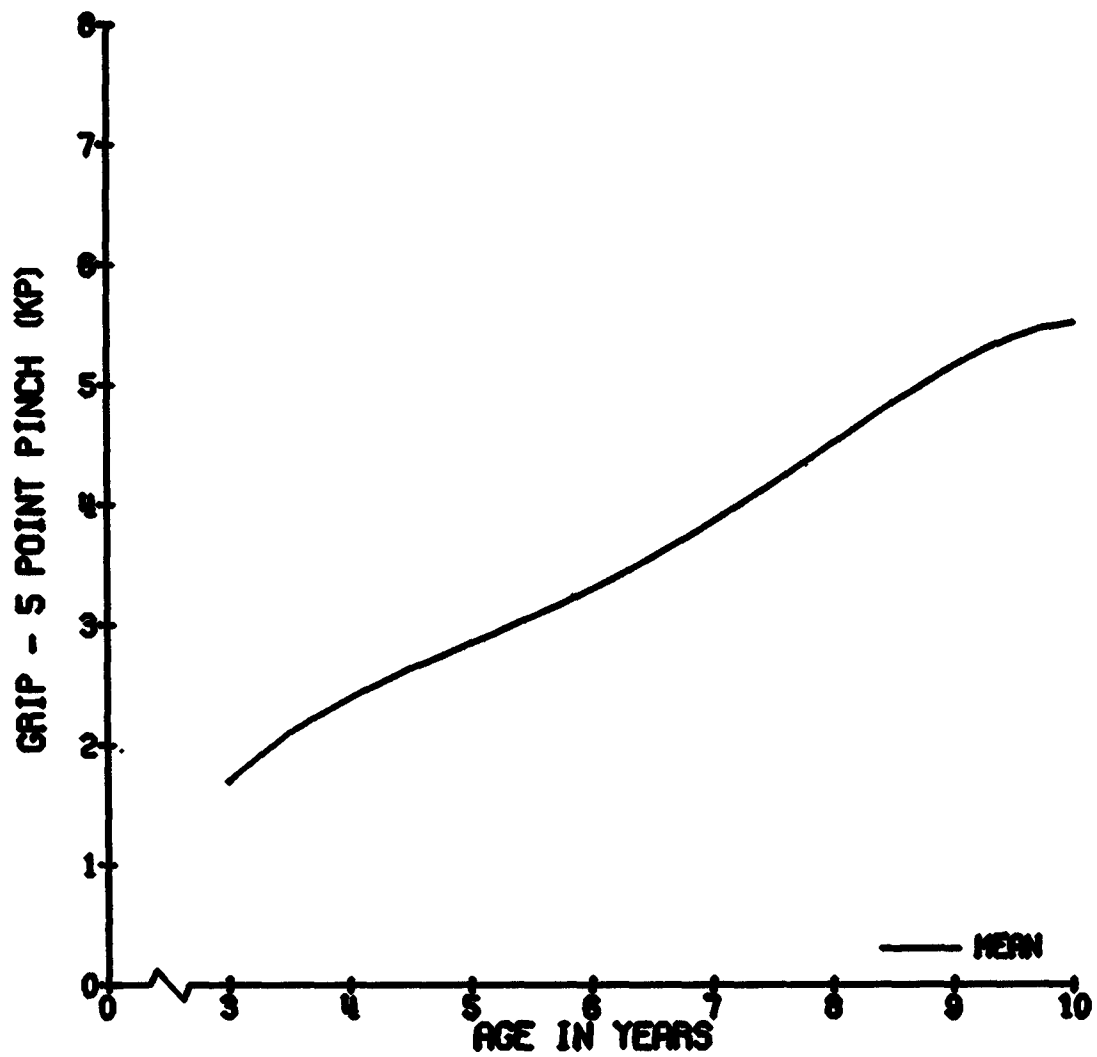

GRIP - 5 POINT PINCH (KP)

FEMALES

AGE	N	MEAN	ST. DEV	MIN	10%	MEDIAN	90%	MAX
3	2	1.3	0.4	1.5	1.5	1.8	2.0	2.0
4	18	2.2	0.6	1.6	1.6	2.0	3.2	3.7
5	21	2.6	0.5	1.6	2.1	2.6	3.1	3.5
6	15	3.1	0.7	2.2	2.5	3.0	4.4	5.1
7	17	3.6	0.9	2.4	2.6	3.5	4.7	6.3
8	12	3.9	0.9	2.2	2.8	4.0	4.5	5.9
9	19	4.2	0.9	3.0	3.1	4.0	5.5	5.9
10	8	4.2	1.0	2.8	2.8	4.2	5.8	5.8

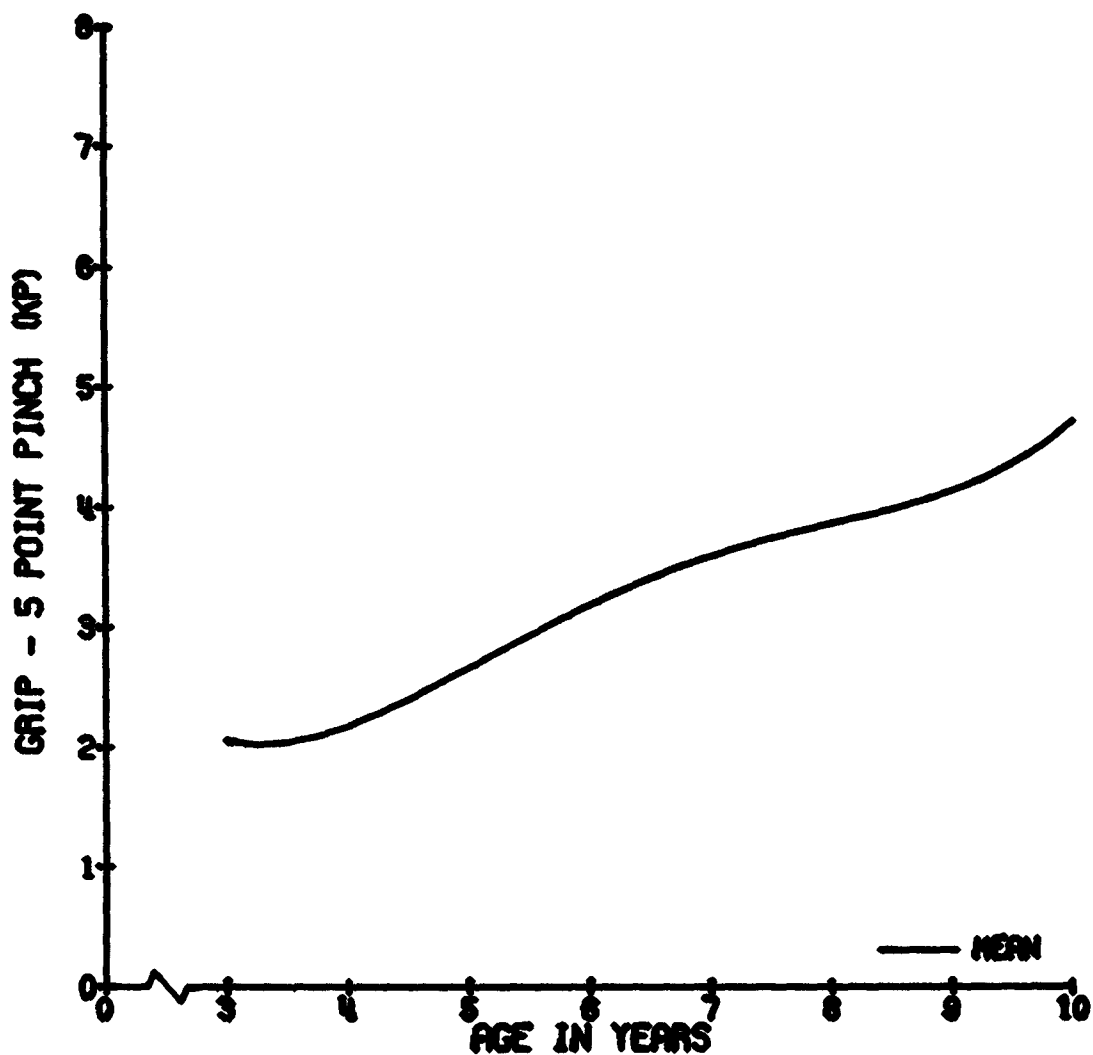

GRIP: LATERAL PINCH

DESCRIPTION OF TEST: The lateral surface of the second knuckle (proximal interphalangeal joint) of the first finger (phalanx #2) is pressed in opposition to the anterior surface of the thumb tip (distal end of phalanx #1).

TEST POSITION: The four fingers are flexed in a plane parallel to the saggital plane into a tight fist. The thumb tip is flexed toward the second knuckle of the first finger to a clearance of 20 mm (see below).

ANTHROPOMETRIC MEASUREMENT: None

ADJUSTMENT OF EQUIPMENT: The finger plates of the grip transducer are set 20 mm apart.

INSTRUCTIONS TO SUBJECT: The child makes a fist and pinches the two plates together using his thumb and side of first finger.

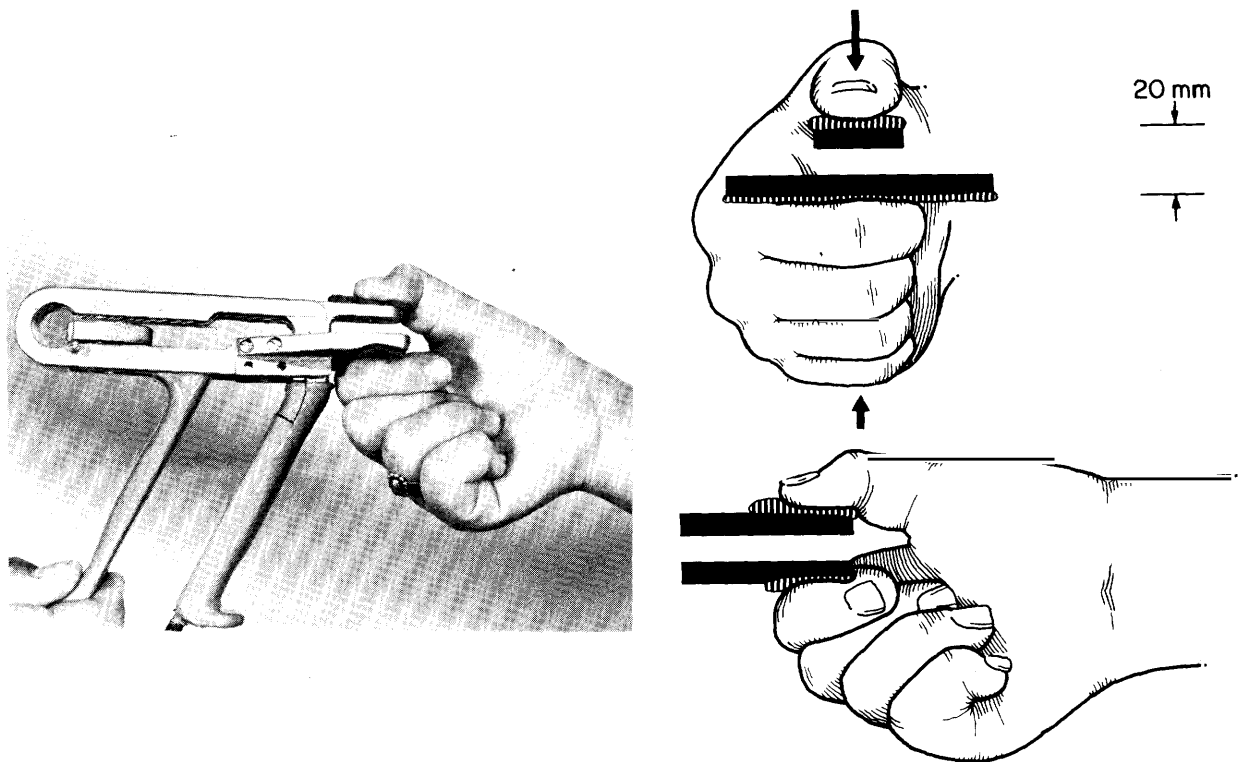

GRIP - LATERAL (KP)

COMBINED SEXES

AGE	N	MEAN	ST. DEV	MIN	10%	MEDIAN	90%	MAX
3	9	1.9	0.5	1.3	1.3	1.9	3.0	3.0
4	37	2.7	0.6	1.6	2.0	2.7	3.5	3.9
5	30	3.2	0.8	1.8	2.3	3.1	4.0	5.4
6	42	3.9	0.6	2.7	3.1	3.9	4.6	5.2
7	31	4.2	0.7	3.1	3.4	4.1	4.8	6.5
8	31	4.8	1.0	2.8	3.6	5.0	6.3	6.8
9	32	5.3	1.0	3.4	3.9	5.1	6.4	7.2
10	15	5.2	0.9	3.4	4.0	5.4	6.3	6.7

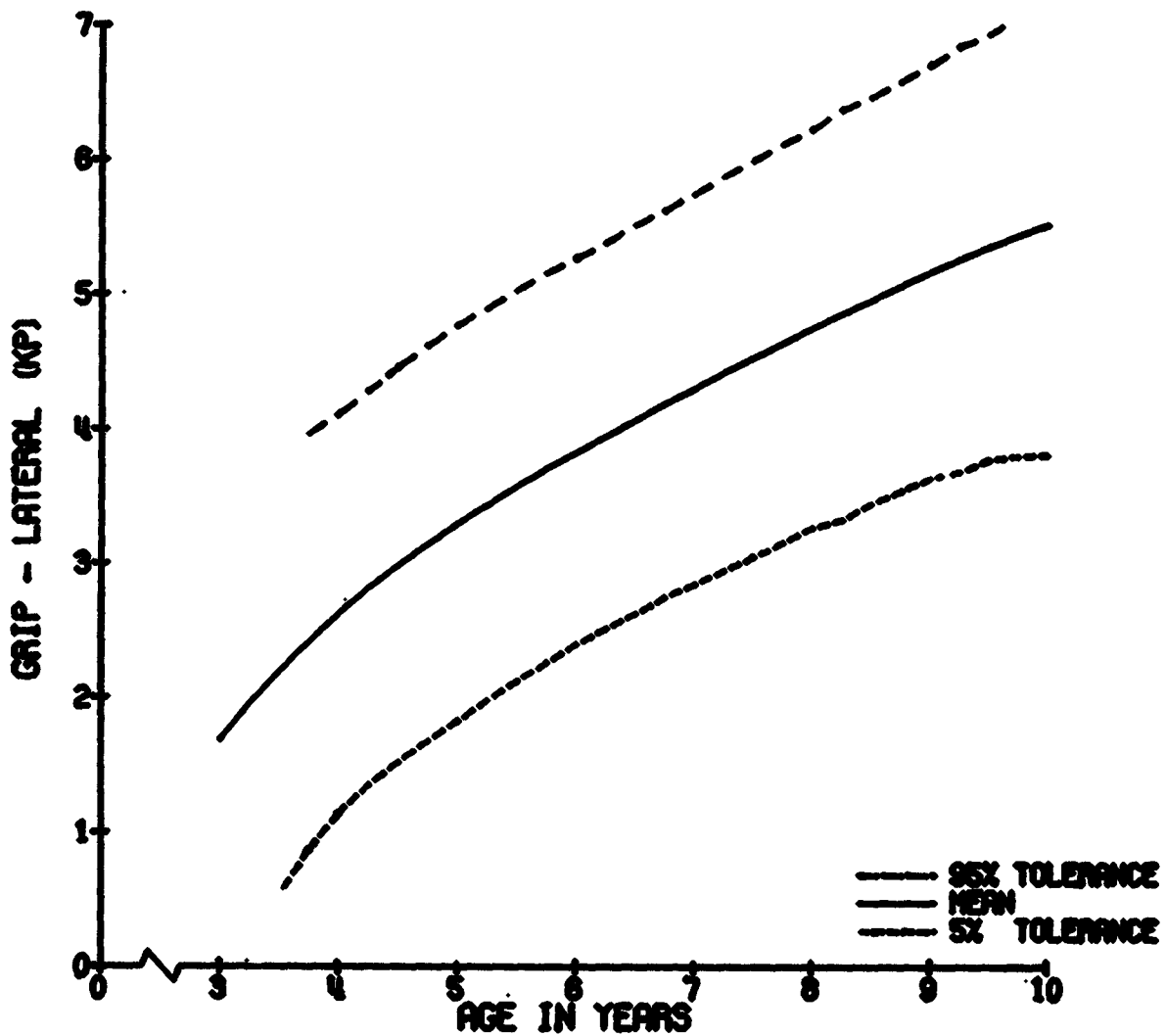

GRIP - LATERAL (KP)

MALES

AGE	N	MEAN	ST. DEV	MIN	10%	MEDIAN	90%	MAX
3	7	2.0	0.6	1.3	1.3	1.9	3.0	3.0
4	19	2.9	0.5	1.7	2.2	2.9	3.5	3.9
5	9	3.4	1.3	1.8	1.8	2.7	5.4	5.4
6	26	4.0	0.6	3.0	3.1	3.9	4.9	5.2
7	14	4.4	0.9	3.2	3.4	4.3	5.7	6.5
8	19	5.1	0.9	3.6	3.7	5.0	6.4	6.8
9	13	5.9	0.9	3.9	5.1	5.7	6.9	7.2
10	7	5.4	0.8	4.4	4.4	5.6	6.3	6.3

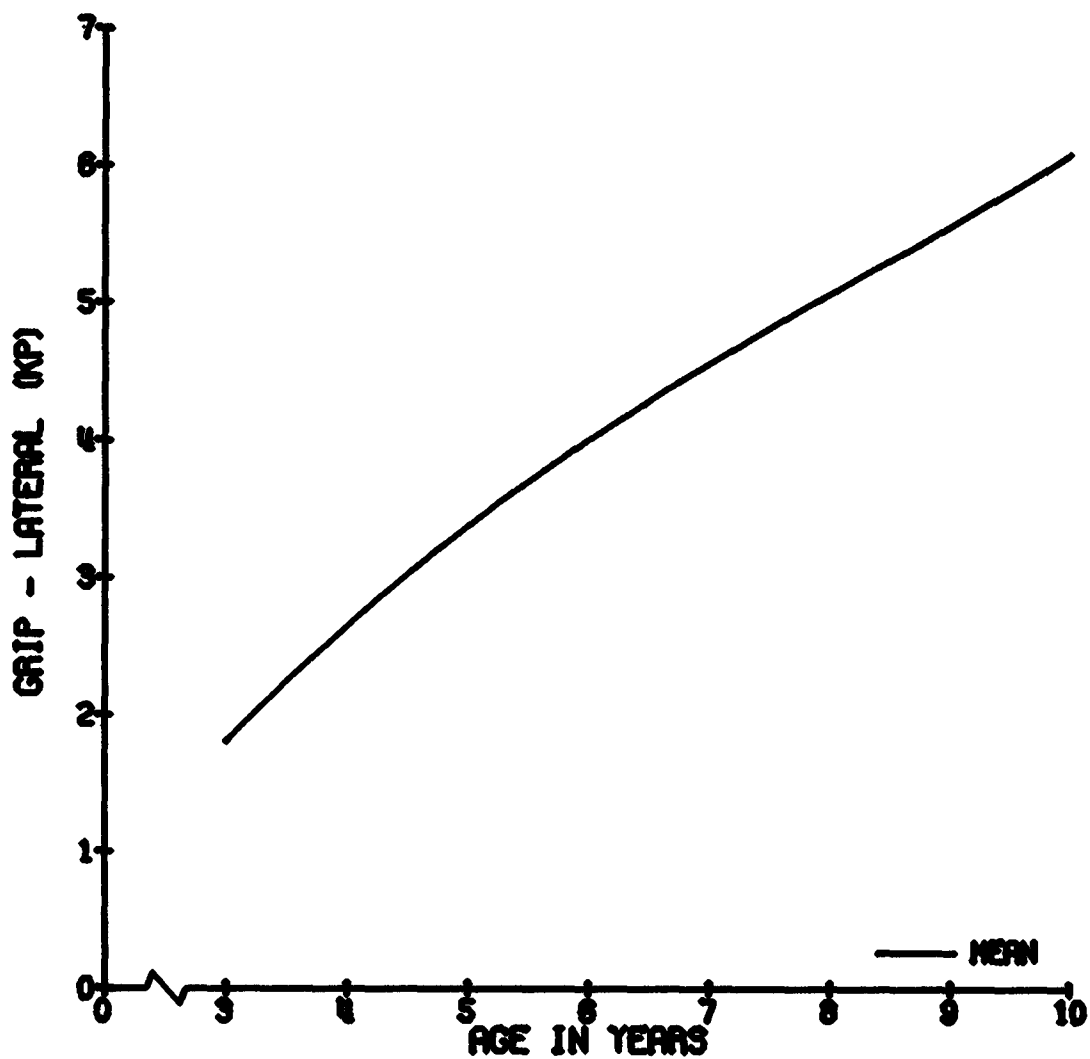

GRIP - LATERAL (KP)

FEMALES

AGE	N	MEAN	ST. DEV	MIN	10%	MEDIAN	90%	MAX
3	2	1.7	0.2	1.6	1.6	1.7	1.9	1.9
4	18	2.6	0.6	1.6	1.9	2.5	3.8	3.9
5	21	3.1	0.4	2.1	2.8	3.1	3.6	4.0
6	16	3.7	0.5	2.7	2.9	3.8	4.2	4.4
7	17	3.9	0.5	3.1	3.1	3.9	4.7	4.7
8	12	4.3	0.9	2.8	3.4	4.6	5.2	5.3
9	19	4.9	0.9	3.4	3.4	4.9	6.3	6.4
10	8	5.0	1.1	3.4	3.4	5.1	6.7	6.7

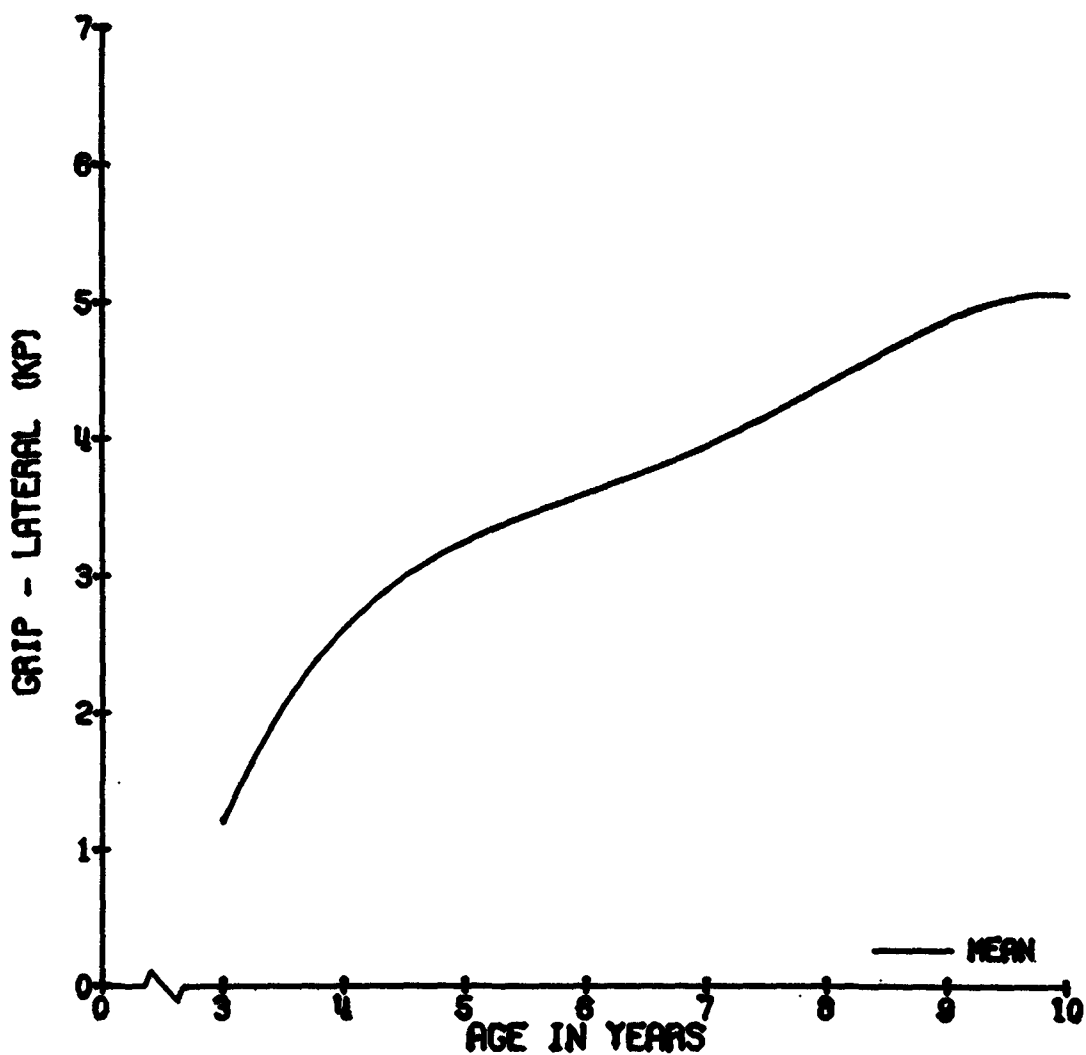

GRIP: SQUEEZE

DESCRIPTION OF TEST: The anterior surfaces of the second knuckles (proximal interphalangeal joints) of all four fingers (phalanges #2-#5) are pressed in opposition to the second knuckle of the thumb phalanx #1).

TEST POSITION: The four fingers are flexed toward the thumb in a plane parallel to the sagittal plane. The thumb is flexed toward the second finger (phalange #3) in the same plane. The thumb tip (distal end) clears the second finger tip by no more than 5 mm.

ANTHROPOMETRIC MEASUREMENTS: The length of the third phalanx is measured with an anthropometer.

ADJUSTMENT OF EQUIPMENT: The handle span of the grip transducer is set to one-fourth of the third phalangeal length as indicated in the diagram below.

INSTRUCTIONS TO SUBJECT: The child squeezes the handle of the grip fixture together with his entire hand.

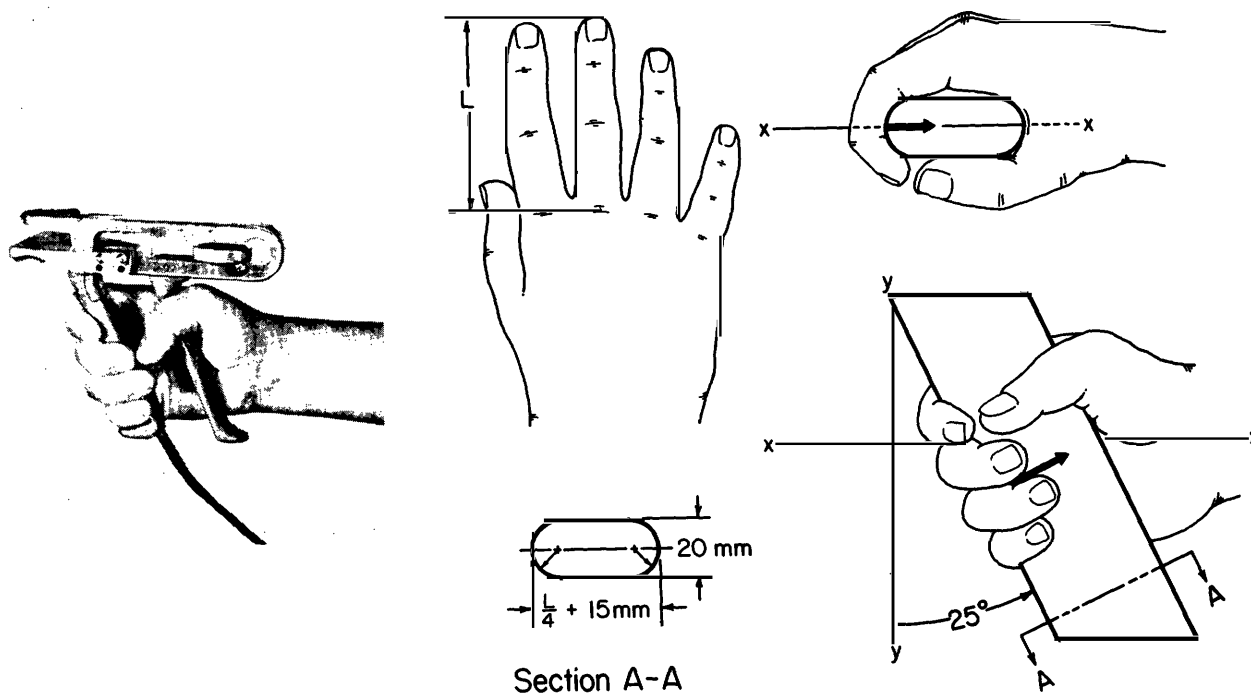

GRIP - SQUEEZE (KP)

COMBINED SEXES

AGE	N	MEAN	ST. DEV	MIN	10%	MEDIAN	90%	MAX
3	12	4.6	1.5	3.1	3.2	4.3	6.8	8.0
4	61	5.9	1.8	2.9	3.7	5.6	8.3	11.6
5	63	7.3	1.9	3.8	5.1	7.2	10.1	12.1
6	57	9.1	2.3	3.5	5.7	9.4	11.4	13.8
7	78	10.7	3.3	3.5	6.2	11.0	14.8	17.9
8	71	12.7	3.4	6.6	8.1	12.5	17.8	21.3
9	81	14.8	3.6	5.7	10.3	14.9	18.7	23.6
10	28	16.7	3.8	9.6	12.9	16.7	22.0	26.2

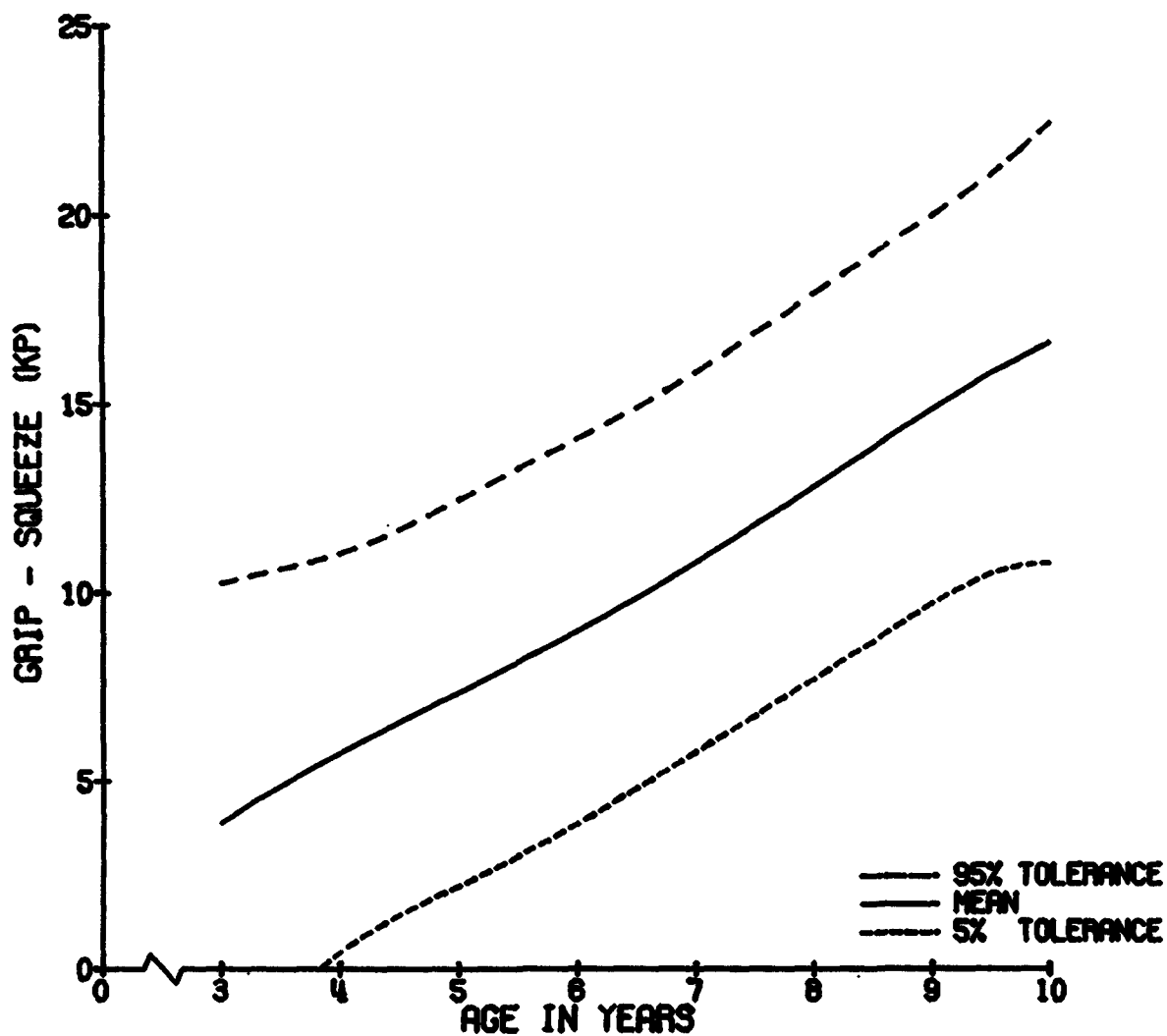

GRIP - SQUEEZE (KP)

MALES

AGE	N	MEAN	ST. DEV	MIN	10%	MEDIAN	90%	MAX
3	8	5.2	1.6	3.2	3.2	4.6	8.0	8.0
4	27	6.3	1.5	3.3	3.9	6.3	8.4	8.7
5	24	7.3	2.1	3.8	5.2	7.0	10.9	12.1
6	32	9.6	2.1	4.4	6.9	10.0	11.4	13.8
7	35	11.2	3.7	4.3	5.5	12.1	15.5	17.9
8	37	13.1	3.3	7.3	8.4	13.0	18.3	21.3
9	38	16.0	3.6	8.4	11.2	16.0	20.7	23.6
10	16	18.3	3.6	13.8	13.9	17.6	22.8	26.2

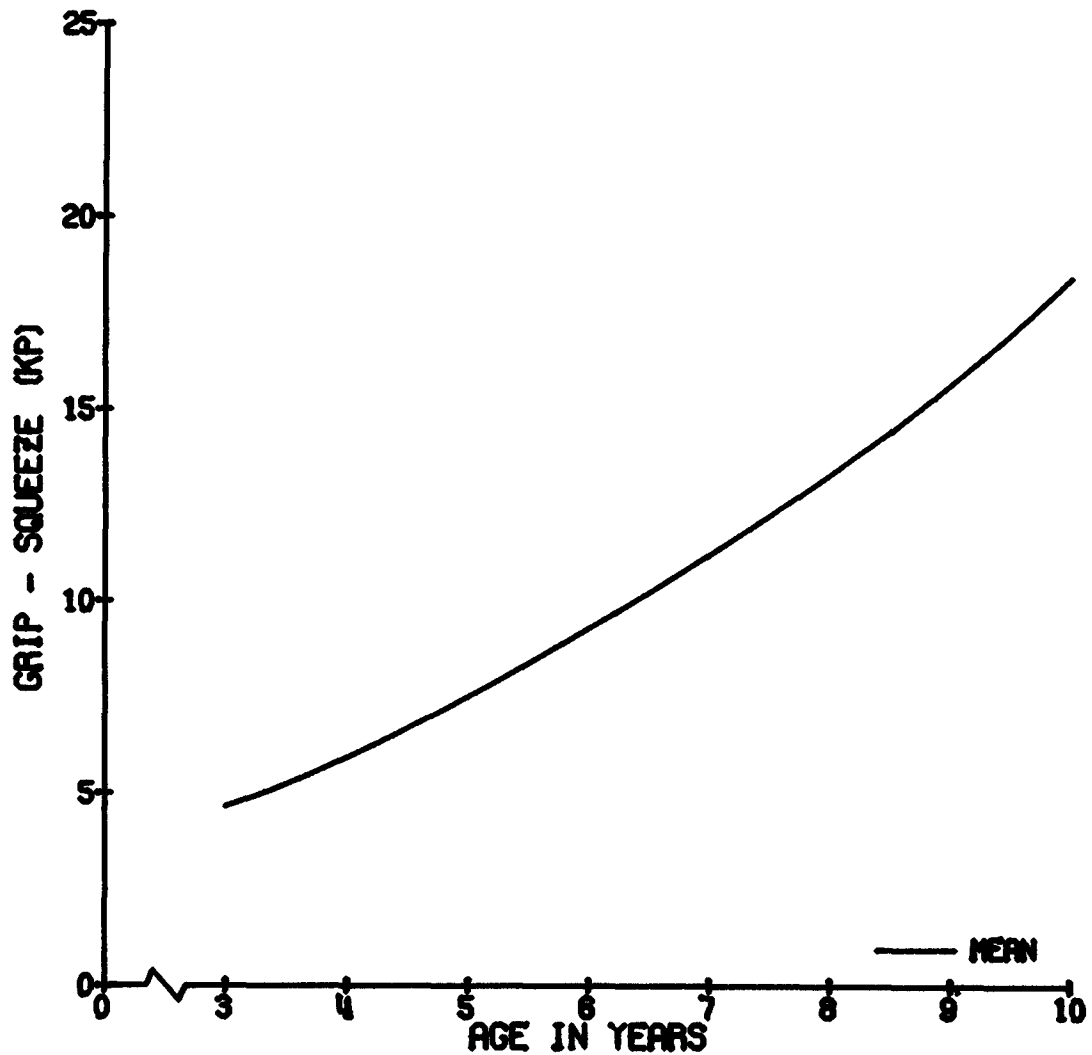

GRIP - SQUEEZE (KP)

FEMALES

AGE	N	MEAN	ST. DEV	MIN	10%	MEDIAN	90%	MAX
3	4	3.6	0.5	3.1	3.1	3.6	4.1	4.1
4	34	5.5	1.9	2.9	3.3	5.2	7.5	11.6
5	39	7.3	1.8	3.8	5.0	7.5	9.4	11.4
6	25	8.4	2.3	3.5	5.7	8.6	11.2	13.0
7	43	10.3	2.8	3.5	7.0	10.9	13.2	16.5
8	34	12.2	3.5	6.6	7.8	11.7	17.8	19.7
9	43	13.7	3.2	5.7	9.7	13.6	18.1	19.8
10	12	14.6	2.8	9.6	11.0	13.9	18.1	19.3

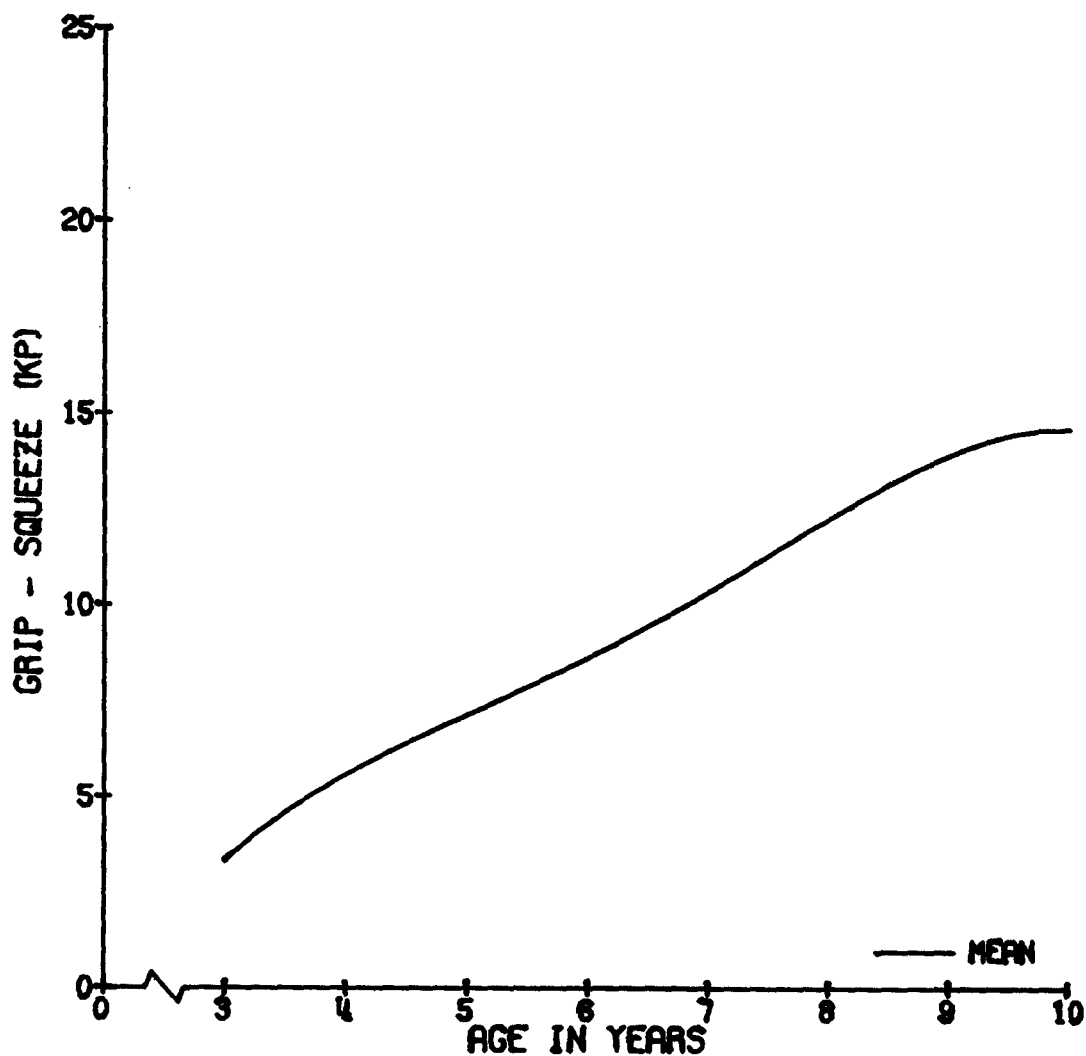

3.3. Linkage Measurements

3.3.1. Interpretation of Linkage Measurements

The size and relative proportions of the arm, forearm, thigh, leg, trunk, and head vary considerably in individuals, and these proportions change during the process of growth. The bones are rigid members which specify the length of a body segment. In order to do biomechanical modeling and to give a reasonable translation between torque and force for a single individual, one needs information about the size of body linkages.

Ideally, body linkages should be measured from the center of one joint to the center of the joint at the opposite end of the link. Physical anthropologists and anatomists agree on the difficulty of making precise linkage measurements. This is true primarily because of the difficulty in finding external landmarks which exactly correlate with the joint centers of rotation for several body joints. The shoulder is an example of a joint for which it is extremely difficult to define the precise location of the joint center of rotation. The knee does not possess a single joint center of rotation, but executes translatory motion as the joint is flexed and extended, and thus, has no single center of rotation. Likewise, the center of rotation of the hip joint is extremely difficult to define and to correlate with precise external landmarks.

In spite of the difficulty of defining the joint center of rotation, it is nonetheless possible to make approximate measurement of the linkage lengths. It is possible to arrive intuitively at an approximate joint center for motion over a limited range. The joint center may be estimated by moving the extremity through a small range of motion and observing the point at which the least amount of motion occurs. For purposes of this study, we obtained linkage measurements with a child seated in the position that he would occupy for strength measurements. Linkage measurements were then made from one joint center to the joint center at the opposite end of the link.

A preliminary investigation of inter- and intra-observer variability was completed. With respect to inter-observer variability, 3 observers made measurements on each of 12 anatomical sites. For each site the intraclass correlation, R , was computed. R is interpretable as a measure of correlation among the observers. The closer R is to one, the more homogeneous are the observers. For the 3 observers compared, R ranged from 0.47 to 0.97 for the 12 sites. All R 's were significantly greater than zero ($P < 0.005$). The poorest correlations were 0.47, 0.58, and 0.66 for sacral, carpal, and clavicle, respectively. The remaining 9 sites measured had R 's in excess of 0.77. Thus the overall consistency among the observers was felt to be quite good.

For intra-observer variability assessment, each of the three observers measured 5 subjects twice for the same 12 anatomical sites. The coefficient of variation (C.V.) [i.e., the standard deviation divided by the mean, where the standard deviation was found by taking the square root of the pooled within observer by subject variances] was computed for each site measured. These C.V.'s ranged from 1.53% to 5.91%. The smallest C.V. was for tibial while the largest was for sacral. The mean of these C.V.'s was 3.57%. For each site the standard deviation was less than the subject-to-subject standard deviation. Thus, it is believed that intraobserver variability is within acceptable limits. (See Figure 24)

	<u>Interobserver</u>		<u>Intraobserver</u>		
	<u>R</u>	<u>P</u>	<u>M</u>	<u>S.D.</u>	<u>C.V. (%)</u>
Finger	0.92	P<0.001	7.87	.23	2.92
Carpal	0.58	P<0.001	5.75	.33	5.74
Radial	0.91	"	17.90	.37	2.07
Humerus	0.93	"	18.27	.61	3.34
Sacral	0.47	P<0.005	8.80	.52	5.91
Lumbar	0.87	P<0.001	22.93	.98	4.27
Cervical	0.77	"	13.78	.60	4.35
Femoral	0.97	"	30.60	.66	2.16
Tibial	0.97	"	29.45	.45	1.53
Tarsal	0.80	"	13.25	.40	3.02
Clavicle	0.66	"	19.15	.88	4.60
Pelvic	0.84	"	16.52	.49	2.97

Figure 24 Reproducibility of Linkage Measurements

The following section describes the measurement and includes both photograph and sketch to illustrate the anatomic position in which the measurement was made and how the measurement was taken. Only right extremities were measured. The data tables and graphs are subjected to the same interpretations as those of the strength data in Section 3.2.1.

3.3.2. Index of Linkage Measurements

<u>Measurement</u>	<u>Page</u>
1. Third Phalanx	213
2. Carpal	215
3. Radial	217
4. Humeral	219
5. Sacral	221
6. Thoracolumbar	223
7. Cervical	225
8. Femoral	227
9. Tibial	229
10. Tarsal	231
11. Clavicle	233
12. Pelvic	235
13. Standing Height	237
14. Weight	239

THIRD PHALANX

DESCRIPTION: Measure from the third knuckle (third carpophalangeal joint center) to the finger tip (distal end of the third phalanx).

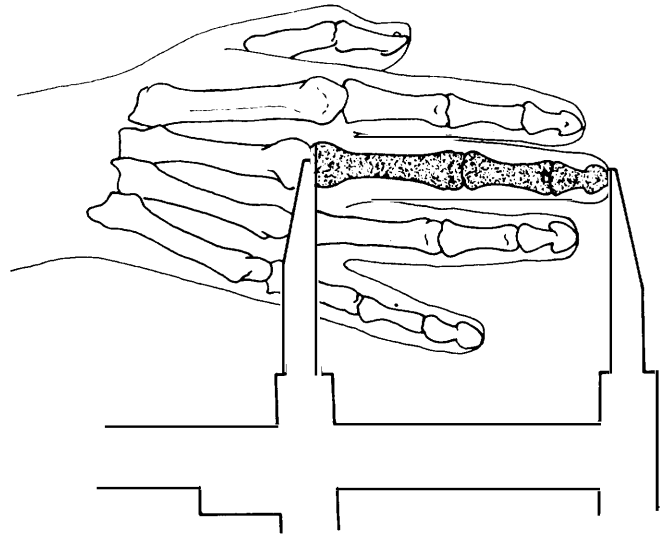
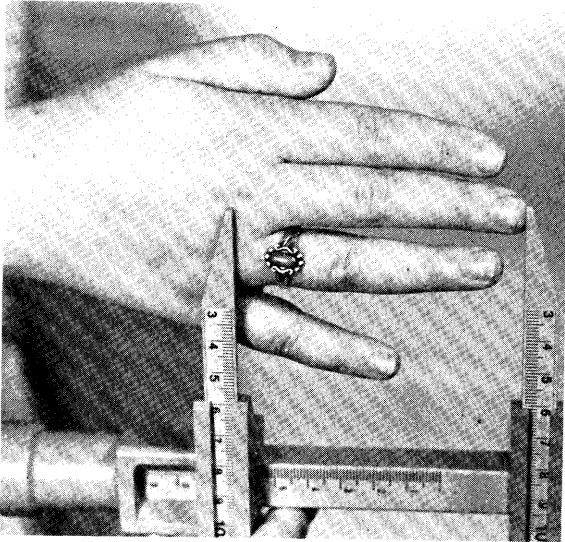

THIRD PHALANX (CM)

COMBINED SEXES

AGE	N	MEAN	ST. DEV	MIN	10%	MEDIAN	90%	MAX
3	12	6.4	0.5	5.5	6.0	6.5	7.0	7.0
4	75	6.6	0.5	5.5	6.0	6.5	7.0	7.5
5	82	6.9	0.5	6.0	6.5	7.0	7.5	8.0
6	70	7.3	0.5	6.5	6.5	7.0	8.0	9.0
7	79	7.7	0.5	6.5	7.0	7.5	8.5	9.0
8	71	8.0	0.6	7.0	7.5	8.0	9.0	9.5
9	81	8.3	0.5	7.0	8.0	8.0	9.0	9.5
10	28	8.5	0.5	7.5	8.0	8.5	9.0	9.5

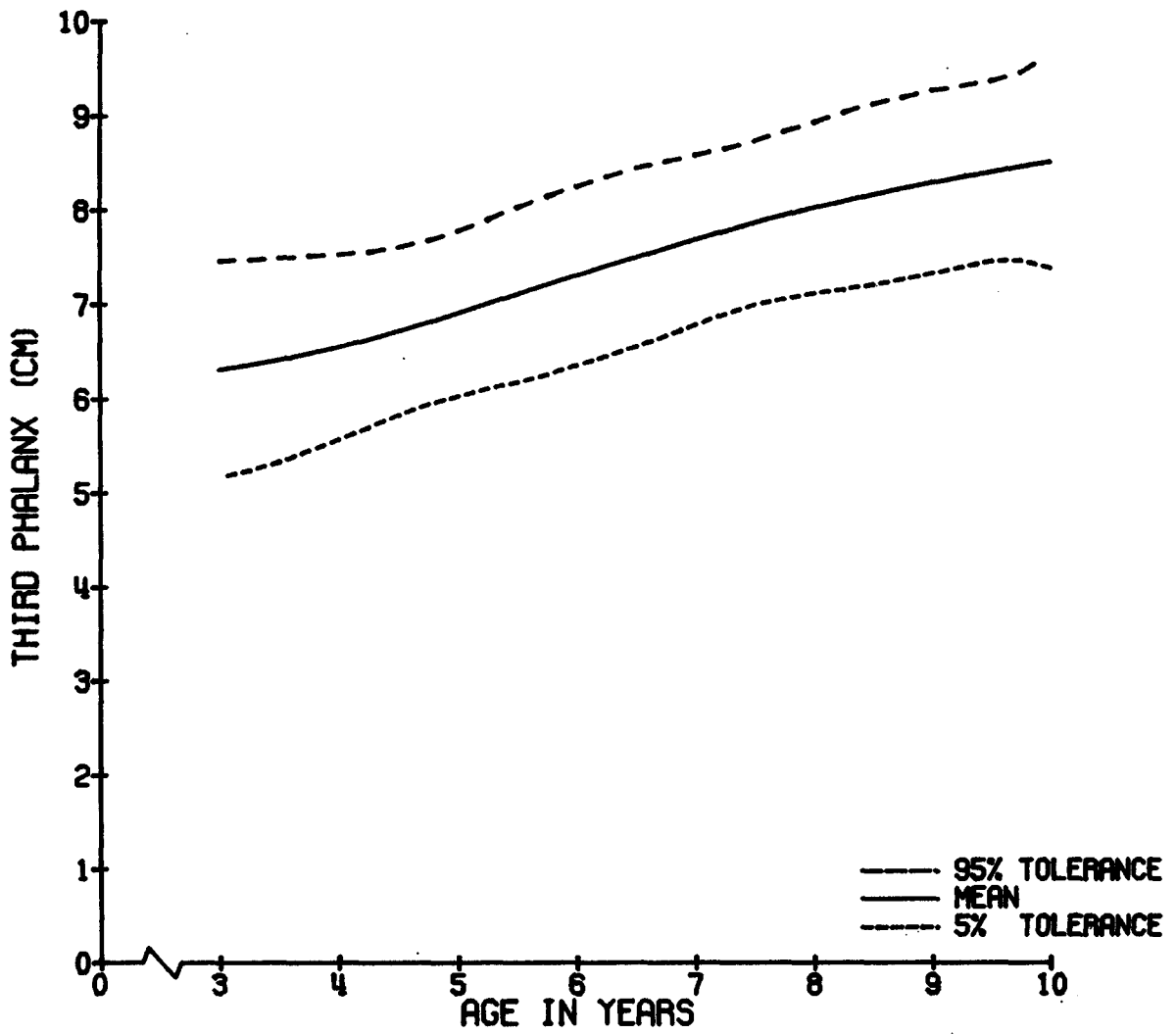

CARPAL LINKAGE

DESCRIPTION: Measure from the wrist (radiocarpal joint center) to the third knuckle (third carpophalangeal joint center).

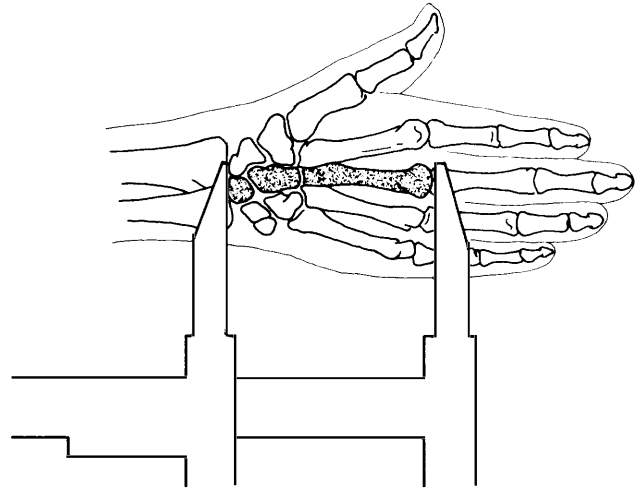
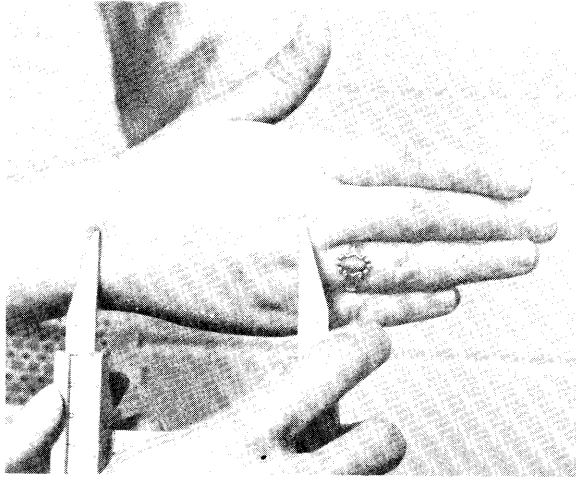

CARPAL (CM)

COMBINED SEXES

AGE	N	MEAN	ST. DEV	MIN	10%	MEDIAN	90%	MAX
3	12	4.4	0.6	3.5	3.5	4.5	5.0	5.5
4	75	4.7	0.6	3.5	4.0	4.5	5.5	6.5
5	82	5.1	0.6	4.0	4.5	5.0	6.0	6.5
6	70	5.1	0.6	4.0	4.5	5.0	6.0	7.0
7	79	5.5	0.6	4.0	5.0	5.5	6.5	7.0
8	71	5.9	0.7	4.5	5.0	6.0	7.0	8.0
9	81	6.0	0.6	4.5	5.0	6.0	6.5	8.0
10	28	6.1	0.7	4.5	5.5	6.0	7.0	7.5

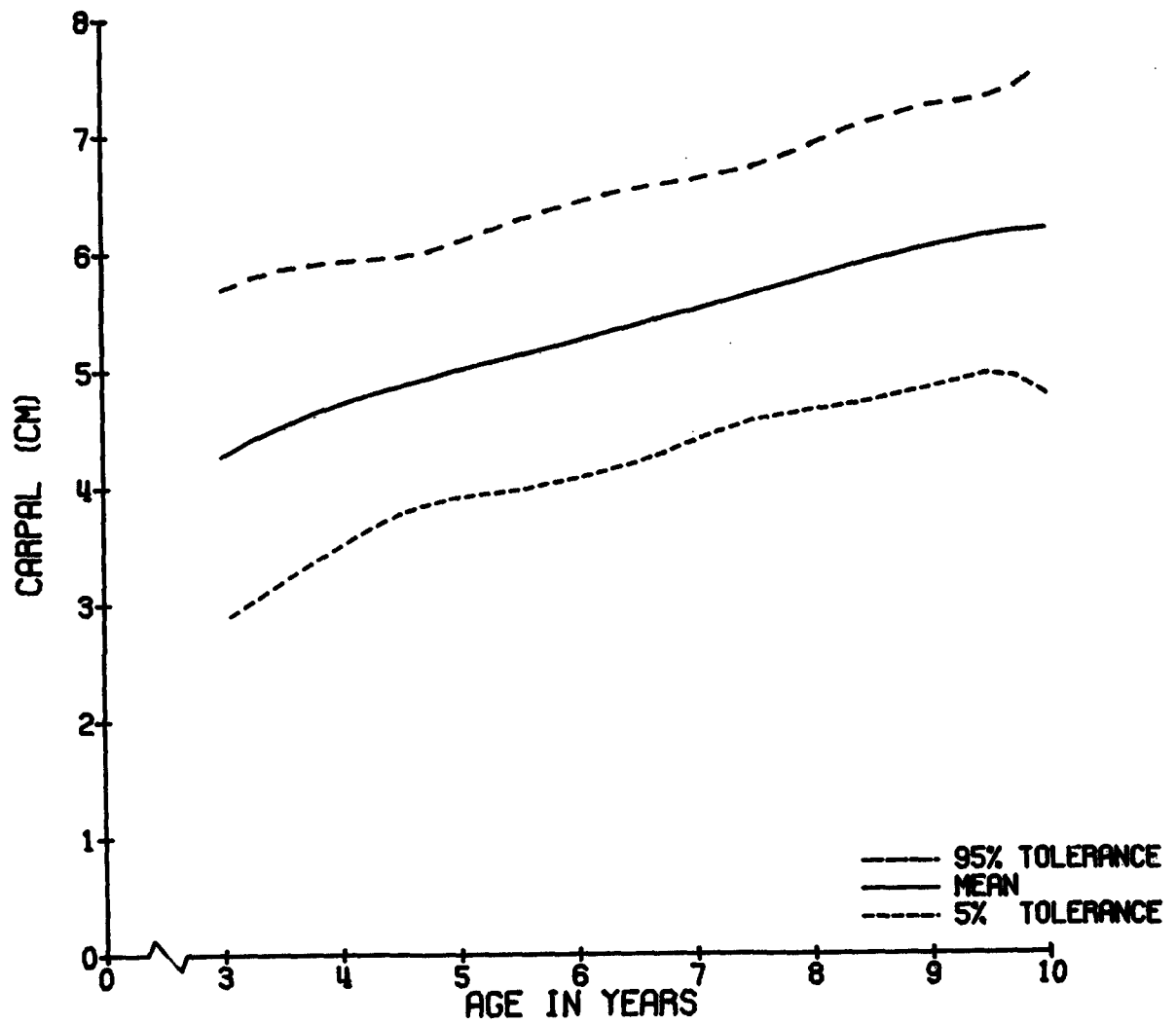

RADIAL LINKAGE

DESCRIPTION: Measure from the elbow joint (humero-ulnar joint center) to the wrist (radiocarpal joint center).

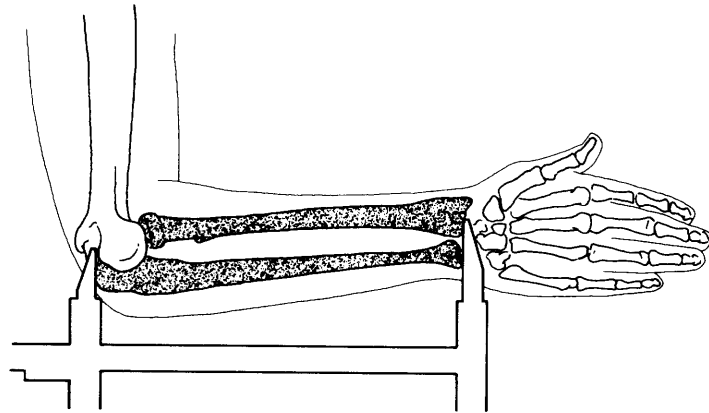
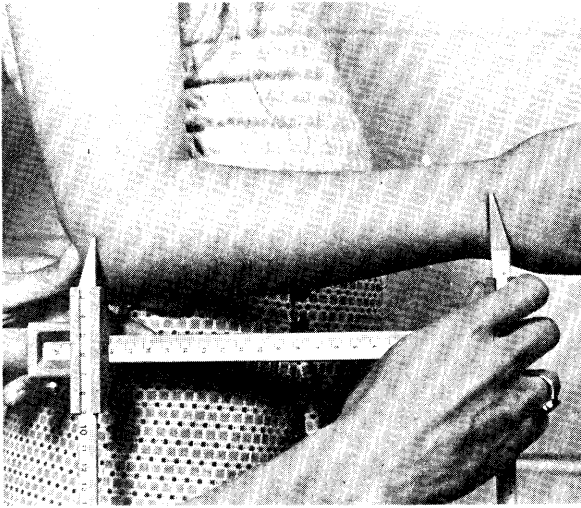

RADIAL (CM)

COMBINED SEXES

AGE	N	MEAN	ST. DEV	MIN	10%	MEDIAN	90%	MAX
3	12	14.0	1.2	12.0	12.5	14.0	15.0	16.5
4	75	14.5	1.1	12.0	13.0	14.5	16.0	18.0
5	82	15.5	1.1	13.5	14.0	15.5	17.0	18.0
6	70	16.9	1.1	14.0	15.5	17.0	18.0	19.5
7	79	17.8	1.3	15.0	16.0	18.0	19.5	20.5
8	71	18.8	1.4	16.5	17.0	19.0	20.5	22.5
9	81	19.7	1.5	17.0	18.0	20.0	22.0	24.0
10	28	20.3	1.5	18.0	18.5	20.3	22.5	23.0

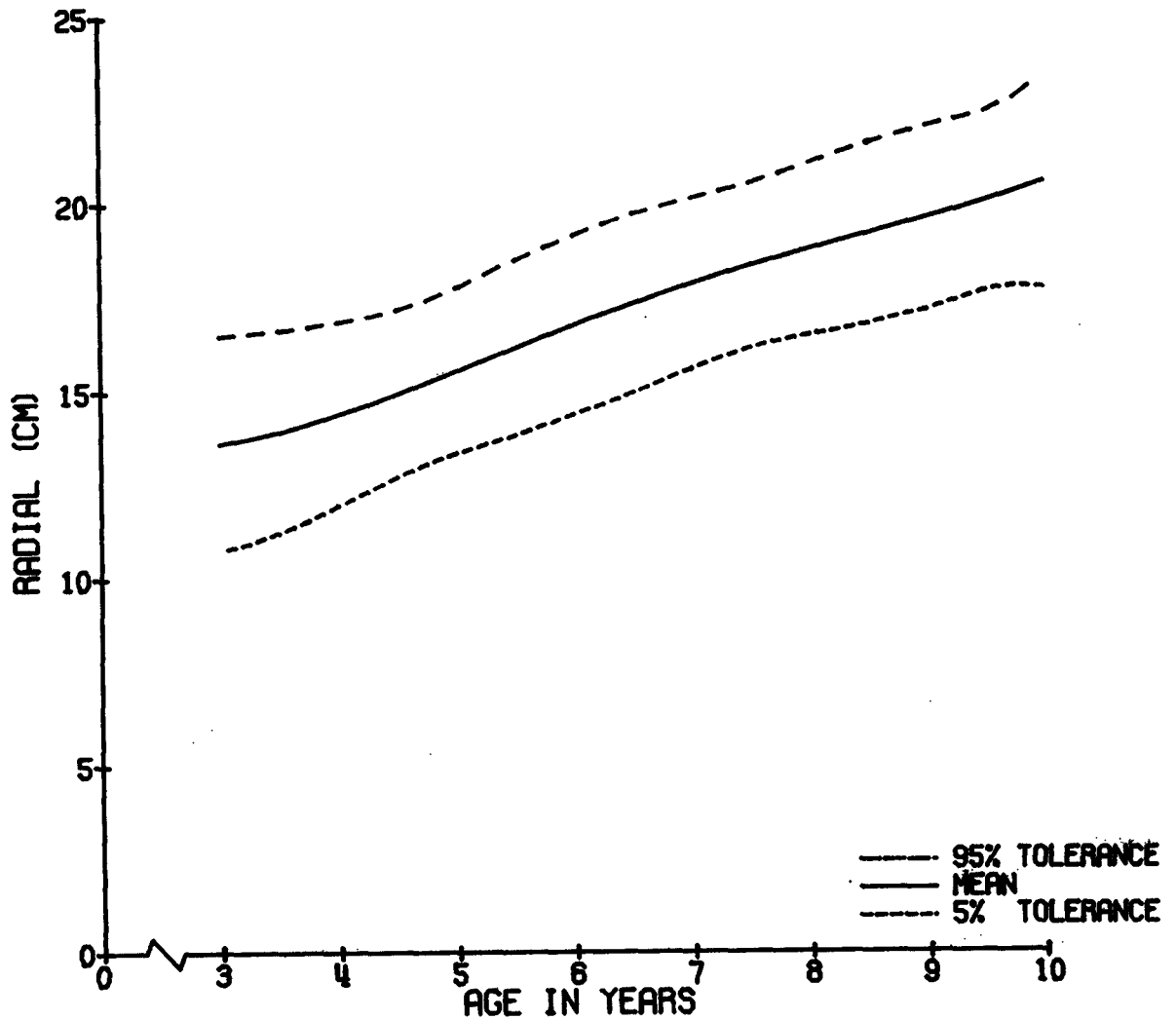

HUMERAL LINKAGE

DESCRIPTION: Measure from the shoulder joint (glenohumeral joint center) to the elbow joint (humero-ulnar joint center).

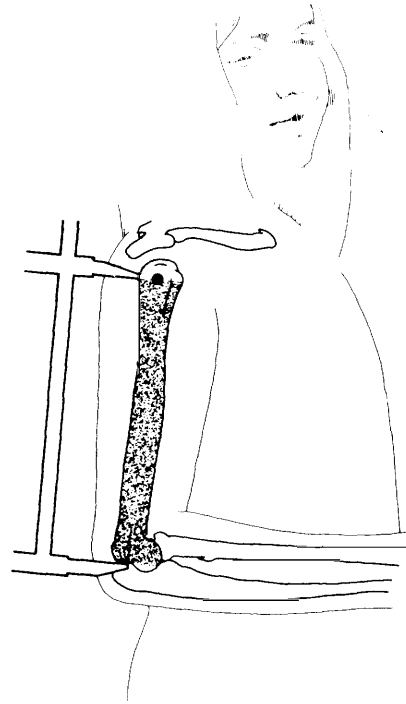
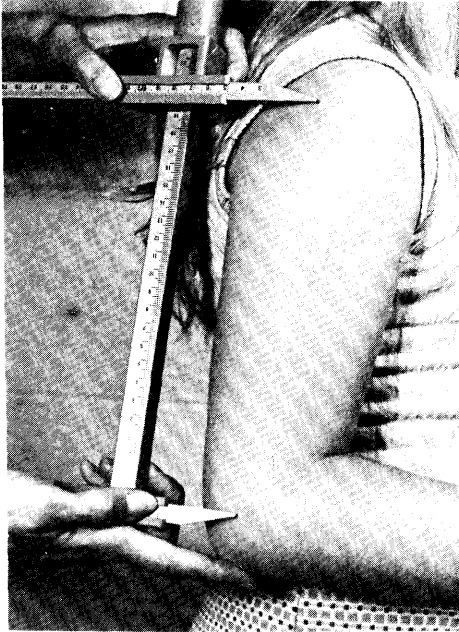

HUMERAL (CM)

COMBINED SEXES

AGE	N	MEAN	ST. DEV	MIN	10%	MEDIAN	90%	MAX
3	12	14.3	1.6	12.5	13.0	14.0	16.0	18.0
4	75	15.3	1.3	12.0	13.5	15.0	17.0	18.0
5	82	16.6	1.5	13.0	15.0	17.0	18.0	20.0
6	70	17.3	1.4	15.5	16.0	18.0	20.0	21.0
7	79	19.3	1.3	16.0	17.5	19.0	21.5	22.0
8	71	20.3	1.4	17.0	19.0	20.0	22.0	24.0
9	81	21.4	1.5	18.0	19.5	21.5	23.0	26.0
10	28	22.1	1.6	19.0	20.0	22.0	24.0	25.0

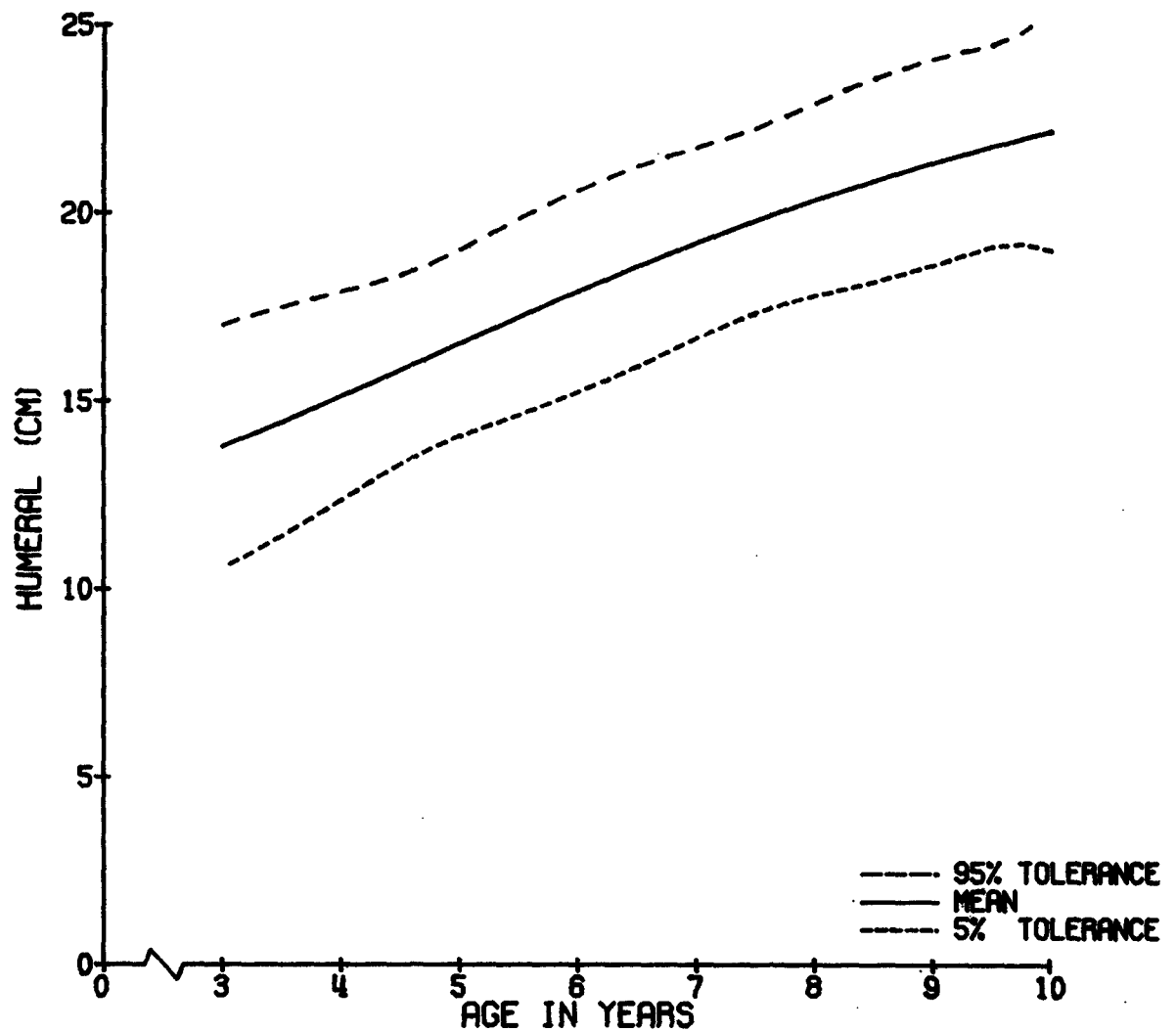

SACRAL LINKAGE

DESCRIPTION: Measure from the hip joint (femoral head) to the hip top (crest of ilium).

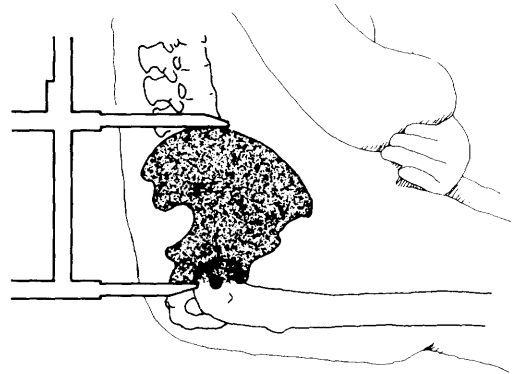
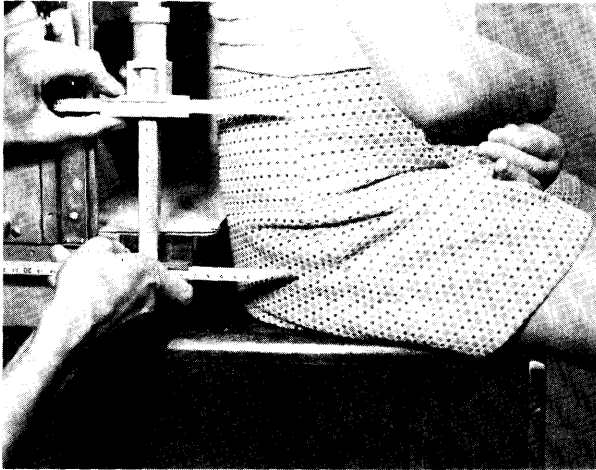

SACRAL (CM)

COMBINED SEXES

AGE	N	MEAN	ST. DEV	MIN	10%	MEDIAN	90%	MAX
3	12	7.6	1.3	6.0	6.5	7.3	9.5	10.0
4	75	7.7	1.0	6.0	7.0	7.5	9.0	11.5
5	82	8.2	1.3	6.0	7.0	8.0	10.0	12.0
6	70	9.2	1.3	6.0	7.0	9.3	11.0	12.0
7	79	8.8	1.7	5.0	6.5	9.0	11.0	12.0
8	71	9.5	1.7	6.5	7.0	10.0	11.0	14.0
9	81	9.9	1.8	5.5	8.0	10.0	12.0	13.5
10	28	10.6	1.5	7.0	9.0	11.0	13.0	13.0

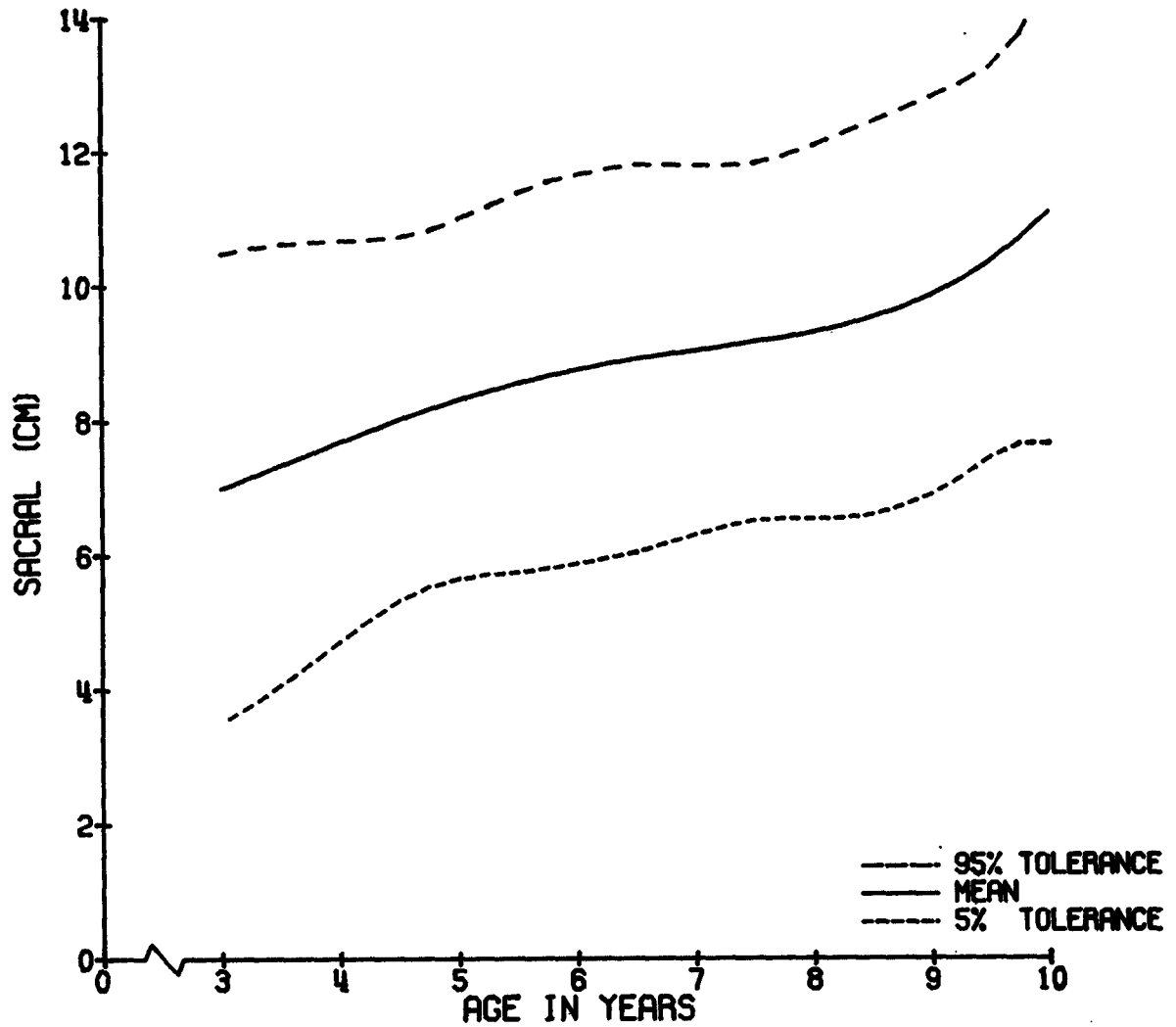

THORACOLUMBAR LINKAGE

DESCRIPTION: Measure from the hip top (crest of the ilium) to the shoulder joint (glenohumeral joint center).

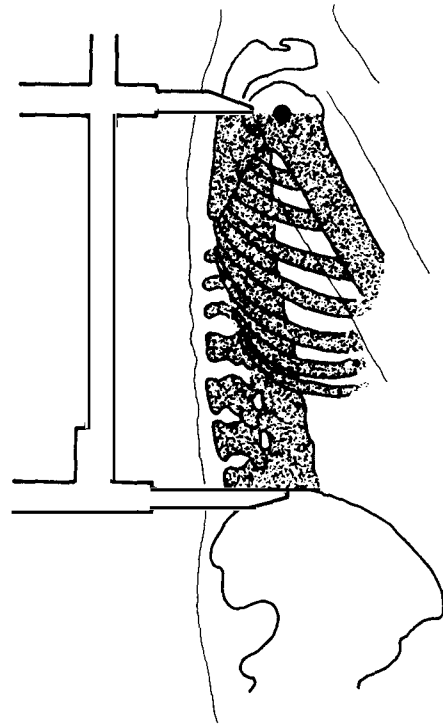

THORACOLUMBAR (CM)

COMBINED SEXES

AGE	N	MEAN	ST. DEV	MIN	10%	MEDIAN	90%	MAX
3	12	20.3	2.7	17.0	18.0	19.5	23.0	26.5
4	75	20.2	2.0	15.5	17.0	20.0	22.5	25.0
5	82	21.3	2.0	15.5	18.5	21.0	24.0	26.0
6	70	22.1	2.2	17.0	19.0	22.0	25.0	27.0
7	79	23.8	2.2	19.0	21.0	24.0	26.0	28.5
8	71	25.3	2.0	19.0	23.0	25.0	28.0	30.5
9	81	26.2	2.7	21.5	23.0	26.0	29.0	36.5
10	28	27.6	2.5	22.0	23.0	28.0	31.0	33.0

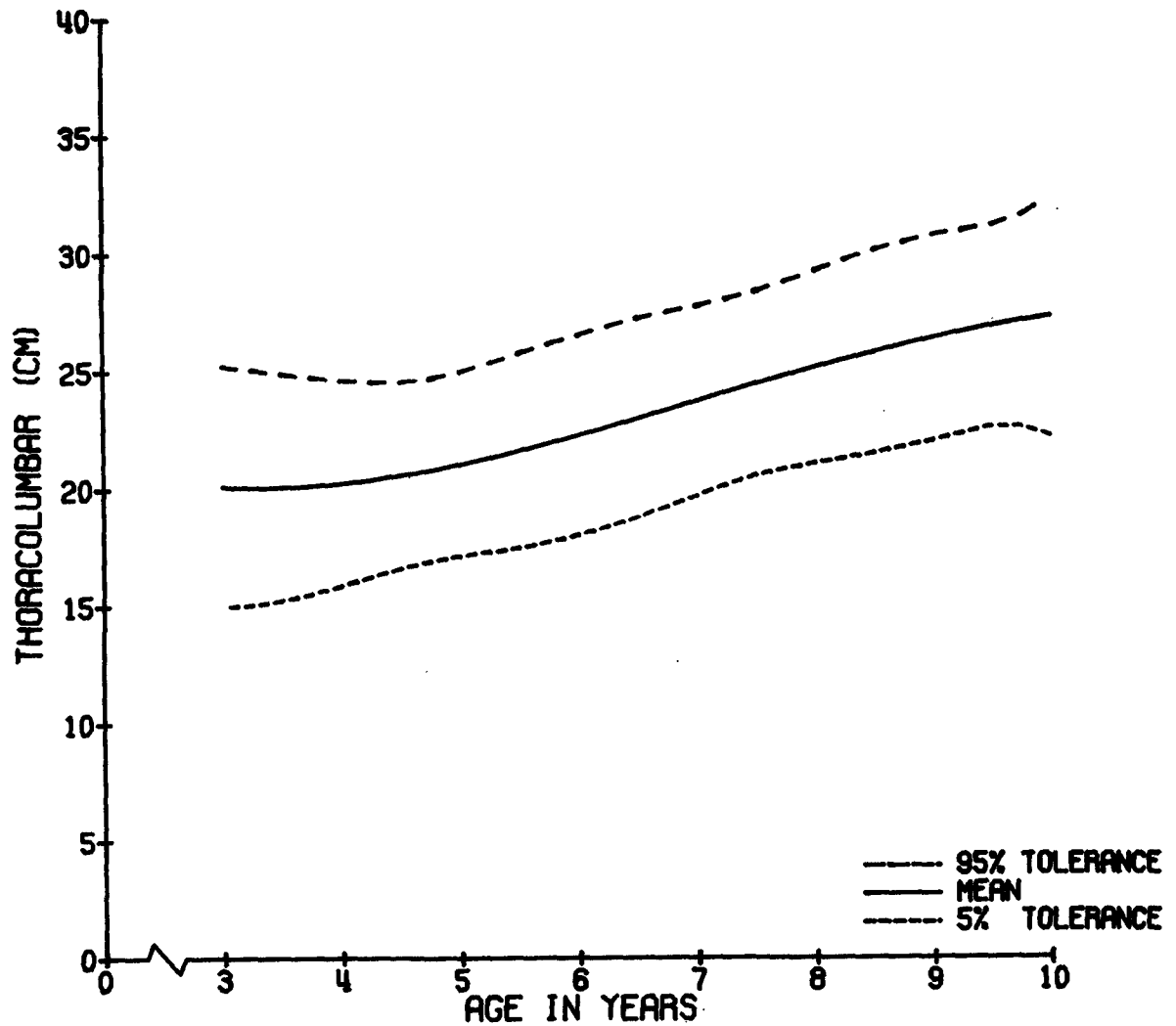

CERVICAL LINKAGE

DESCRIPTION: Measure from the shoulder joint (glenohumeral joint center) to the ear canal (external auditory meatus).

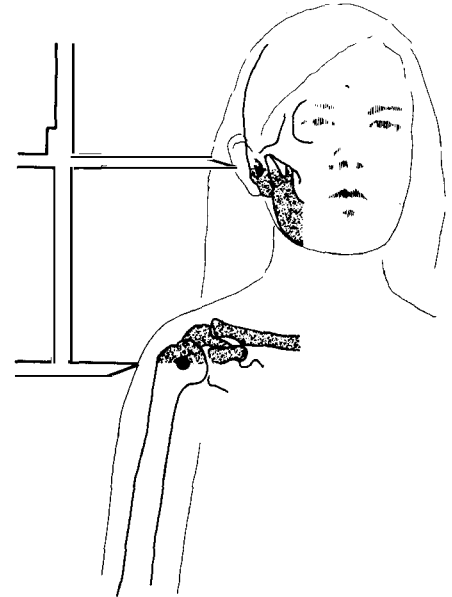
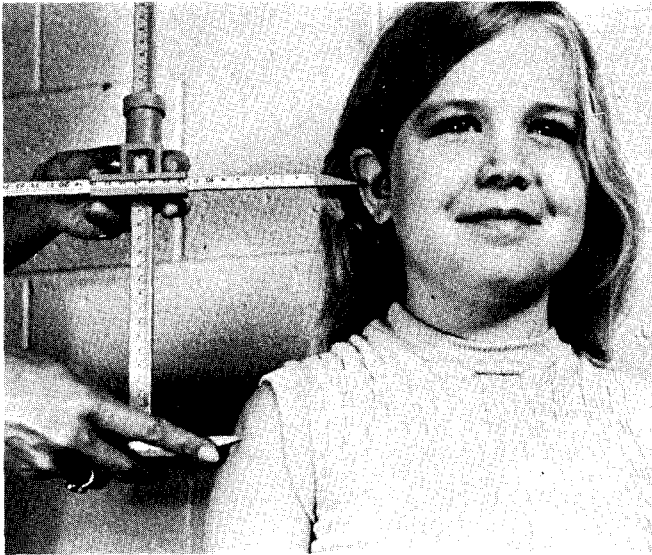

CERVICAL (CM)

COMBINED SEXES

AGE	N	MEAN	ST. DEV	MIN	10%	MEDIAN	90%	MAX
3	12	12.3	1.3	9.5	11.0	12.5	13.5	14.5
4	75	12.5	1.4	10.0	11.0	12.0	14.5	16.0
5	82	13.2	1.8	9.5	11.0	13.0	15.5	18.0
6	70	13.5	1.3	11.0	12.0	13.5	15.0	17.0
7	79	14.3	1.4	10.0	12.5	14.0	16.0	17.5
8	71	15.5	1.6	11.0	14.0	15.5	17.0	20.5
9	81	15.9	1.9	11.5	14.0	16.0	18.0	20.5
10	28	16.5	1.7	13.0	14.5	16.8	19.0	20.0

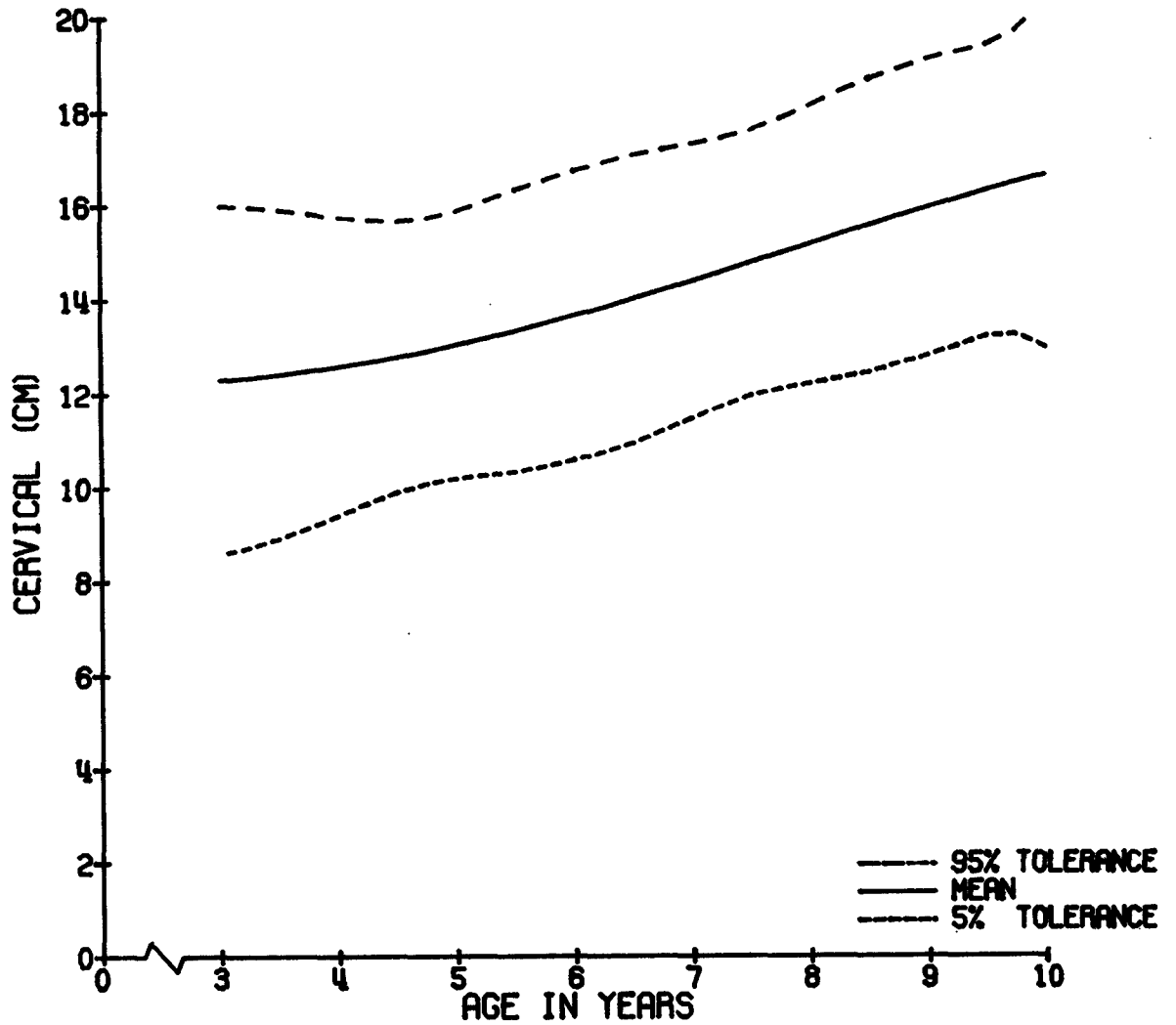

FEMORAL LINKAGE

DESCRIPTION: Measure from the hip joint to the knee joint (femorotibial joint center).

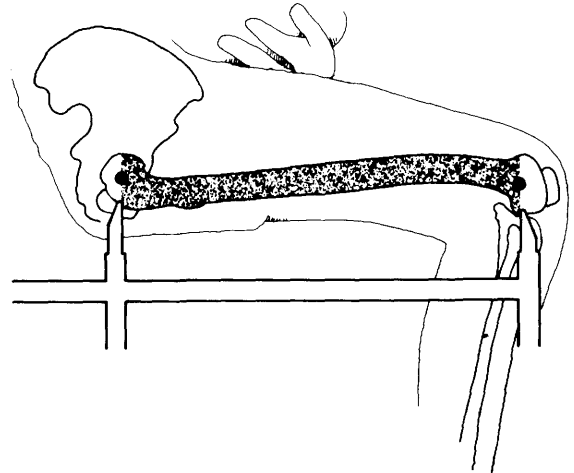
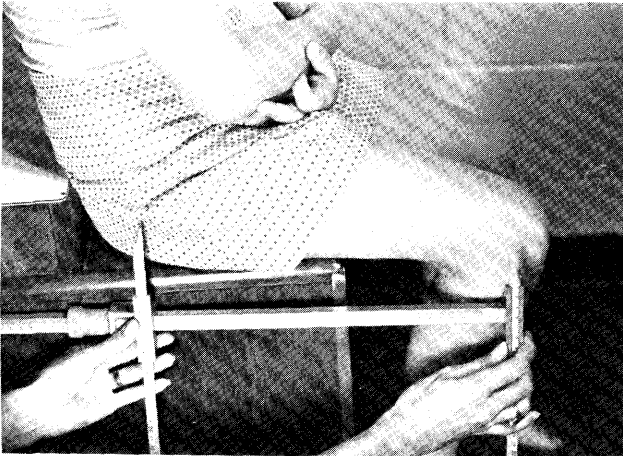

FEMORAL (CM)

COMBINED SEXES

AGE	N	MEAN	ST. DEV	MIN	10%	MEDIAN	90%	MAX
3	12	23.5	1.6	21.0	21.5	24.0	25.0	27.0
4	75	25.7	1.9	21.5	23.0	26.0	28.0	30.0
5	82	27.3	2.0	23.0	25.0	27.0	30.0	32.0
6	70	29.9	2.4	25.0	27.0	30.0	33.0	35.0
7	79	32.4	2.3	26.0	29.0	33.0	35.0	38.0
8	71	34.5	2.8	28.0	31.0	35.0	39.0	40.0
9	81	36.0	2.7	30.0	33.0	36.0	39.0	44.0
10	28	37.8	2.3	31.5	35.0	37.5	41.0	42.0

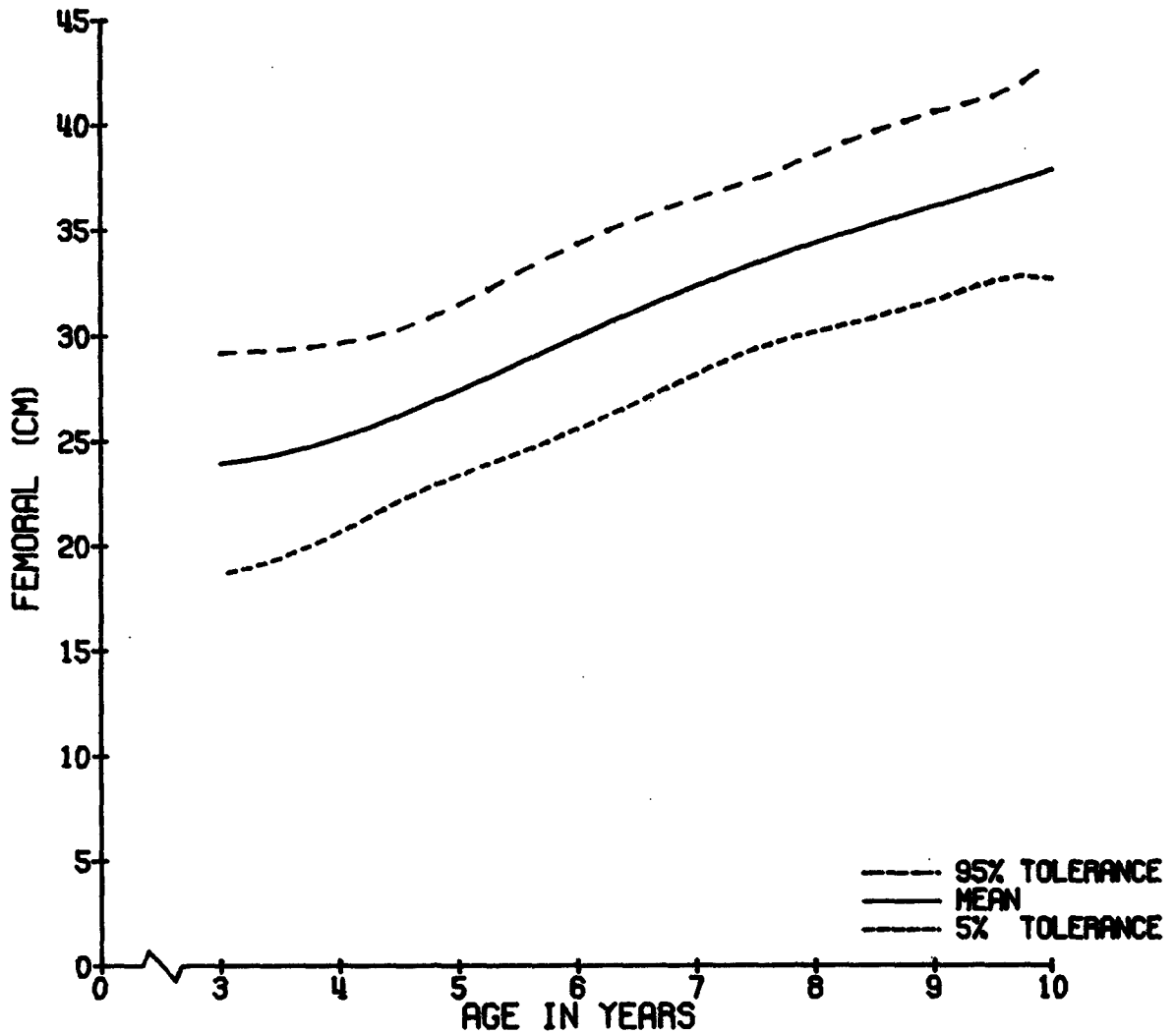

TIBIAL LINKAGE

DESCRIPTION: Measure from the ankle joint (tibiotalar joint center) to the knee joint (femorotibial joint center).

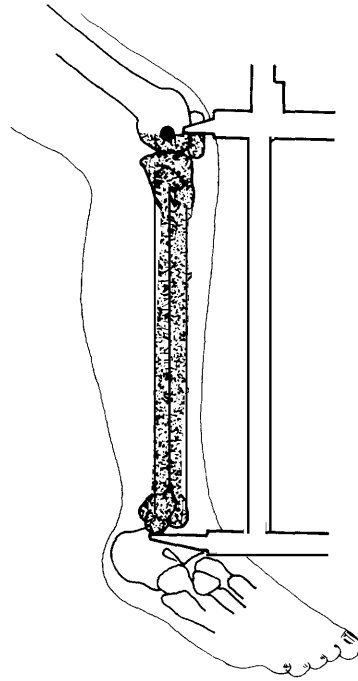
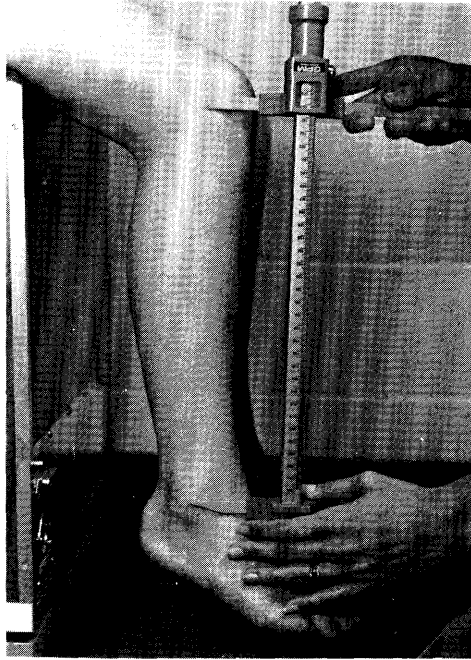

TIBIAL (CM)

COMBINED SEXES

AGE	N	MEAN	ST. DEV	MIN	10%	MEDIAN	90%	MAX
3	12	22.0	2.1	19.0	20.0	21.8	25.0	25.0
4	75	23.3	1.4	20.0	21.0	23.0	25.0	26.0
5	82	25.4	1.9	21.0	23.0	25.5	28.0	31.0
6	70	27.4	1.7	24.0	25.0	27.0	29.0	33.0
7	79	29.5	1.9	23.0	28.0	29.0	32.0	33.5
8	71	31.3	2.2	27.0	28.5	31.0	34.0	37.0
9	81	32.8	2.4	27.5	29.5	33.0	35.0	39.0
10	28	34.0	2.4	29.0	31.0	34.0	37.0	41.0

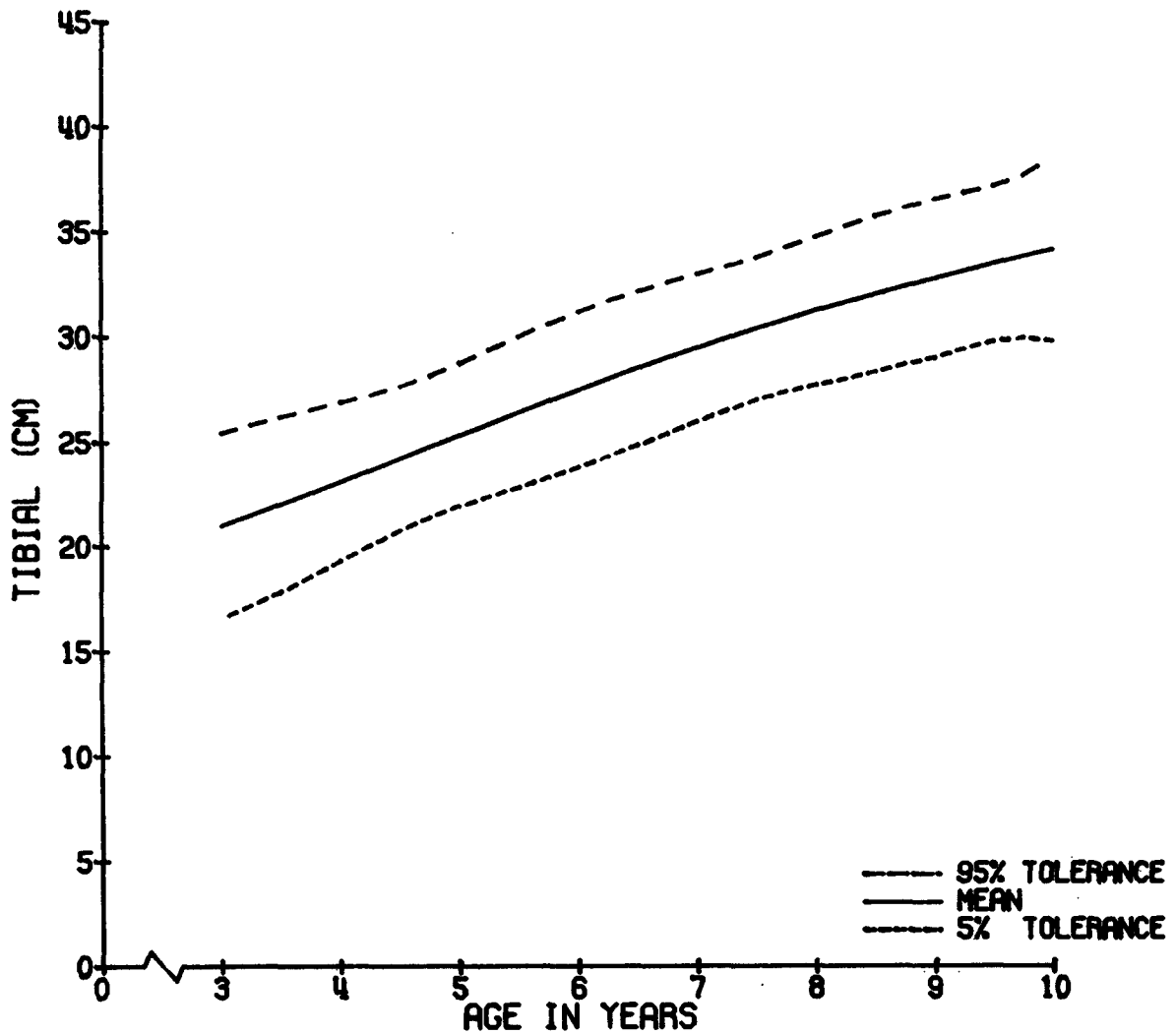

TARSAL LINKAGE

DESCRIPTION: Measure from the ball of the foot (first tarso-phalangeal joint center) to ankle joint (tibio-tarsal joint center).

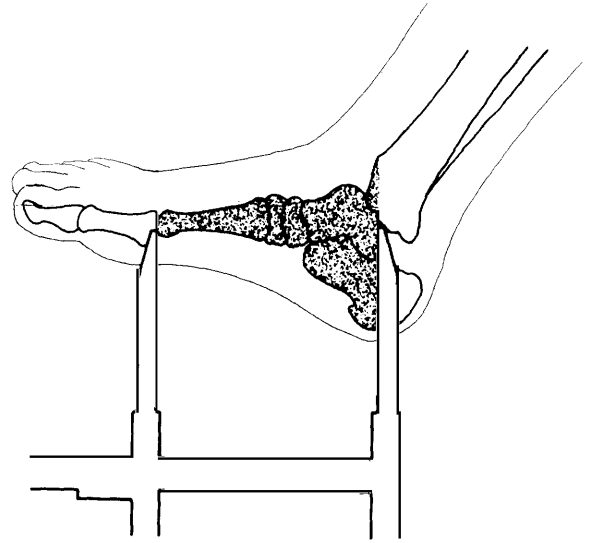
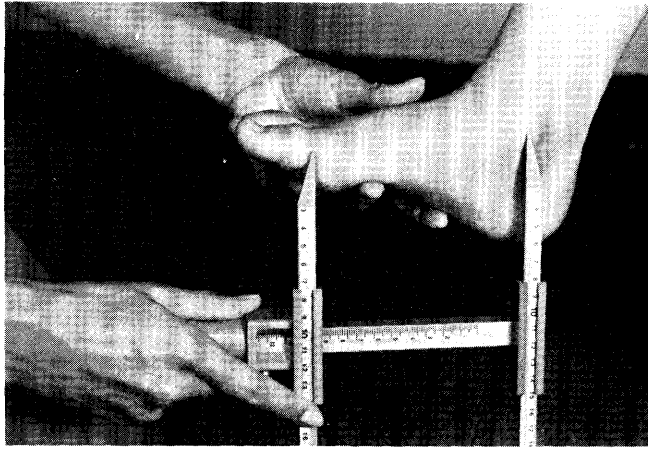

TARSAL (CM)

COMBINED SEXES

AGE	N	MEAN	ST. DEV	MIN	10%	MEDIAN	90%	MAX
3	12	8.9	0.9	8.0	8.0	9.0	10.0	10.0
4	75	9.5	0.6	8.0	9.0	9.5	10.0	11.0
5	82	10.1	1.0	8.0	9.0	10.0	11.0	13.0
6	70	10.7	1.1	7.0	9.0	11.0	12.0	13.0
7	79	11.6	1.1	9.0	10.0	11.5	13.0	14.0
8	71	12.3	1.0	11.0	11.0	12.0	14.0	14.5
9	81	12.4	1.2	8.0	11.0	12.0	14.0	15.0
10	28	12.9	1.2	11.0	11.0	13.0	15.0	15.0

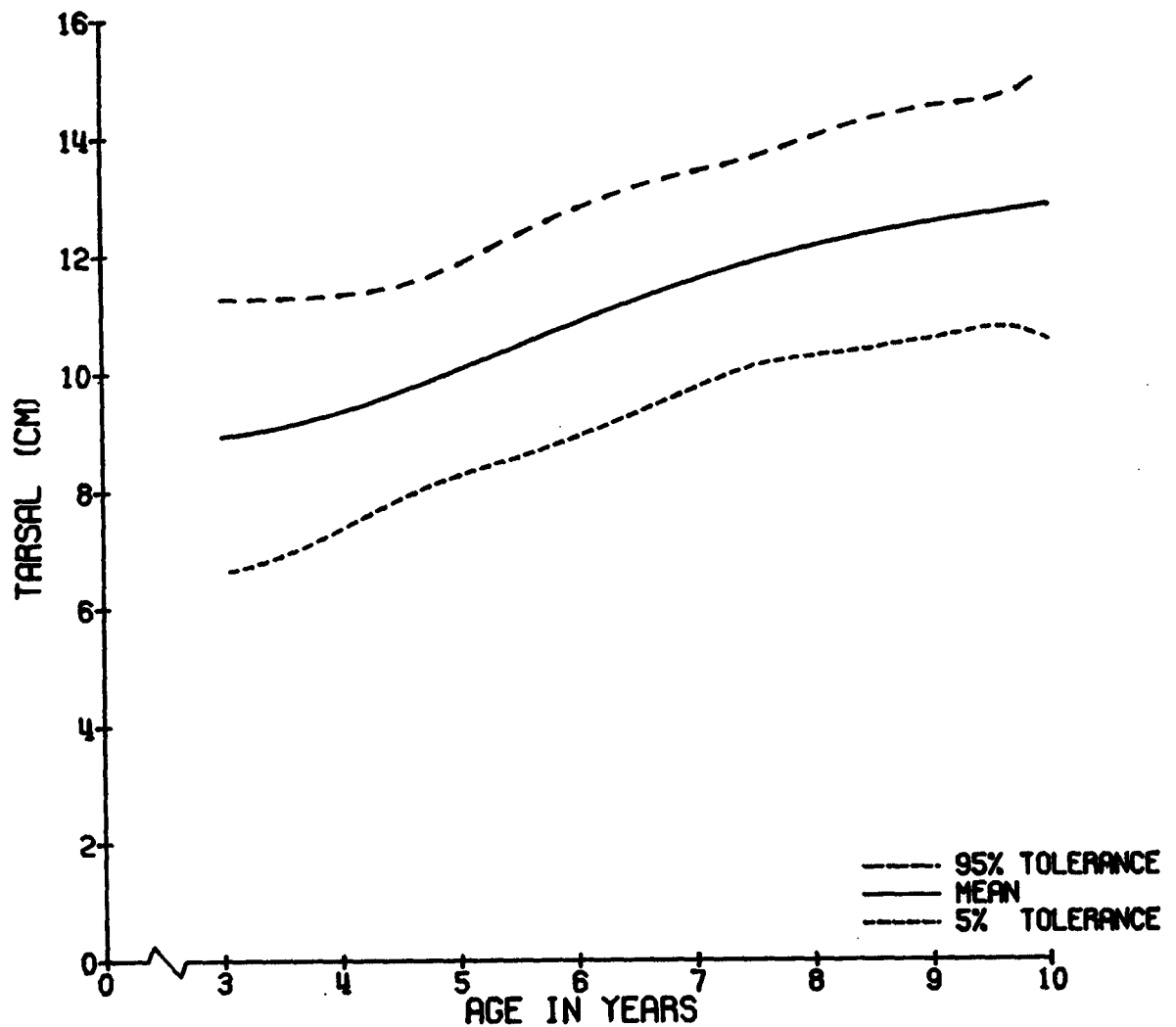

CLAVICLE LINKAGE

DESCRIPTION: Measure from the left shoulder joint (left glenohumeral joint) to the right shoulder joint (right glenohumeral joint center). Subject standing.

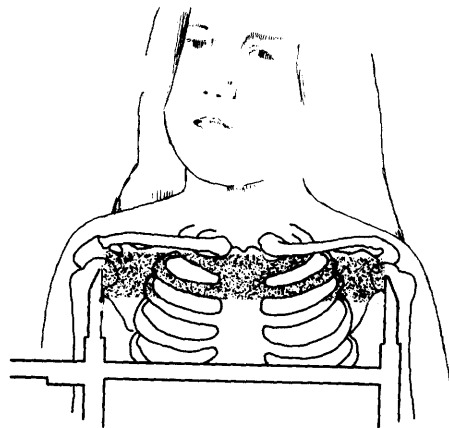
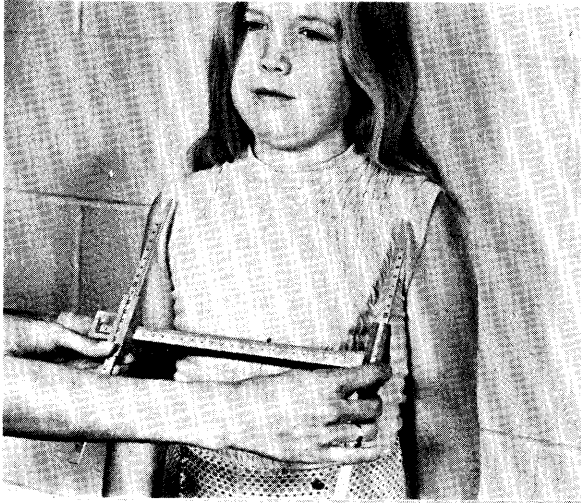

CLAVICLE (CM)

COMBINED SEXES

AGE	N	MEAN	ST. DEV	MIN	10%	MEDIAN	90%	MAX
3	12	16.6	1.2	15.0	15.0	16.8	17.5	19.0
4	75	17.5	1.4	14.0	16.0	17.0	19.0	20.5
5	82	18.0	1.3	15.0	16.0	18.0	19.5	21.5
6	70	18.7	1.4	15.0	17.0	19.0	20.5	22.0
7	79	19.0	1.4	16.0	17.5	19.0	21.0	23.0
8	71	20.4	1.5	18.0	19.0	20.0	22.5	24.0
9	81	20.8	1.8	16.5	18.5	21.0	23.0	25.0
10	28	21.0	1.6	19.0	19.5	20.5	24.0	25.0

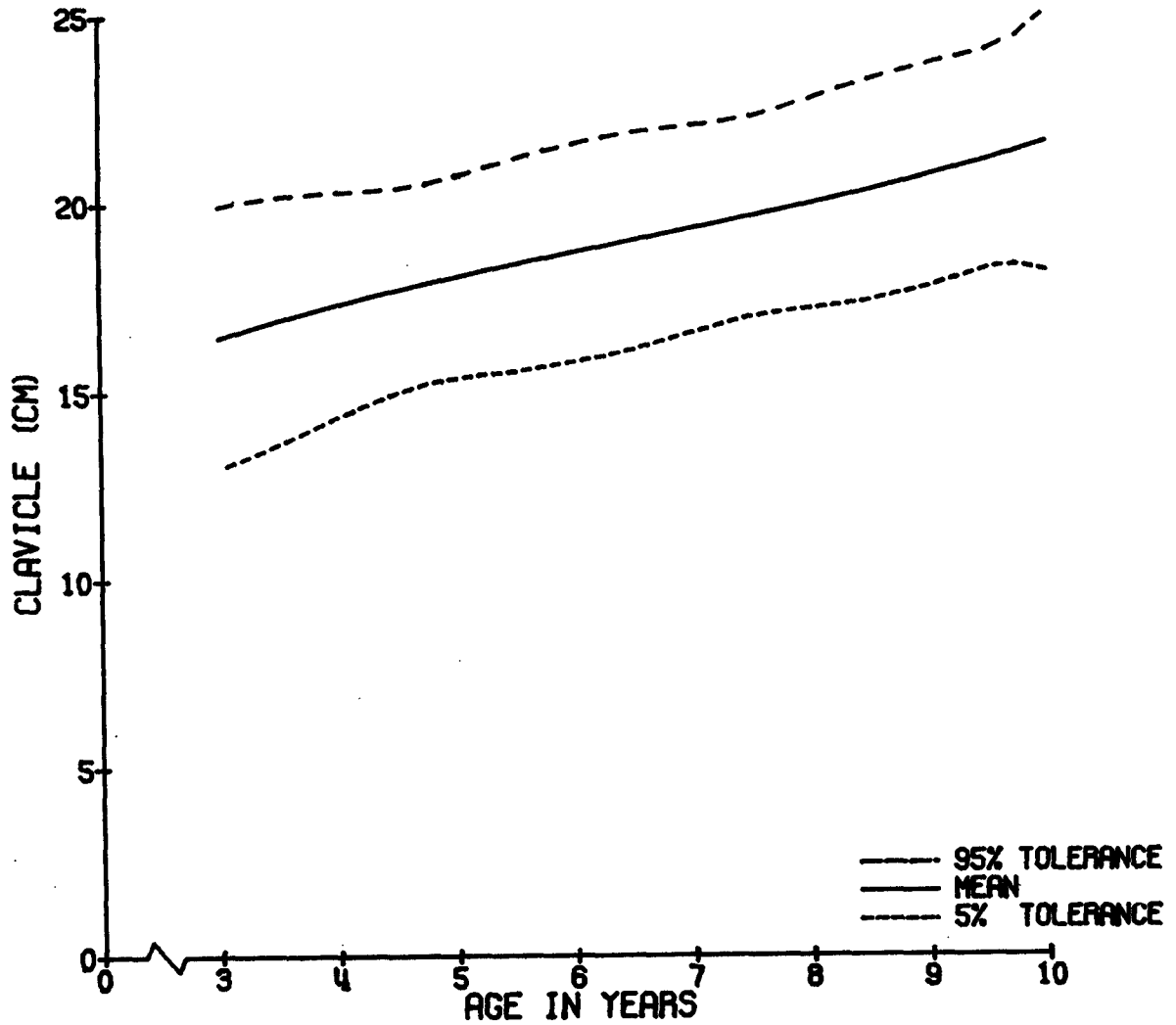

PELVIC LINKAGE

DESCRIPTION: Measure from the left hip joint (left femoral head) to the right hip joint (right femoral head). Subject standing.

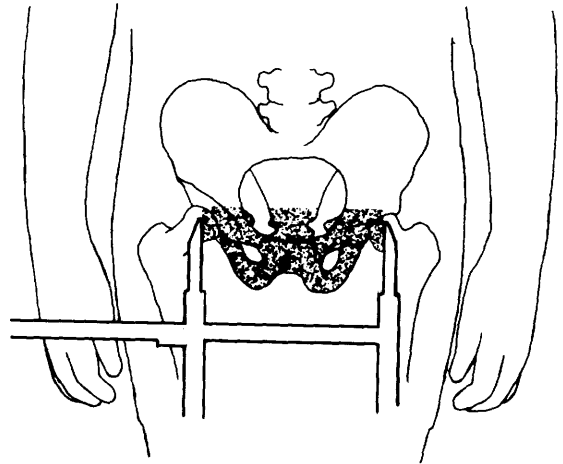
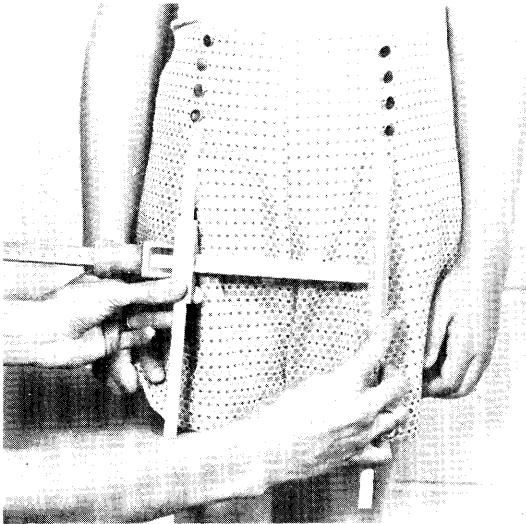

PELVIC (CM)

COMBINED SEXES

AGE	N	MEAN	ST. DEV	MIN	10%	MEDIAN	90%	MAX
3	12	14.3	1.4	12.0	12.0	14.8	15.0	17.0
4	75	15.7	1.3	12.5	14.0	16.0	17.0	19.0
5	82	16.1	1.3	13.0	14.0	16.0	17.5	19.0
6	70	16.6	1.1	14.0	15.0	17.0	18.0	19.0
7	79	17.3	1.1	14.0	16.0	17.0	19.0	20.0
8	71	18.2	1.5	15.5	17.0	18.0	19.5	26.0
9	81	18.7	1.5	15.0	17.0	19.0	20.5	23.0
10	28	18.9	1.3	15.5	17.0	19.0	20.5	21.5

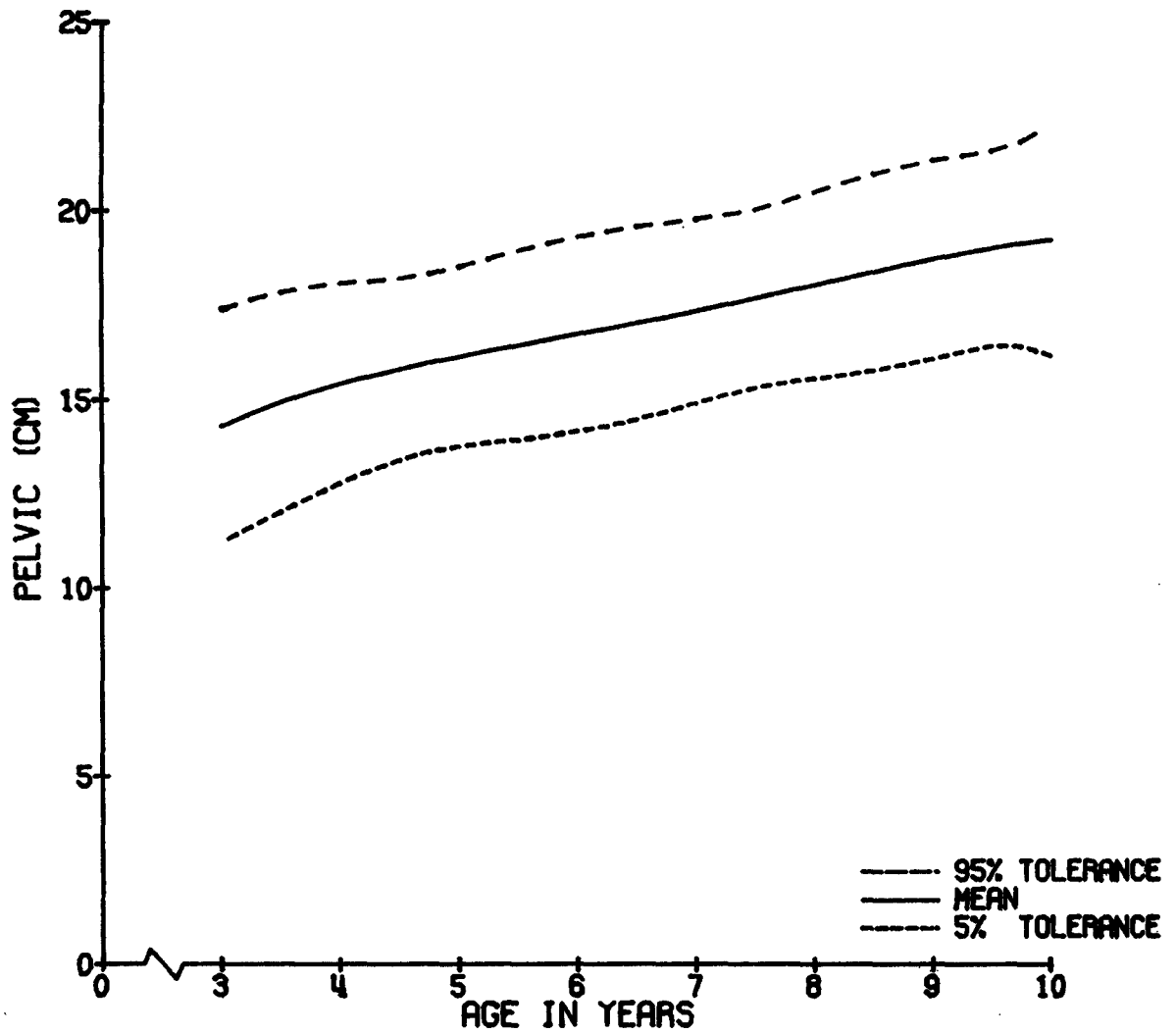

STANDING HEIGHT

DESCRIPTION: Measure the perpendicular distance from the floor to the vertex with the child standing in bare feet or socks.

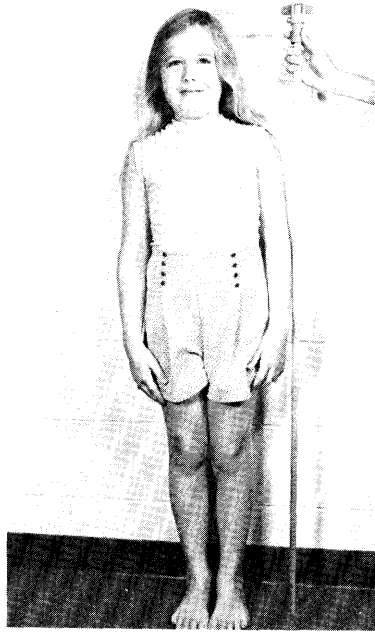

STANDING HEIGHT (CM)

COMBINED SEXES

AGE	N	MEAN	ST. DEV	MIN	10%	MEDIAN	90%	MAX
3	12	95.2	6.6	85.0	89.5	93.0	103.0	108.0
4	75	101.6	4.9	82.0	95.5	102.0	107.0	112.0
5	82	108.6	5.4	96.0	101.5	109.0	115.5	122.5
6	70	113.9	4.8	102.0	108.5	113.5	120.0	125.5
7	79	120.4	5.1	100.0	114.5	120.5	127.0	132.5
8	71	127.3	5.7	114.0	121.5	127.0	134.5	144.0
9	81	131.5	7.2	115.5	121.5	132.0	140.0	152.0
10	28	136.3	6.5	121.0	126.0	137.5	144.5	149.0

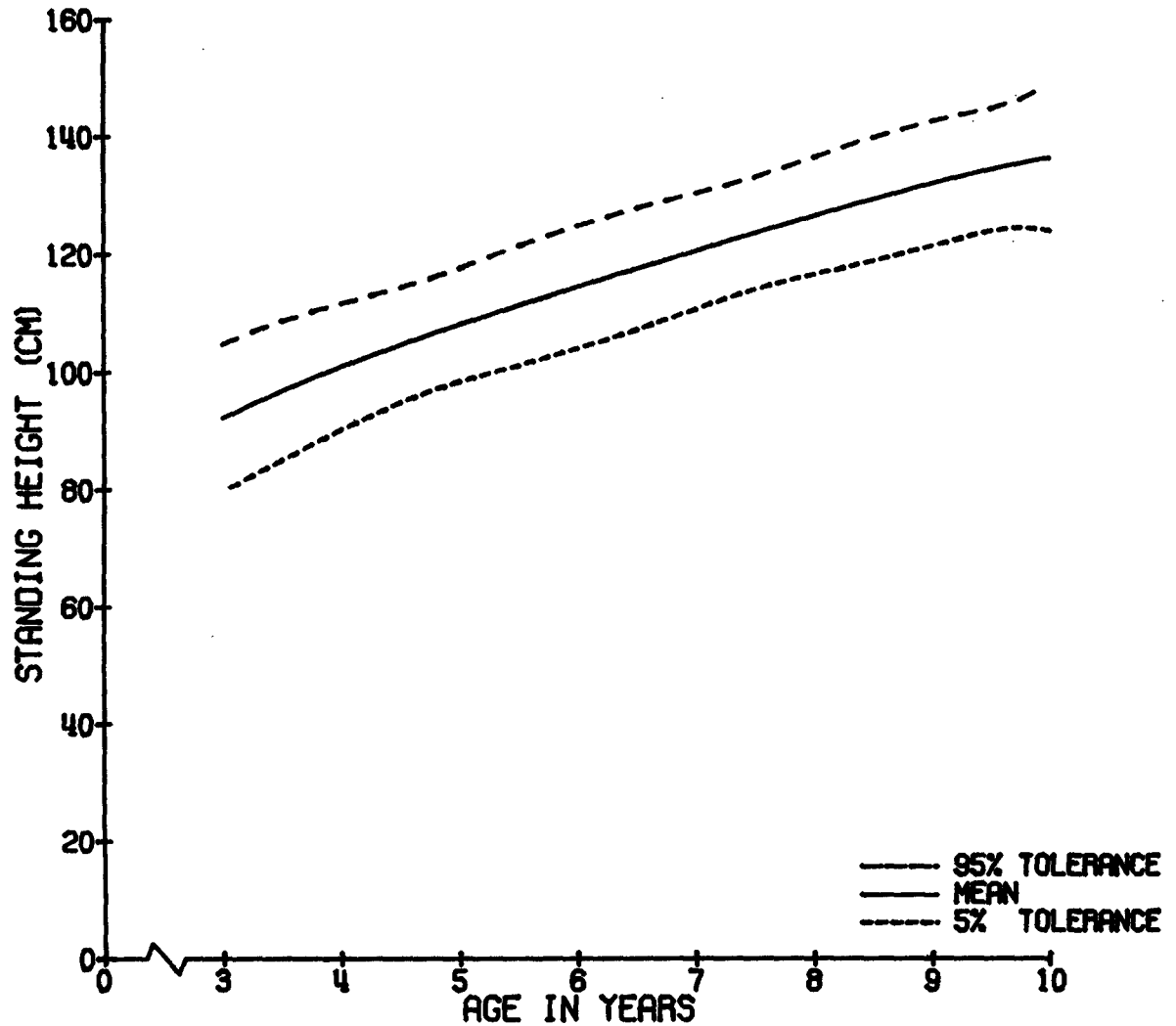

BODY WEIGHT

DESCRIPTION: Seat subject on back side of chair with shoes off. Computer records voltage output from all four load cells supporting the chair. Remove the subject from chair. Computer similarly records empty chair weight. The difference between the two readings, the child's weight, is displayed on the graphics terminal and is stored.



BODY WEIGHT (KG)

COMBINED SEXES

AGE	N	MEAN	ST. DEV	MIN	10%	MEDIAN	90%	MAX
3	12	14.6	2.4	10.7	12.4	14.0	18.3	18.8
4	75	16.7	2.3	12.7	14.0	16.5	19.4	26.8
5	82	18.5	2.7	12.7	15.5	18.0	21.9	27.7
6	70	20.2	2.6	10.9	17.2	20.5	23.7	26.3
7	79	23.9	3.4	15.8	20.0	23.8	29.2	33.4
8	71	27.5	4.5	19.8	22.7	27.1	33.3	42.4
9	81	29.7	5.3	20.1	23.2	29.1	35.1	46.6
10	28	32.2	6.0	21.6	25.9	32.5	38.4	53.1

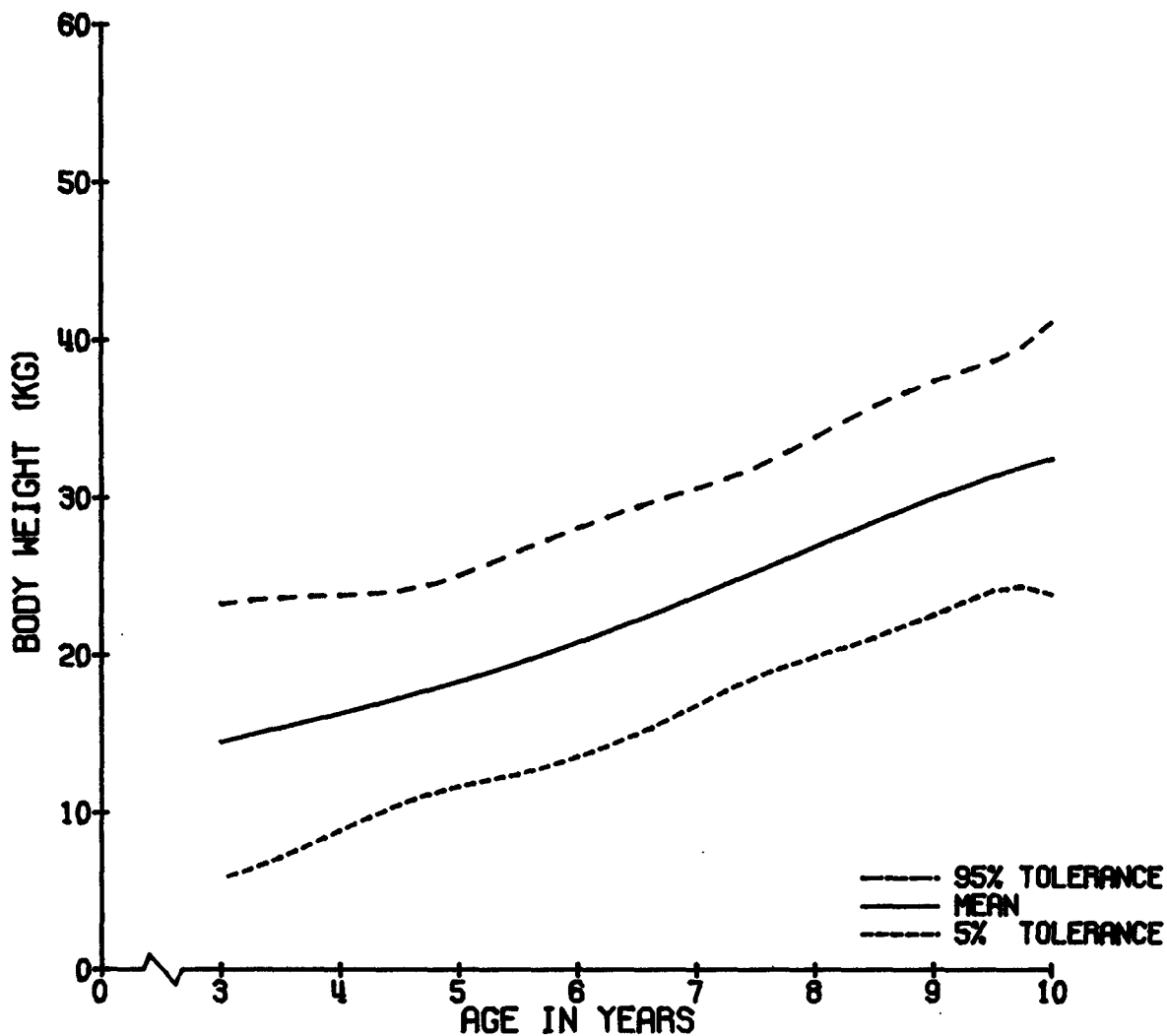

4.1. STATIC ANALYSIS OF STRENGTH CHAIR

NOTE: Refer to the limb and limb fixture shown in Figure 4.1.1.

The sum of the moments about any point on a body in static equilibrium must equal zero. A free body diagram of the limb can be drawn showing all the forces acting on the limb (excluding gravitational effects):

Note: F_{AX} \equiv force on A in the X direction, etc.

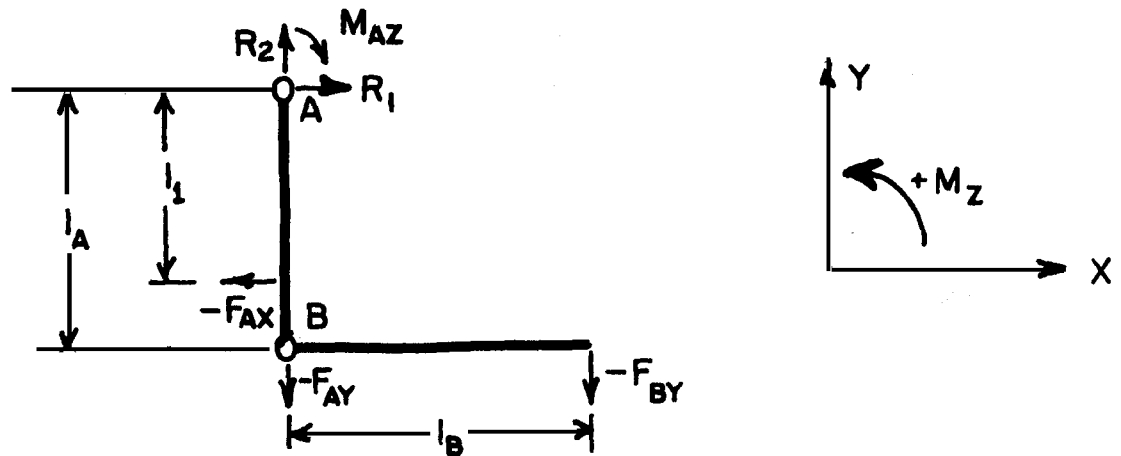

Summing the moments about joint A:

$$\sum M_{AZ} = -(-F_{AX}l_1) - (-F_{BY}l_B) - M_{AZ} = 0$$

$$M_{AZ} = F_{AX}l_1 + F_{BY}l_B$$

Equation #1

Similarly, a free body diagram of the limb fixture can be drawn:

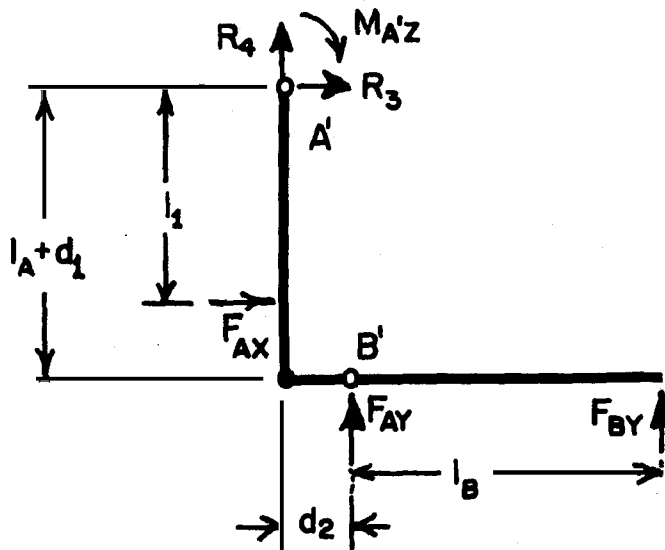

Summing the moments about point A':

$$\Sigma M_{A'Z} = F_{AX}\ell_1 + F_{BY}(\ell_B + d_2) + F_{AY}d_2 - M_{A'Z} = 0$$

$$M_{A'Z} = F_{AX}\ell_1 + F_{BY}\ell_B + (F_{AY} + F_{BY})d_2 \quad \text{Equation \#2}$$

Solving Equations #1 and #2 simultaneously

$$M_{AZ} = M_{A'Z} - F_{AY}d_2 - F_{BY}d_2 \quad \text{Equation \#3}$$

Since $M_{A'Z}$ is the bending moment to which gage set A will respond and M_{AZ} is the "strength" about joint A, the strain gage set at A provides an adequate measure of the torque generated about joint A providing the error terms $F_{AY}d_2$ and $F_{BY}d_2$ are small or can be approximated by either of the following methods:

- 1) By design $d_2 \ll \ell_B$ and the approximation may be made

$$F_{BY}\ell_B \gg F_{BY}d_2 \approx 0 \quad \text{and Equation \#3 becomes}$$

$$M_{AZ} = M_{A'Z} - F_{BY}d_2 \quad \text{Equation \#4}$$

- 2) F_{BX} may be measured by the gage set at B' where

$$M_{BZ} = M_{B'Z} \quad \text{exactly and } F_{BY} = \frac{M_{B'Z}}{\ell_B}$$

Substituting this relation into Equation #4 gives

$$M_{AZ} = M_{A'Z} - M_{B'Z} \frac{d_2}{\ell_B} \quad \text{Equation \#5}$$

Where: $M_{A'Z}$ = output of gage set A

$M_{B'Z}$ = output of gage set B

ℓ_B = known linkage measurement

d_2 = known constant

Method (2) is conveniently used since the secondary channels were sampled specifically to provide the required additional data, i.e., the simultaneous torque about the more distal joints. For the hip and shoulder joints, a cascaded error term is generated.

Sampling the more distal joints allows for precise calculation of the error terms.

Finally, it should be noted that these error terms arise only when the axis of rotation does not pass through the gage set used for measurement. It is implied that when a gage set does not align with the axis in one plane, it does in a perpendicular plane and no error term exists for strength measurement in that perpendicular plane. This general example was chosen to exemplify error terms which generally arise only in sagittal plane strength measurements (by chair design).

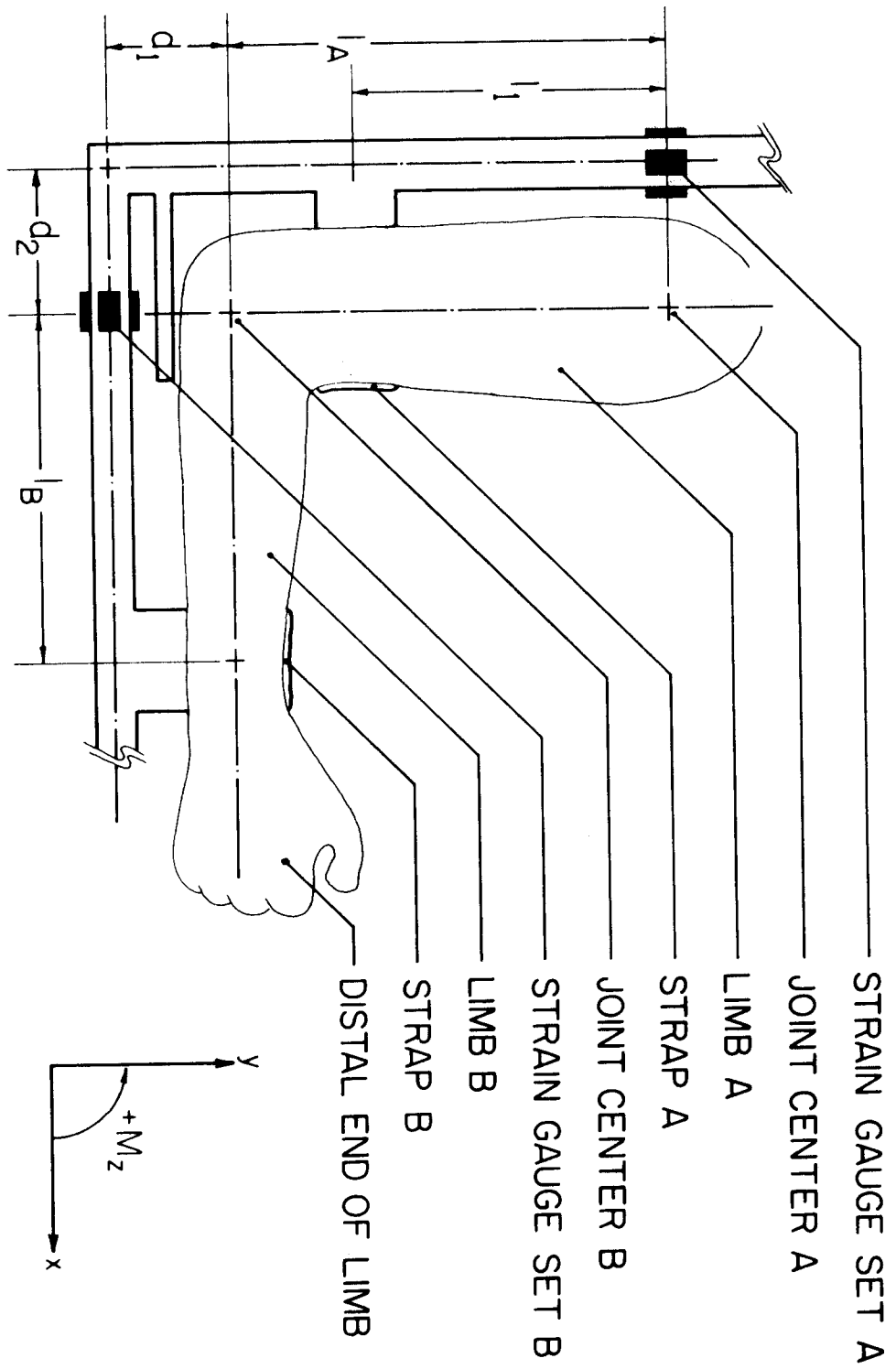

Figure 4.1.1.1. Diagram of Limb and Limb Fixture

4.2. Sample Data Plots: Strength vs Time

Figures 4.2.1. and 4.2.2. are computer generated strength vs time plots of data as they are originally recorded in a test session. Each plot consists of 100 (20/sec) discrete data points plotted as a continuous curve by linearly interpolating between points. These particular tests were performed by a nine year old right-handed female subject weighing 27.4 kp and 130.5 cm tall. Both tests, elbow flexion and extension, were performed with the elbow flexed 90° and were the fifth and sixth tests, respectively, in this particular test session. Three secondary channels, wrist abduction/adduction, shoulder flexion/extension, and hip flexion/extension were simultaneously recorded along with the elbow flexion/extension channel. Their 5 second mean values are listed in the table above the graph along with their respective resting weight readings. The signs in parentheses (+) indicate that the exertion as listed in the table should have a positive value and plotted on the graph as a solid line. Negative values are plotted as broken lines, as in the elbow extension test. Inspection of the table for the elbow flexion test indicates that while the subject was flexing her elbow she was also abducting her wrist, flexing her shoulder, and extending her hip. A graph plotted with respect to the zero baseline: "Z" (no subject in chair) and also with respect to the resting weight baseline: "W" (subject relaxed in chair) is shown in Figure 4.2.3. Notice a greater actual muscular torque is observed for elbow flexion when the data are plotted with respect to the resting weight baseline.

This is because part of the actual muscular effort must be used to overcome the resting weight of the forearm.

Although the resting limb weight is relatively small for elbow flexion/extension exertions as in this test, its magnitude is significant in tests such as hip flexion/extension. This can be easily seen in the hip data recorded from this test.

The results of the 1 second moving point average strength criterion (section 2.6) are also indicated on the graph. In the elbow flexion test presented here, the interval averaged begins at 0.7 seconds and ends at 1.7 seconds.

Figure 4.2.4 is the same elbow flexion graph with all four channels plotted on a single axis. It should be noted that the same 1 second interval chosen from the primary data channel (channel 2 in this test) is also used to analyze performance monitored by the secondary channels. The secondary strength values used in the data reduction were obtained in this manner.

*** FA0129 6/9/75 (9/6/67) 130.5 CM 27.3969 KG R HAND ***
 *** TEST 200 : ELBOW FLEXION (90) SEQUENCE # 5 ***

CHANNEL	FUNCTION	MEAN (KG-CM)	RESTING MEAN (KG-CM)
2	(+) ELBOW FLEXION	237.017	-8.07928
0	(+) WRIST FLEXION	2.49359	-5.95085E-2
4	(+) SHOULDER FLEXION	157.793	-15.6483
11	(+) HIP FLEXION	-517.682	-133.309

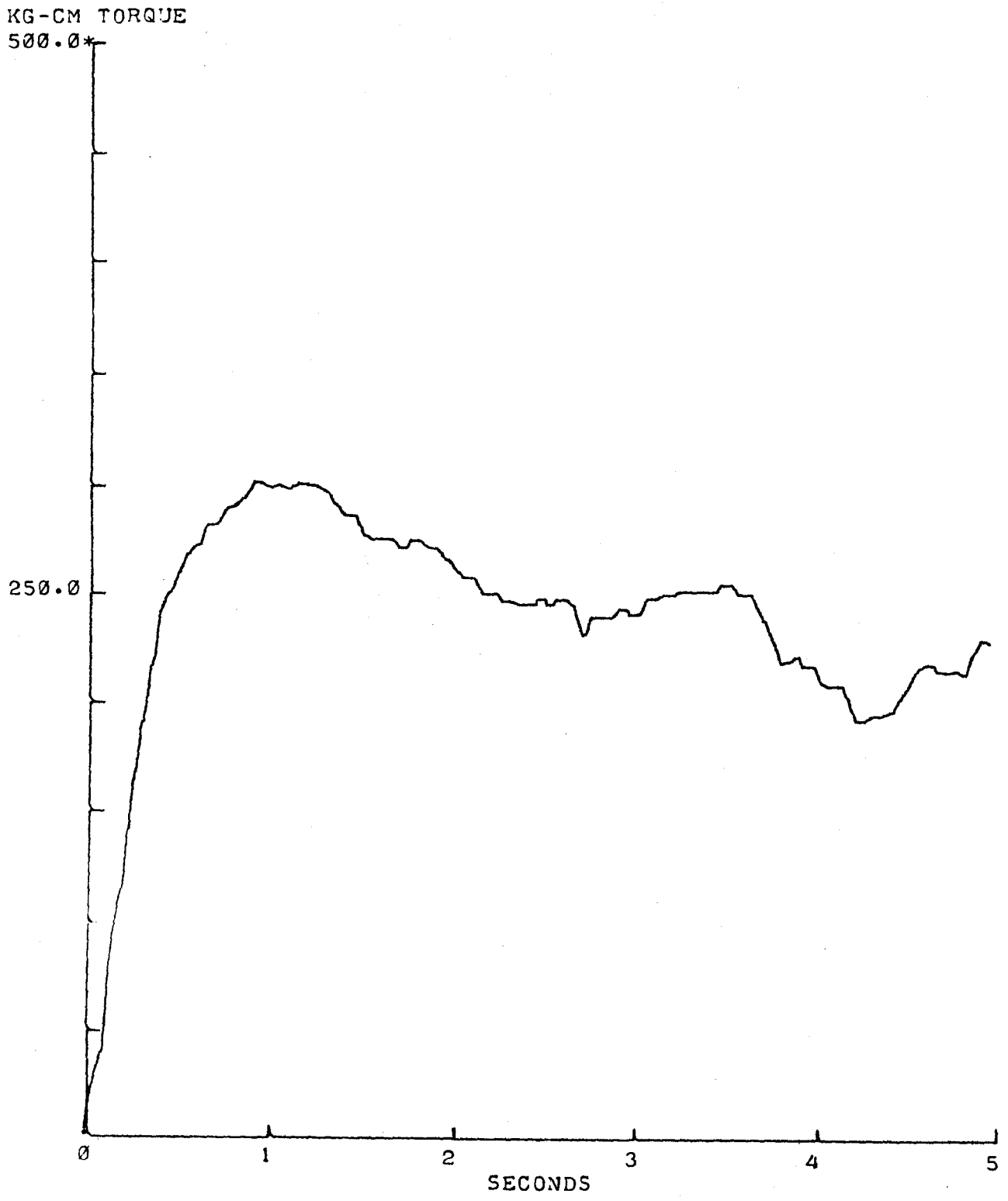

Figure 4.2.1.

*** FA0129 6/9/75 (9/6/67) 130.5 CM 27.3969 KG R HAND ***
 *** TEST 210 : ELBOW EXTENSION (90) SEQUENCE # 6 ***

CHANNEL	FUNCTION	MEAN (KG-CM)	RESTING MEAN (KG-CM)
2	(-) ELBOW EXTENSION	-158.423	-8.07928
0	(+) WRIST FLEXION	-.571037	-5.95085E-2
4	(+) SHOULDER FLEXION	-204.043	-15.6483
11	(+) HIP FLEXION	140.054	-133.309

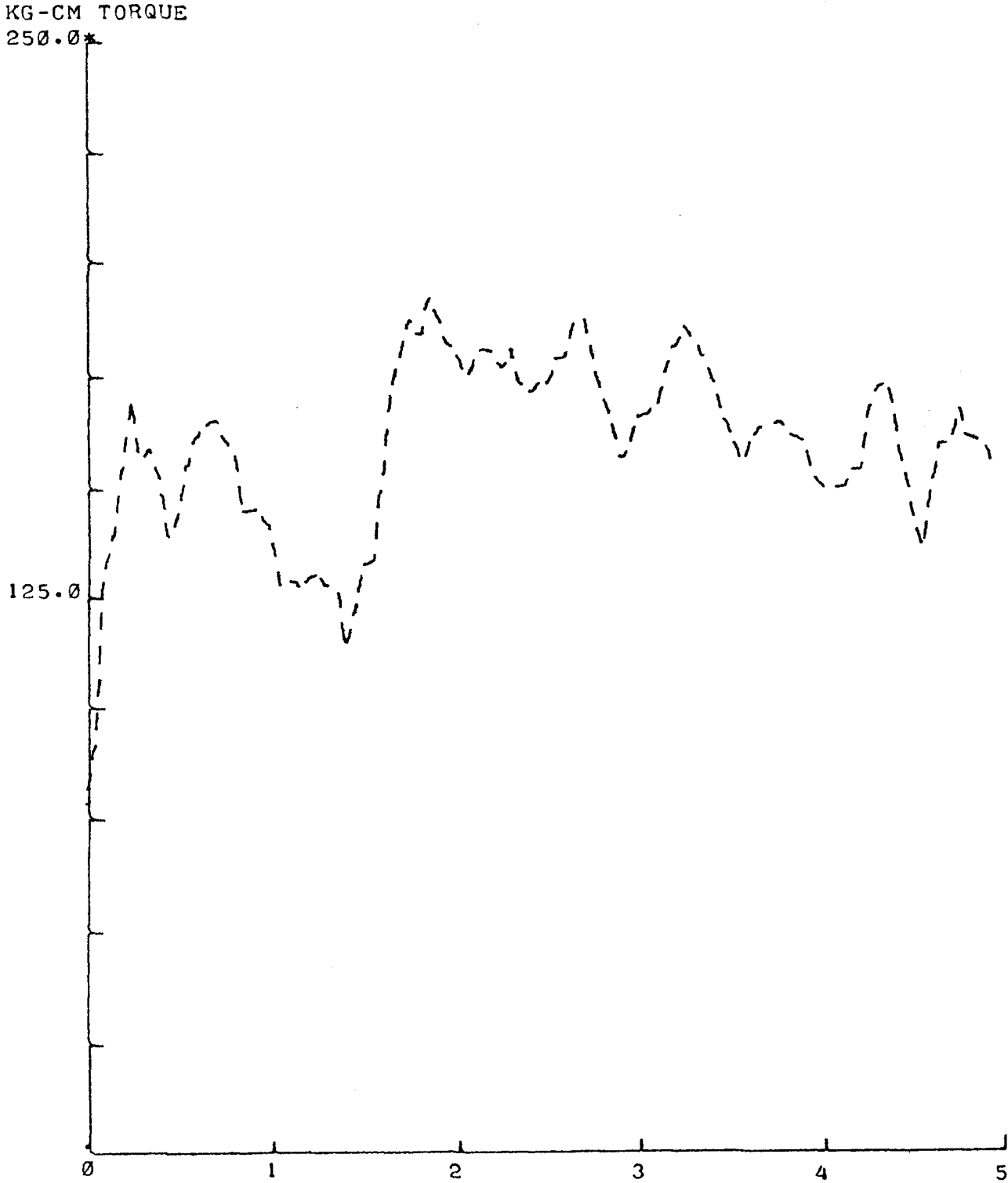

Figure 4.2.2.

*** FA0129 6/9/75 (9/6/67) 130.5 CM 27.3969 KP R HAND ***
 *** TEST 200 : ELBOW FLEXION (90) SEQUENCE # 5 ***

CHANNEL	FUNCTION	MEAN (KP-CM)	RESTING MEAN (KP-CM)
2	(+) ELBOW FLEXION	237.017	-8.07928
0	(+) WRIST ABDUCTION	2.49359	-5.95085E-2
4	(+) SHOULDER FLEXION	157.793	-15.6483
11	(+) HIP FLEXION	-517.682	-133.309

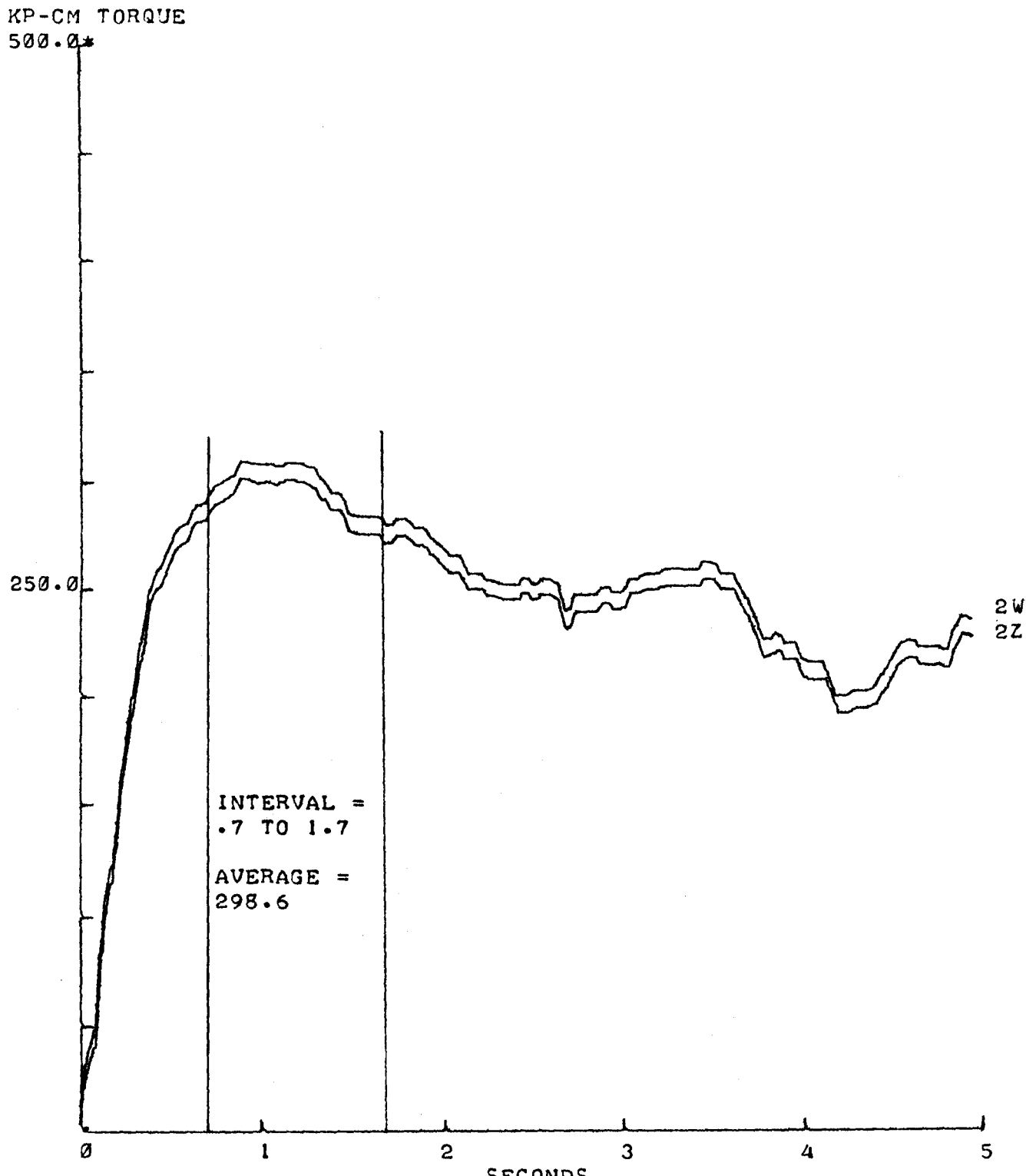

Figure 4.2.3.

CHANNEL	FUNCTION	MEAN (KP-CM)	RESTING MEAN (KP-CM)
2	(+) ELBOW FLEXION	237.017	-8.07928
0	(+) WRIST ABDUCTION	2.49359	-5.95085E-2
4	(+) SHOULDER FLEXION	157.793	-15.6483
11	(+) HIP FLEXION	-517.682	-133.309

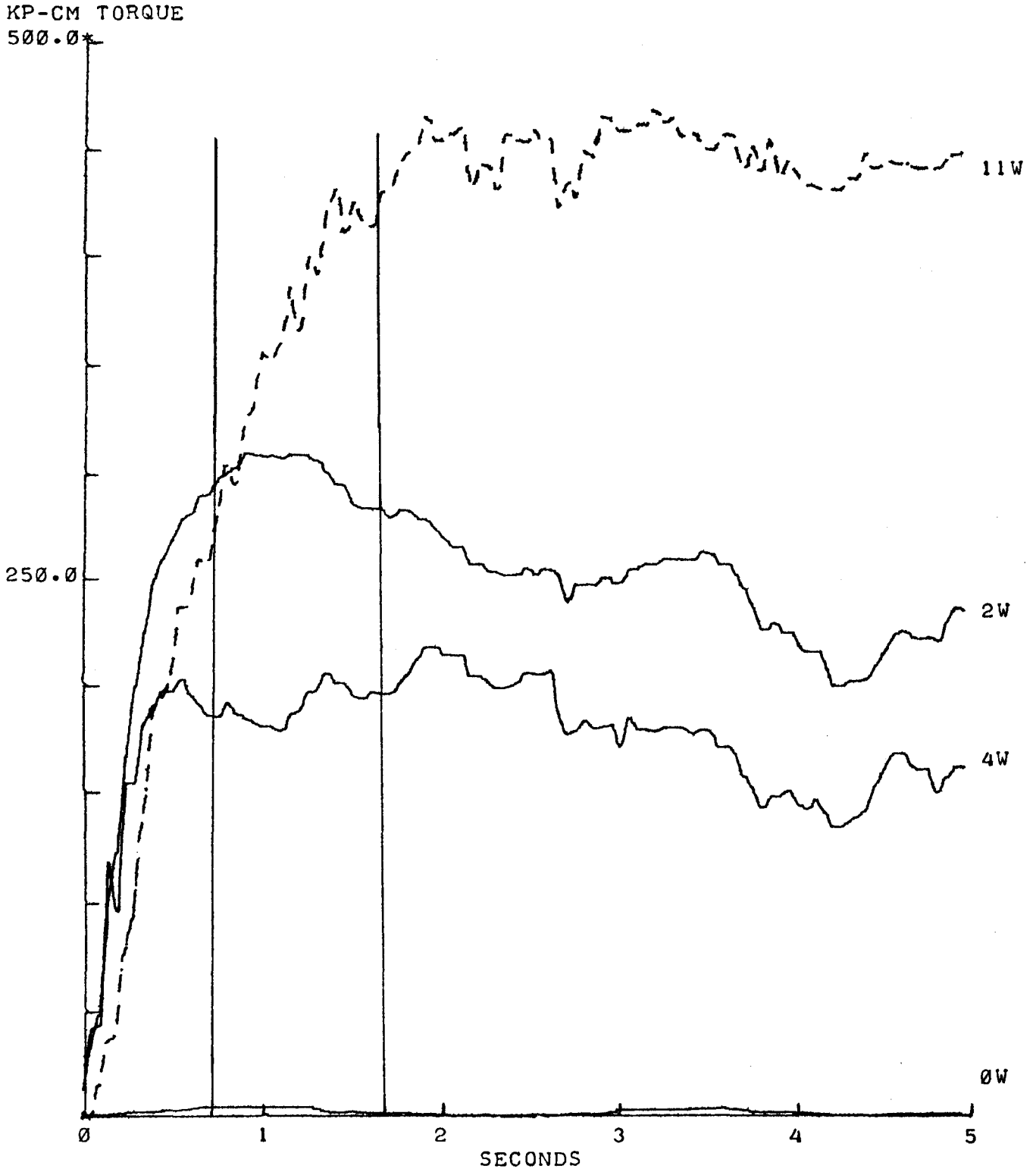

Figure 4.2.4.

4.3. Priorities

In order to gather strength data on the population of U.S. children, 502 subjects were tested. Arrangement of the thirty-three tests into priority groups was necessary in order to insure a large sample size for tests measuring strengths that frequently limit overall physical task performance (30). Accurate values for these limiting strengths are consequently very important in the biomechanical computer model (Section 6) which may be used to predict task performance. It was with this consideration that the sequence of strength tests was divided into the following three priority groups:

FIRST PRIORITY

- | | |
|-----------------------|--------------------|
| 1. Shoulder Flexion | 5. Elbow Flexion |
| 2. Shoulder Extension | 6. Elbow Extension |
| 3. Hip Flexion | 7. Knee Extension |
| 4. Hip Extension | 8. Torso Extension |

SECOND PRIORITY

- | | |
|------------------------------|-------------------------------|
| 9. Grip: Squeeze | 13. Shoulder Abduction |
| 10. Shoulder Adduction | 14. Shoulder Lateral Rotation |
| 11. Shoulder Medial Rotation | 15. Torso Flexion |
| 12. Hip Adduction | 16. Hip Abduction |

THIRD PRIORITY

- | | |
|--------------------------|---------------------------|
| 17. Knee Medial Rotation | 26. Ankle Flexion |
| 18. Grip: Lateral Pinch | 27. Wrist Supination |
| 19. Hip Medial Rotation | 28. Wrist Extension |
| 20. Wrist Pronation | 29. Wrist Abduction |
| 21. Knee Flexion | 30. Knee Lateral Rotation |
| 22. Wrist Adduction | 31. Grip: 2 Point Pinch |
| 23. Wrist Flexion | 32. Grip: 3 Point Pinch |
| 24. Ankle Extension | 33. Grip: 5 Point Pinch |
| 25. Hip Lateral Rotation | |

First priority and some second priority tests were completed in the schools while all tests were completed on subjects measured in the Strength Lab. Of the 502 subjects tested in the population survey, 115 completed only the first priority tests and 155 completed through the second priority and 232 completed all.

As has been displayed in Table I, the chair has the capability for making isometric measurements in a variety of joint angles. Figure 4.3.1. shows a child sitting in the chair in such a position. Note that the shoulder is abducted, the elbow more extended, and the knee more extended than in the standard measurement position. This represents an example of the large number of possible positions in which measurements can be obtained. For this preliminary study, however, measurements were obtained only in the standard position defined in Table I.

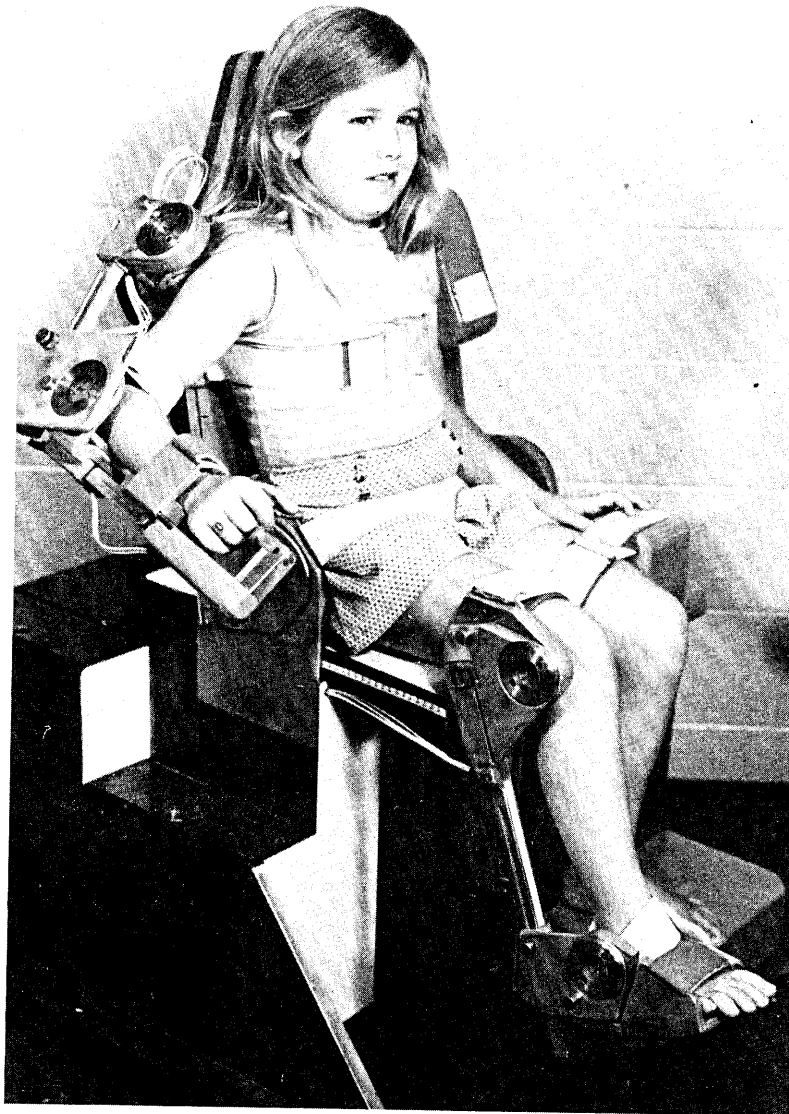

Figure 4.3.1. Child in chair adjusted to show one of many possible "non-standard" measurement positions.

4.4. ***** CHILD STRENGTH STUDY *****
 ***** REDUCED DATA FILE *****

NOTE: (+) TESTS = FLEXION, ADDUCTION, PRONATION, MEDIAL ROTATION

FILENAME	FA0129	SEX(1=M,2=F)	2
SUBJ. CODE	129	AGE (DAYS)	2830
TAPE #	35	BIRTHDATE	9/6/67
FILE TYPE	2	HAND(0,1=L,2=R)	2
#SESSIONS	1	TESTDATE (DAYS)	907

LINKAGES:

HEIGHT (CM)	130.5	LUMBAR (CM)	25
WEIGHT (KP)	27.3969	CERVICAL (CM)	16
FINGER (CM)	8.5	FEMORAL (CM)	39
CARPAL (CM)	6.5	TIBIAL (CM)	32
RADIAL (CM)	20	TARSAL (CM)	13
HUMERAL (CM)	21	CLAVICAL (CM)	21
SACRAL (CM)	10	PELVIC (CM)	19

SHOULDER FLEXION		STRENGTH	RESTING WT
TEST CODE	20	SHOULDER F/E	139.544
JT.ANGLE	0	ELBOW F/E	-189.99
UNITS	KP-CM	WRIST A/A	-3.00411
		SHOULDER A/A	-31.3918
			1.21769

SHOULDER EXTENSION		STRENGTH	RESTING WT
TEST CODE	5	SHOULDER F/E	-188.91
JT.ANGLE	0	ELBOW F/E	182.813
UNITS	KP-CM	WRIST A/A	3.1753
		SHOULDER A/A	45.0325
			1.21769

HIP FLEXION		STRENGTH	RESTING WT
TEST CODE	26	HIP F/E	407.395
JT.ANGLE	85	KNEE F/E	-26.9167
UNITS	KP-CM	ANKLE F/E	63.9073
		HIP A/A	64.2801
			-6.62414

HIP EXTENSION		STRENGTH	RESTING WT
TEST CODE	11	HIP F/E	-634.833
JT.ANGLE	85	KNEE F/E	-100.593
UNITS	KP-CM	ANKLE F/E	-119.537
		HIP A/A	-152.903
			-6.62414

ELBOW FLEXION		STRENGTH	RESTING WT
TEST CODE	18	ELBOW F/E	290.649
JT.ANGLE	90	WRIST A/A	4.17198
UNITS	KP-CM	SHOULDER F/E	174.357
		HIP F/E	-490.938
			-133.309

ELBOW EXTENSION		STRENGTH	RESTING WT
TEST CODE	3	ELBOW F/E	-179.952
JT.ANGLE	90	WRIST A/A	-.751321
UNITS	KP-CM	SHOULDER F/E	-212.021
		HIP F/E	174.209
			-133.309

KNEE EXTENSION		KNEE F/E	STRENGTH	RESTING WT
TEST CODE	9	ANKLE F/E	-512.692	11.3495
JT.ANGLE	90	HIP F/E	-352.652	-16.8934
UNITS	KP-CM	TORSO F/E	-377.701	-133.309
			-224.484	-37.921
TORSO EXTENSION		TORSO F/E	STRENGTH	RESTING WT
TEST CODE	14		-335.391	-47.6588
JT.ANGLE	0	KNEE F/E	0	0
UNITS	KP-CM	SHOULDER F/E	53.7523	22.6551
			-30.8477	-15.6483
SQUEEZE		SQUEEZE	STRENGTH	RESTING WT
TEST CODE	31	PINCH	12.1249	4.7611E-4
JT.ANGLE	2.125		0	0
UNITS	KP		0	0
			0	0
SHOULDER ADDUCTION		SHOULDER A/A	STRENGTH	RESTING WT
TEST CODE	21	SHOULDER M/L	207.633	1.29155
JT.ANGLE	5	WRIST F/E	8.41599	-.101763
UNITS	KP-CM	SHOULDER F/E	-.562762	3.84192E-2
			113.396	-15.6483
SHOULDER MEDIAL ROTATION		SHOULDER M/L	STRENGTH	RESTING WT
TEST CODE	22	WRIST F/E	222.25	-.107936
JT.ANGLE	0	ELBOW F/E	4.75731	3.84192E-2
UNITS	KP-CM	SHOULDER A/A	138.392	-7.61722
			218.598	1.21769
HIP ADDUCTION		HIP A/A	STRENGTH	RESTING WT
TEST CODE	27	HIP M/L	255.505	-6.62414
JT.ANGLE	0	KNEE M/L	39.2294	-18.4988
UNITS	KP-CM	HIP F/E	-55.6656	-2.68443
			-106.267	-133.309
SHOULDER ABDUCTION		SHOULDER A/A	STRENGTH	RESTING WT
TEST CODE	6	SHOULDER M/L	-280.678	1.29155
JT.ANGLE	5	WRIST F/E	-46.6534	-.101763
UNITS	KP-CM	SHOULDER F/E	4.7044E-3	3.84192E-2
			-74.2057	-15.6483
SHOULDER LATERAL ROTATION		SHOULDER M/L	STRENGTH	RESTING WT
TEST CODE	7	WRIST F/E	-104.313	-.107936
JT.ANGLE	0	ELBOW F/E	-1.27665	3.84192E-2
UNITS	KP-CM	SHOULDER A/A	-34.7943	-7.61722
			-257.69	1.21769
TORSO FLEXION		TORSO F/E	STRENGTH	RESTING WT
TEST CODE	29		349.264	-47.6588
JT.ANGLE	0	KNEE F/E	0	0
UNITS	KP-CM	SHOULDER F/E	-19.3722	22.6551
			32.9897	-15.6483

BIBLIOGRAPHY

- 1 ALDERMAN, R.B., AND BANFIELD, T.J.: RELIABILITY ESTIMATION IN THE MEASUREMENT OF STRENGTH. RES. QUART., 40:448, 1969.
- 2 ALEXANDER, J., AND MOLNAR, G.E.: MUSCULAR STRENGTH IN CHILDREN: PRELIMINARY REPORT ON OBJECTIVE STANDARDS. ARCH. PHYS. MED. REHABIL., 54:424, 1973.
- 3 ANDERSON, T.W.: WEIGHTED STRENGTH TESTS FOR THE PREDICTION OF ATHELETIC ABILITY IN HIGH SCHOOL GIRLS. RES. QUART., 7:136, 1936.
- 4 ARMSTRONG, T.J., AND CHAFFIN, D.B.: A BIOMECHANICAL MODEL OF THE HAND IN POWER GRIP. OCCUPATIONAL AND SAFETY ENGINEERING, UNIVERSITY OF MICHIGAN, 90 P.
- 5 AUXTER, D.M.: STRENGTH AND FLEXIBILITY OF DIFFERENTIALLY DIAGNOSED EDUCABLE MENTALLY RETARDED BOYS. RES. QUART., 37:455, 1966.
- 6 BEASLEY, W.C.: INFLUENCE OF METHOD ON ESTIMATES OF NORMAL KNEE EXTENSOR FORCE AMONG NORMAL AND POST-POLIO CHILDREN. PHYS. THER. REV., 36:21, 1956.
- 7 BECHTOL, C. O.: GRIP TESTS; USE OF DYNAMOMETER WITH ADJUSTABLE HAND SPACING. J. BONE & JOINT SURG., 36-A:820, 1954
- 8 BEDFORD, T., AND WARNER, C.G.: STRENGTH TESTS: OBSERVATIONS ON THE EFFECTS OF POSTURES ON STRENGTH OF PULL. THE LANCET, 2:1328, 1937.
- 9 BERGER, R.A.: LEG EXTENSION FORCE AT THREE DIFFERENT ANGLES. RES. QUART., 37:560, 1966.
- 10 BOOKWALTER, K.W.: GRIP STRENGTH NORMS FOR MALES. RES. QUART., 21:249, 1950.
- 11 BOWERS, L.E.: INVESTIGATION OF THE RELATIONSHIP OF HAND SIZE AND LOWER ARM GIRTHS TO HAND GRIP STRENGTH AS MEASURED BY SELECTED HAND DYNOMOMETERS. RES. QUART., 32:308, 1961.
- 12 BROWN, W.C., BUCHANAN, C.J., AND MANDEL, J.: A STUDY OF STRENGTH CAPABILITIES OF CHILDREN AGES TWO THROUGH SIX. (23 PAGES) FINAL REPORT, NBSIR 73-156, PROJECT 4460142, 1973.

- 13 BURKE, W.E.: A STUDY OF THE RELATIONSHIP OF AGE TO STRENGTH AND ENDURANCE IN GRIPPING. UNPUBLISHED DOCTORAL DISSERTATION, UNIVERSITY OF IOWA, 1952.
- 14 BURKE, W.E.: THE RELATION OF GRIP STRENGTH AND GRIP STRENGTH ENDURANCE TO AGE. J. APPL. PHYSIOL., VOL. 5, 1953.
- 15 BUXTON, D.: EXTENSION OF THE KRAUS-WEBER TEST. RES. QUART., 28:210, 1957.
- 16 CALDWELL, L.S.: BODY STABILIZATION IN THE STRENGTH OF ARM EXTENSION. J. HUMAN FACTORS, 4:125, 1962.
- 17 CALDWELL, L.S.: THE EFFECT OF FOOT-REST POSITION ON THE STRENGTH OF HORIZONTAL PULL BY THE HAND. USAMRL, REP. 423, 1960.
- 18 CALDWELL, L.S.: THE EFFECT OF THE SPATIAL POSITION OF A CONTROL ON THE STRENGTH OF SIX LINEAR HAND MOVEMENTS. USAMRL, REP. 411, 1959.
- 19 CALDWELL, L.S.: BODY POSITION AND THE STRENGTH AND ENDURANCE OF MANUAL PULL. J. HUMAN FACTORS, 4:125, 1962.
- 20 CALDWELL, L.S.: DECREMENT AND RECOVERY WITH REPETITIVE MAXIMUM MUSCULAR EXERTIONS. J. HUMAN FACTORS, 12:547, 1970.
- 21 CALDWELL, L.S.: RELATIVE MUSCLE LOADING AND ENDURANCE. J. ENGINEERING PSYCHOLOGY, 4:155, 1963.
- 22 CAMPNEY, H.K., AND WEHR, R.W.: AN INTERPRETATION OF THE STRENGTH DIFFERENCES ASSOCIATED WITH VARYING ANGLES OF PULL. RES. QUART., 36:403, 1965.
- 23 CAMPNEY, H.K., AND WEHR, R.W.: SIGNIFICANCE OF STRENGTH VARIATION THROUGH A RANGE OF JOINT MOTION. J. AMER. PHYS. THER. ASSOC., 45:773, 1965.
- 24 CARLSON, B.R., AND KROLL, W.: THE USE OF ANALYSIS OF VARIANCE IN ESTIMATING RELIABILITY OF ISOMETRIC ELBOW FLEXION STRENGTH. RES. QUART., 41:129, 1970.
- 25 CARMAN, A.: PAIN AND STRENGTH MEASUREMENTS OF 1,507 SCHOOL CHILDREN IN SAGINAW, MICHIGAN. AMER. J. PSYCHOL., 10:392, 1899.
- 26 CARPENTER, A.: A STUDY OF ANGLES IN THE MEASUREMENT OF LEG LIFT. RES. QUART., 9:70, 1938.

- 27 CARPENTER, A.: STRENGTH TESTING IN THE FIRST THREE GRADES. RES. QUART., 13:328, 1942.
- 28 CARPENTER, A.: THE MEASUREMENTS OF GENERAL MOTOR CAPACITY AND GENERAL MOTOR ABILITY IN THE FIRST THREE GRADES. RES. QUART., 13:444, 1942.
- 29 CARTER, G.H. : RECONSTRUCTION OF THE ROGERS STRENGTH AND PHYSICAL FITNESS INDICES FOR UPPER ELEMENTARY, JUNIOR HIGH AND SENIOR HIGH SCHOOL BOYS. UNPUBLISHED DOCTORAL DISSERTATION, UNIVERSITY OF OREGON, 1958.
- 30 CHAFFIN, D.B.: ERGONOMICS GUIDE FOR THE ASSESSMENT OF HUMAN STATIC STRENGTH. AMER. INDUSTRIAL HYGIENE ASSOC. JOURNAL, P. 505, 1975.
- 31 CHAFFIN, D.B., AND BAKER, W.H.: A BIOMECHANICAL MODEL FOR ANALYSIS OF SYMMETRIC SAGITTAL PLANE LIFTING. AIIE TRANSACTIONS, 2:16, 1970.
- 32 CHAFFIN, D.B.: A COMPUTERIZED BIOMECHANICAL MODEL- DEVELOPMENT OF AND USE IN STUDYING GROSS BODY ACTIONS. J. BIOMECHS., 2:429, 1969.
- 33 CHRZAN, A.E., GIBSON, G.M., AND THOMPSON, G.B.: A RE-STUDY OF THE EFFECTIVENESS OF FOUR INSTRUMENTS FOR RECORDING MUSCLE STRENGTH. UNPUBLISHED MASTER'S THESIS, SPRINGFIELD COLLEGE, 1953.
- 34 CLARKE, H., AND BAILEY, T.: STRENGTH CURVES FOR FOURTEEN JOINT MOVEMENTS. J. ASSOC. PHYS. MENT. REHAB., 4:12, 1950.
- 35 CLARKE, H.H., BAILEY, T.L., AND CLAYTON, T.S.: NEW OBJECTIVE STRENGTH TESTS OF MUSCLE GROUPS BY CABLE-TENSION METHODS. RES. QUART. 23:136, 1952.
- 36 CLARKE, H.H., ELKINS, E.C., MARTIN, G.M., AND WAKIM, K.G.: RELATIONSHIP BETWEEN BODY POSITION AND THE APPLICATION OF MUSCLE POWER TO MOVEMENTS OF THE JOINTS. ARCH. PHYS. MED., 31:81, 1950.
- 37 CLARKE, H.H.: A MANUAL: CABLE-TENSION STRENGTH TESTS. STUART E. MURPHY CO., WEST SPRINGFIELD, N.H., 1953.
- 38 CLARKE, H.H.: A RELATIONSHIP OF STRENGTH AND ANTHROPOMETRIC MEASURES TO VARIOUS ARM STRENGTH CRITERIA. RES. QUART., 25:134, 1954.

- 39 CLARKE, H.H.: COMPARISON OF INSTRUMENTS FOR RECORDING MUSCLE STRENGTH. RES. QUART., 25:398, 1954.
- 40 CLARKE, H.H.: RECENT ADVANCES IN MEASUREMENT AND UNDERSTANDING OF VOLITIONAL MUSCULAR STRENGTH. RES. QUART., 27:263, 1956.
- 41 CLARKE, H.H.: RELATIONSHIPS OF STRENGTH AND ANTHROPOMETRIC MEASURES TO PHYSICAL PERFORMANCES INVOLVING THE TRUNK AND LEGS. RES. QUART., 28:223, 1957.
- 42 CLARKE, H.H.: CORRELATION BETWEEN THE STRENGTH/MASS RATIO AND THE SPEED OF AN ARM MOVEMENT. RES. QUART., 31:570, 1960.
- 43 CLARKE, H.H. , AND CARTER, G.H.: OREGON SIMPLIFICATIONS OF THE STRENGTH AND PHYSICAL FITNESS INDICES. RES. QUART., 30:3, 1959.
- 44 CLARKE, H.H., AND JARMAN, B.O.: SCHOLASTIC ACHIEVEMENT OF BOYS 9, 12, AND 15 YEARS OF AGE AS RELATED TO VARIOUS STRENGTH AND GROWTH MEASURES. RES. QUART., 32:155, 1961.
- 45 CLARKE, H.H., AND PETERSON, K.H.: CONTRAST OF MATURATIONAL, STRUCTURAL AND STRENGTH CHARACTERISTICS OF ATHELETES AND NONATHELETES 10 TO 15 YEARS OF AGE. RES. QUART., 32:163, 1961.
- 46 CLARKE, H.H., AND CLARKE, D.H.: SOCIAL STATUS AND MENTAL HEALTH OF BOYS AS RELATED TO THEIR MATURITY, STRUCTURAL AND STRENGTH CHARACTERISTICS. RES. QUART., 32:326, 1961.
- 47 CLARKE, H.H., IRVING, R.N., AND HEATH, B.H.: RELATION OF MATURITY, STRUCTURAL AND STRENGTH MEASURES TO THE SOMATOTYPES OF BOYS 9 THROUGH 15 YEARS OF AGE. RES. QUART., 32:449, 1961.
- 48 CLARKE, H.H., AND SHELLEY, M.: MATURITY, STRUCTURE, STRENGTH, MOTOR ABILITY AND INTELLIGENCE TEST PROFILES OF OUTSTANDING ELEMENTARY AND JUNIOR HIGH SCHOOL ATHELETES. PHYSICAL EDUCATOR, 18:132, 1961.
- 49 CLARKE, H.H., AND HARRISON, J.C.: DIFFERENCES IN PHYSICAL AND MOTOR TRAITS BETWEEN BOYS OF ADVANCED, NORMAL AND RETARDED MATURITY. RES. QUART., 33:13, 1962.
- 50 CLARKE, H.H., AND WICKENS, J.S.: MATURITY, STRUCTURAL STRENGTH AND MOTOR ABILITY GROWTH CURVES OF BOYS 9-15 YEARS OF AGE. RES. QUART., 33:26, 1962.

- 51 CLARKE, H.H., AND SCHOPF, T.G.: CONSTRUCTION OF A MUSCULAR STRENGTH TEST FOR BOYS IN GRADES 4, 5, AND 6. RES. QUART., 33:515, 1962.
- 52 CLARKE, H.H., AND DEGUTIS, E.W.: RELATIONSHIPS BETWEEN STANDING BROAD JUMP AND VARIOUS MATURATIONAL, ANTHROPO-METRIC AND STRENGTH TESTS OF 12 YEAR OLD BOYS. RES. QUART. 35:258, 1964.
- 53 CLARKE, H.H.: MUSCULAR STRENGTH AND ENDURANCE IN MAN. ENGLEWOOD CLIFFS, N.J., PRENTICE-HALL, 1966.
- 54 COLGATE, J.A.: ARM STRENGTH RELATIVE TO ARM SPEED. RES. QUART., 37:14, 1966.
- 55 DANIELS, L., AND WORTHINGHAM, C.: MUSCLE TESTING; TECHNIQUES OF MANUAL EXAMINATION. SAUNDERS, 1972.
- 56 DARCUS, H.D.: A STRAIN GUAGE DYNAMOMETER FOR MEASURING THE STRENGTH OF MUSCLE CONTRACTION AND FOR RE-EDUCATING MUSCLES. ANN. PHYS. MED., 1:163, 1953.
- 57 DARCUS, H.D.: THE MAXIMUM TORQUES DEVELOPED IN PRONATION AND SUPINATION OF THE RIGHT HAND. J. ANATOMY, LONDON, VOL. 85, 1951.
- 58 DEMPSTER, W.T., SHERR, L.A., AND PRIEST, J.G.: CONVERSION SCALES FOR ESTIMATING HUMERAL AND FEMORAL LENGTHS OF FUNCTIONAL SEGMENTS IN THE LIMBS OF AMERICAN CAUCASOID MALES. HUMAN BIOLOGY, 36:246, 1964.
- 59 DEMPSTER, W.T., AND GAUGHRAN, G.: PROPERTIES OF BODY SEGMENTS BASED ON SIZE AND WEIGHT. AMER. J. ANAT., 120:33, 1967.
- 60 DICKSON, R.A., ET AL: A DEVICE FOR MEASURING THE FORCE OF THE DIGITS OF THE HAND. BIOMED. ENGIN., 7:270, 1972.
- 61 DOSS, W.S., AND KARPOVICH, P.V.: A COMPARISON OF CONCENTRIC, ECCENTRIC, AND ISOMETRIC STRENGTH OF ELBOW FLEXORS. J. APPL. PHYSIOL., 20:351, 1965.
- 62 DOWNER, A.H.: STRENGTH OF THE ELBOW FLEXOR MUSCLES. PHYS. THER. REV., 33:68, 1953.
- 63 DRURY, B.J.: MUSCLES IN ACTION. NATIONAL PRESS, 1962.

- 64 ELKINS, E.C., LEDEN, U.M., AND WAKIM, K.G.: OBJECTIVE RECORDING OF THE STRENGTH OF NORMAL MUSCLES. ARCH. PHYS. MED., 32:639, 1951.
- 65 ESPENSCHADE, A.S.: MOTOR PERFORMANCE IN ADOLESCENCE, INCLUDING THE STUDY OF RELATIONSHIPS WITH MEASURES OF PHYSICAL GROWTH AND MATURITY. MONOGRAPH SOC. RES. CHILD DEVELOP., VOL.5, NO. 1, 1950.
- 66 EVERETT, P.W., AND SILLS, F.: THE RELATIONSHIP OF GRIP STRENGTH TO STATURE, SOMATOTYPE COMPONENTS AND ANTHROPOMETRIC MEASUREMENTS OF THE HAND. RES. QUART., VOL. 23, 1952.
- 67 FISHER, M.B., AND BIRREN, J.E.: AGE AND STRENGTH. J. APPL. PSYCH., 31:490, 1947.
- 68 FLINT, M.M.: RELATIONSHIP OF THE GRAVITY LINE TEST TO POSTURE, TRUNK STRENGTH, AND HIP-TRUNK FLEXIBILITY OF ELEMENTARY SCHOOL GIRLS. RES. QUART., 35:141, 1964.
- 69 FOWLER, W.M.: QUANTITATIVE STRENGTH MEASUREMENTS IN MUSCULAR DYSTROPHY. ARCH. PHYS. MED., 48:629, 1967.
- 70 GARDNER, W.D., AND OSBURN, W.A.: STRUCTURE OF THE HUMAN BODY. SAUNDERS, 1973.
- 71 GARG, A.: THE DEVELOPMENT AND VALIDATION OF A 3-DIMENSIONAL HAND FORCE CAPABILITY MODEL. MASTER'S THESIS, UNIVERSITY OF MICHIGAN, 196 P., 1973.
- 72 GAUGHRAN, G.R., AND DEMPSTER, W.T.: FORCE ANALYSES OF HORIZONTAL TWO-HANDED PUSHES AND PULLS IN THE SAGITTAL PLANE. HUMAN BIOL., 28:67, 1956.
- 73 GEORGE, C.D.: EFFECTS OF THE ASYMMETRICAL TONIC NECK POSTURE UPON GRIP STRENGTH OF NORMAL CHILDREN. RES. QUART., 41:361, 1970.
- 74 GESER, L.R.: SKINFOLD MEASURES OF TWELVE-YEAR OLD BOYS AS RELATED TO VARIOUS MATURITY, PHYSIQUE, STRENGTH, AND MOTOR MEASURES. PH.D. IN PHYSICAL EDUCATION. 144 P., UNIVERSITY OF OREGON, 1965.
- 75 GLINES, D.: RELATIONSHIPS OF REACTION, MOVEMENT, AND COMPLETION TIMES TO CERTAIN MOTOR, STRENGTH, ANTHROPOMETRIC AND MATURITY MEASURES. UNPUBLISHED DOCTORAL DISSERTATION, UNIVERSITY OF OREGON, 1960.

- 76 GOODING, P.J.: THE EFFECTS OF TWO STRICTLY CONTROLLED MOTIVATIONAL TECHNIQUES ON THE GRIP STRENGTH OF MALE SUBJECTS. MASTER'S THESIS IN PHYSICAL EDUCATION, UNIVERSITY OF MASS., 1967.
- 77 GRIFFITTS, C.H.: THE INADEQUACY OF STRENGTH NORMS. RES. QUART., 6:117, 1935.
- 78 HAFFAJEE, D., MORITZ, U., AND SVANTESSON, G.: ISOMETRIC KNEE EXTENSION STRENGTH AS A FUNCTION OF JOINT ANGLE, MUSCLE LENGTH, AND MOTOR UNIT ACTIVITY. ACTA. ORTHOP. SCANDINAV., 43:138, 1972.
- 79 HALL, D.M.: MOTOR FITNESS TESTS FOR FARM BOYS. RES. QUART., 13:432, 1942.
- 80 HALL, D.M.: ENDURANCE TESTS FOR 4-H CLUB MEMBERS. RES. QUART., 22:37, 1951.
- 81 HALL, D.M.: SELECTION AND STANDARDIZATION OF STRENGTH TESTS FOR 4-H CLUB MEMBERS. RES. QUART., 27:285, 1956.
- 82 HARRISON, J.C.: THE CONSTRUCTION OF CABLE-TENSION STRENGTH TESTS NORMS FOR BOYS SEVEN, NINE, TWELVE, AND FIFTEEN YEARS OF AGE. M.S. IN PHYSICAL EDUCATION, UNIVERSITY OF OREGON, 1958.
- 83 HELMS, W.G.: A STUDY OF STATIC DYNAMOMETRIC STRENGTH AND ITS RELATIONSHIP TO SELECTED INDICES OF GROWTH AND DEVELOPMENT. PH.D. DISSERTATION, UNIV. OF MICHIGAN, 1961.
- 84 HENRY, F.M., AND WHITLEY, J.D.: RELATIONSHIPS BETWEEN INDIVIDUAL DIFFERENCES IN STRENGTH, SPEED, AND MASS IN AN ARM MOVEMENT. RES. QUART., 31:24, 1960.
- 85 HETTINGER, T.: PHYSIOLOGY OF STRENGTH. C.C. THOMAS, SPRINGFIELD, ILL., 1961.
- 86 HOLLINGWORTH, L.S., AND TAYLOR, G.A.: STUDIES OF PHYSICAL CONDITIONS AND GROWTH: B2. SIZE AND STRENGTH OF CHILDREN WHO TEST ABOVE 135 IQ. TWENTY-THIRD YEARBOOK OF THE NATIONAL SOCIETY FOR STUDY OF EDUCATION, PART I: THE EDUCATION OF GIFTED CHILDREN, BLOOMINGTON, ILL., PUBLIC SCHOOL PUBLISHING CO., P. 221-237, 1924.
- 87 HOUTZ, S.J., ET AL: EFFECT OF POSTURE ON STRENGTH OF THE KNEE FLEXOR AND EXTENSOR MUSCLE. J. APPL. PHYSIOL., 11:475, 1957.

- 88 HUGH-JONES, P.: THE EFFECT OF LIMB POSITION IN SEATED SUBJECTS ON THEIR ABILITY TO UTILIZE THE MAXIMUM CONTRACTILE FORCE OF THE LIMB MUSCLES. J. PHYSIOL., 105:332, 1947.
- 89 HUNSICKER, P.A.: ARM STRENGTH AT SELECTED DEGREES OF ELBOW FLEXION. AIR FORCE PROJECT NO. 7214-71727, WADC TR 54-548, WRIGHT PATTERSON AIR FORCE BASE, 1955.
- 90 HUNSICKER, P.A., AND DONNELLY, R.L.: INSTRUMENTS TO MEASURE STRENGTH. RES. QUART., 26:408, 1955.
- 91 HUNSICKER, P.A., AND GREY, G.: STUDIES IN HUMAN STRENGTH. RES. QUART., 28:109, 1957.
- 92 IKAI, M., AND STEINHOUS, A.H.: SOME FACTORS MODIFYING THE EXPRESSION OF HUMAN STRENGTH. J. APPL. PHYSIOL., 16:157, 1961.
- 93 IRISH, E.A.: OPTIMUM ENDURANCE MEASUREMENT OF ELBOW FLEXOR MUSCLES AND THE RELATIONS OF STRENGTH, ANTHROPOMETRIC, AND FATIGUE FACTORS TO ARM STRENGTH CRITERIA. UNPUBLISHED DOCTORAL DISSERTATION, UNIV. OF OREGON, 1958.
- 94 IRVING, R.N.: COMPARISON OF MATURITY, STRUCTURAL AND MUSCULAR STRENGTH MEASURES FOR FIVE SOMATOTYPE CATEGORIES OF BOYS NINE THROUGH FIFTEEN YEARS OF AGE. UNPUBLISHED DOCTORAL DISSERTATION, UNIV. OF OREGON, 1959.
- 95 JACOB, S.W., AND FRANCONI, C.A.: STRUCTURE AND FUNCTION IN MAN. SAUNDERS, 1970.
- 96 JARVIS, D.K.: RELATIVE STRENGTH OF THE HIP ROTATOR MUSCLE GROUPS. PHYS. THER. REV., 32:500, 1952.
- 97 JENSEN, C.R., AND SCHULTZ, G.W.: APPLIED KINESIOLOGY. MCGRAW-HILL, 1970.
- 98 JENSEN, R.H., SMIDT, G.L., AND JOHNSTON, R.C.: A TECHNIQUE FOR OBTAINING MEASUREMENTS OF FORCE GENERATED BY HIP MUSCLES. ARCH. PHYS. MED., 52:207, 1971.
- 99 JONES, H.E.: SKELETAL MATURITY AS RELATED TO STRENGTH. CHILD DEVELOPMENT, 17:173, 1946.
- 100 JONES, H.E.: THE SEXUAL MATURING OF GIRLS AS RELATED TO GROWTH IN STRENGTH. RES. QUART., 18:135, 1947.
- 101 JONES, H.E.: MOTOR PERFORMANCE AND GROWTH. UNIVERSITY OF CALIFORNIA PRESS, BERKELEY, CALIFORNIA, 1949.

- 102 JONES, R.E.: RELIABILITY OF MUSCLE STRENGTH TESTING UNDER VARYING MATURATIONAL CONDITIONS. J. AMER. PHYS. THER., 42:240, 1962.
- 103 KENDALL, H.O., KENDALL, F.P., AND WADSWORTH, G.E.: MUSCLES, TESTING AND FUNCTION. WILLIAMS AND WILKINS, 1971.
- 104 KENNEDY, W.R.: THE DEVELOPMENT OF AN ELECTRICAL STRAIN GAUGE DYNAMOMETER AND A CABLE TENSIO METER FOR OBJECTIVE MUSCLE TESTING. ARCH. PHYS. MED., 46:793, 1965.
- 105 KING, B.G., AND SHOWERS, M.J.: HUMAN ANATOMY AND PHYSIOLOGY. SAUNDERS, 1963.
- 106 KINTIS, P.F.: PATTERNS OF GROWTH IN STRENGTH OF ELEMENTARY SCHOOL BOYS. MASTER'S THESIS, UNIVERSITY OF WISCONSIN, 1953.
- 107 KIRCHNER, G., AND GLINES, D.: COMPARATIVE ANALYSIS OF EUGENE, OREGON ELEMENTARY SCHOOL CHILDREN USING THE KRAUS-WEBER TEST OF MINIMUM MUSCULAR FITNESS. RES. QUART., 28:16, 1957.
- 108 KIRCHNER, G.: THE CONSTRUCTION OF A BATTERY OF TESTS DESIGNED TO MEASURE STRENGTH, ENDURANCE, POWER AND SPEED AMONG ELEMENTARY SCHOOL-AGE BOYS. DOCTORAL DISSERTATION, UNIVERSITY OF OREGON, 1959.
- 109 KRAUS, H.: MINIMUM MUSCULAR FITNESS IN SCHOOL CHILDREN. RES. QUART., 25:178, 1954.
- 110 KROEMER, K.H., AND HOWARD, J.M.: PROBLEMS IN ASSESSING MUSCLE STRENGTH. AMRL-TR-68-144, WRIGHT-PATTERSON AIR FORCE BASE, OHIO, 1970.
- 111 KROEMER, K.H.: HUMAN STRENGTH TERMINOLOGY, MEASUREMENT AND INTERPRETATION OF DATA. J. HUMAN FACTORS, 12:297, 1970.
- 112 KROGMAN, W.M.: THE MANUAL AND ORAL STRENGTH OF AMERICAN WHITE AND NEGRO CHILDREN. REPORT TO THE GLASS CONTAINER MANUFACTURERS INSTITUTE, SEPTEMBER, 1971.
- 113 KROLL, W.: RELIABILITY OF A SELECTED MEASURE OF HUMAN STRENGTH. RES. QUART., 33:410, 1962.
- 114 LARSON, C.L., AND NELSON, R.C.: AN ANALYSIS OF STRENGTH, SPEED AND ACCELERATION OF ELBOW FLEXION. ARCH. PHYS. MED., 50:274, 1969.

- 115 LAUBACH, L.L.: BODY COMPOSITION IN RELATION TO MUSCLE STRENGTH AND RANGE OF JOINT MOTION. J. SPORTS. MED., 9:89, 1969.
- 116 MAGLISCHO, C.W.: BASES OF NORMS FOR CABLE-TENSION STRENGTH TESTS FOR UPPER ELEMENTARY, JUNIOR HIGH AND SENIOR HIGH SCHOOL GIRLS. RES. QUART., 39:595, 1963.
- 117 MARTIN, E.C.: MUSCLE STRENGTH AND MUSCLE SYMMETRY IN HUMAN BEINGS, I. IN CHILDREN. AMER. J. PHYSIOL., 46:67, 1918.
- 118 MARTIN, J.B., AND CHAFFIN, D.B.: BIOMECHANICAL COMPUTERIZED SIMULATION OF HUMAN STRENGTH IN SAGITTAL-PLANE ACTIVITIES. AIIE TRANSACTIONS, 4:19, 1972.
- 119 MAY, W.W.: RELATIVE ISOMETRIC FORCE OF THE HIP ABDUCTOR AND ADDUCTOR MUSCLES. PHYS. THER., 48:845, 1968.
- 120 MAYER, L., AND GREENBERG, B.B.: MEASUREMENTS OF THE STRENGTH OF THE TRUNK MUSCLES. J. BONE JOINT SURG., 24:842, 1942.
- 121 MCCLOY, C.H.: TESTS OF STRENGTH AS MEASUREMENTS OF PHYSICAL STATUS. CHAPTER VII, APPRAISING PHYSICAL STATUS, UNIVERSITY OF IOWA STUDIES IN CHILD WELFARE, 15:60, 1938.
- 122 MCCOMAS, A.J., SICA, R.E.P., AND PETITO, F.: MUSCLE STRENGTH IN BOYS OF DIFFERENT AGES. J. NEUROLOGY, NEURO-SURGERY, AND PSYCHIATRY, 36:171, 1973.
- 123 MCGRAW, L.W., AND MCCLENNEY, B.N.: RELIABILITY OF FITNESS STRENGTH TESTS. RES. QUART., 36:289, 1965.
- 124 MERCHANT, A.C.: HIP ABDUCTOR MUSCLE FORCE. J. BONE JOINT SURG. 47:462, 1965.
- 125 MEREDITH, H.: THE RHYTHM OF PHYSICAL GROWTH. A STUDY OF EIGHTEEN ANTHROPOMETRIC MEASUREMENTS IN IOWA CITY WHITE MALES RANGING IN AGE BETWEEN BIRTH AND EIGHTEEN YEARS. UNIVERSITY OF IOWA STUDIES IN CHILD WELFARE, VOL. II, NO. 3, 1935.
- 126 METHENY, E.: BREATHING CAPACITY AND GRIP STRENGTH OF PRESCHOOL CHILDREN. UNIVERSITY OF IOWA STUDIES IN CHILD WELFARE, 18:1-207, 1940.

- 127 METHENY, E.: THE PRESENT STATUS OF STRENGTH TESTING FOR CHILDREN OF ELEMENTARY SCHOOL AND PRESCHOOL AGE. RES. QUART., 12:115, 1941.
- 128 MICRO-MEASUREMENTS. ROMULUS, MICHIGAN, TECHNICAL LITERATURE.
- 129 MILLER, M.A., AND LEAVELL, L.C.: KIMBER-GRAY-STACKPOLE, ANATOMY AND PHYSIOLOGY. MACMILLAN, 1972.
- 130 MOLNAR, G.E., AND ALEXANDER, J.: OBJECTIVE MUSCLE STRENGTH IN CHILDREN: USEFULNESS OF ISOKINETIC DEVICE, SIGNIFICANCE OF PARAMETERS OF GROWTH. ARCH. PHYS. MED., 52:583, 1971.
- 131 MOLNAR, G.E., AND ALEXANDER, J.A.: OBJECTIVE, QUANTITATIVE MUSCLE TESTING IN CHILDREN: A PILOT STUDY. ARCH. PHYS. MED. REHABIL., 54:224, 1973.
- 132 MONTPETIT, R.R., MONTAYE, H.J., AND LAEDING, L.: GRIP STRENGTH OF SCHOOL CHILDREN, SAGINAW, MICHIGAN: 1899 AND 1964. RES. QUART., 38:231, 1967.
- 133 MORRIS, C.B.: THE MEASUREMENT OF THE STRENGTH OF MUSCLE RELATIVE TO A CROSS SECTION. RES. QUART., 19:295 1948.
- 134 MUNROE, R.A.: RELATIONSHIPS BETWEEN SOMATOTYPE COMPONENTS AND MATURITY, STRUCTURE, STRENGTH, MUSCULAR ENDURANCE AND MOTOR ABILITY MEASURES OF TWELVE YEAR OLD BOYS. UNPUBLISHED DOCTORAL DISSERTATION, UNIVERSITY OF OREGON, 1964.
- 135 MUNROE, R.A., CLARKE, H.H., AND HEATH, B.H.: SOMATOTYPE METHOD FOR YOUNG BOYS. AMER. J. PHYS. ANTHROP. 30:195.
- 136 MURRAY, M.P., AND SEPIC, S.B.: MAXIMUM ISOMETRIC TORQUE OF HIP ABDUCTOR AND ADDUCTOR MUSCLES. PHYS. THER., 48:1327, 1968.
- 137 NELSON, R.C., AND FAHRNEY, R.A.: RELATIONSHIP BETWEEN STRENGTH AND SPEED OF ELBOW FLEXION. RES. QUART., 36:455, 1965.
- 138 NEWMAN, L.B.: A NEW DEVICE FOR MEASURING MUSCLE STRENGTH. ARCH. PHYS. MED., 30:234, 1949.
- 139 OLSON, V.L., ET AL: THE MAXIMUM TORQUE GENERATED BY THE ECCENTRIC, ISOMETRIC AND CONCENTRIC CONTRACTIONS OF THE HIP ABDUCTOR MUSCLES. PHYS. THER., 52:149, 1972.

- 140 PAGE, J.T., AND RUBE, R.P.: FURTHER STUDIES OF THE INSTRUMENTS AND TESTS FOR MEASURING THE STRENGTH OF MUSCLES INVOLVED IN ORTHOPEDIC DISABILITIES. UNPUBLISHED MASTER'S THESIS, SPRINGFIELD COLLEGE, 1951.
- 141 PATTERSON, J.K.: THE EFFECTS OF COMPETITIVE SWIMMING TRAINING ON GIRLS IN RELATION TO THE SELECTED ANTHROPOMETRIC AND STRENGTH MEASUREMENTS. M. ED. IN PHYSICAL EDUCATION, UNIVERSITY OF TEXAS, 1965.
- 142 PROVINS, K.A.: EFFECT OF LIMB POSITION ON THE FORCES EXERTED ABOUT THE ELBOW AND SHOULDER JOINTS ON THE TWO SIDES SIMULTANEOUSLY. J. APPL. PHYSIOL., 7:387, 1955.
- 143 PROVINS, K.A.: MAXIMUM FORCES EXERTED ABOUT THE ELBOW AND SHOULDER JOINTS ON EACH SIDE SEPARATELY AND SIMULTANEOUSLY. J. APPL. PHYSIOL., 7:387, 1955.
- 144 PROVINS, K.A. AND SALTER, N.: MAXIMUM TORQUE EXERTED ABOUT THE ELBOW JOINT. J. APPL. PHYSIOL., 7:393, 1955.
- 145 QUIGLEY, B.M., AND CHAFFIN, D.B.: A COMPUTERIZED BIOMECHANICAL MODEL APPLIED TO ANALYSIS OF SKIING. MED. AND SCIENCE IN SPORTS, 3:89, 1971.
- 146 QUIGLEY, B.M.: RELATIONSHIPS AMONG ISOMETRIC MUSCULAR STRENGTH, RELATIVE-LOAD ENDURANCE, AND SELECTED CARDIOVASCULAR ELECTROMYOGRAPHIC VARIABLES. DOCTORAL DISSERTATION, UNIVERSITY OF MICHIGAN, 144 P., 1973.
- 147 RARICK, L., GROSS, K., AND MOHNS, M.J.: COMPARISON OF TWO METHODS OF MEASURING STRENGTH OF SELECTED MUSCLE GROUPS IN CHILDREN. RES. QUART., 26:74, 1955.
- 148 RARICK, L., AND THOMPSON, J.A.: ROENTGENOGRAPHIC MEASURES OF LEG MUSCLE SIZE AND ANKLE EXTENSOR STRENGTH OF SEVEN-YEAR-OLD CHILDREN. RES. QUART., 27:321, 1956.
- 149 RARICK, G.L., AND OYSTER, N.: PHYSICAL MATURITY, MUSCULAR STRENGTH AND MOTOR PERFORMANCE OF YOUNG SCHOOL-AGE BOYS. RES. QUART., 35:523, 1964.
- 150 RASCH, P.J.: RELATIONSHIP OF ARM STRENGTH, WEIGHT AND LENGTH TO SPEED OF MOVEMENT. RES. QUART., 25:328, 1954.

- 151 RASCH, P.J.: EFFECT OF POSITION OF FOREARM ON STRENGTH OF ELBOW FLEXION. RES. QUART., 27:333, 1956.
- 152 REDD, J.G.: A STUDY OF STATIC DYNAMOMETER STRENGTH IN BOYS TEN TO TWELVE YEARS OF AGE. UNPUBLISHED DOCTORAL DISSERTATION, UNIVERSITY OF MICHIGAN, 1958.
- 153 RICE, R.S., AND ROLAND, R.D.: AN EVALUATION OF THE SAFETY PERFORMANCE OF TRICYCLES AND MINIBIKES. CONTRACT NO. FDA-7291, 98 P., 1972.
- 154 RICH, G.Q.: MUSCULAR FATIGUE CURVES OF BOYS AND GIRLS. RES. QUART., 31:485, 1960.
- 155 ROBERTS, D.F., PROVINS, K.A., AND MORTON, R.J.: ARM STRENGTH AND BODY DIMENSIONS. HUMAN BIOL., 31:334, 1959.
- 156 ROHMERT, W.: THE ARM STRENGTH OF MAN STANDING IN VARIOUS BODY POSITIONS. INTERNAT. ZEIT. FUR ANGEW. PHSIOL., 18:175, 1960. (GERMAN)
- 157 ROHMERT, W.: MAXIMAL STRENGTH OF MEN IN THE MOVEMENT OF THE ARMS AND LEGS. RESEARCH REP. NO. 1616, LANDES VERLAG, 1966. (GERMAN)
- 158 ROLLO, E.T.: FACTOR ANALYSIS OF CABLE-TENSION STRENGTH TESTS FOR UPPER ELEMENTARY, JUNIOR HIGH, AND SENIOR HIGH SCHOOL GIRLS. PH.D. IN PHYSICAL EDUCATION, 108 P., UNIVERSITY OF OREGON, 1965.
- 159 SALTER, N., AND DARCUS, H.D.: THE EFFECT OF THE DEGREE OF ELBOW FLEXION ON THE MAXIMUM TORQUES DEVELOPED IN PRONATION AND SUPINATION OF THE RIGHT HAND. J. ANAT. LONDON, VOL. 86, 1952.
- 160 SCHAEFFER, J.P.: MORRIS' HUMAN ANATOMY. THE BLAKISTON CO., PHILADELPHIA, PA., 1942.
- 161 SCHANNE, F.J.: A THREE-DIMENSIONAL HAND FORCE CAPABILITY MODEL FOR A SEATED PERSON. UNPUBLISHED PH.D. DISSERTATION, UNIVERSITY OF MICHIGAN, 1972.
- 162 SCHMIDT, R.T., AND TOEWS, J.V.: GRIP STRENGTH AS MEASURED BY THE JAMAR DYNAMOMETER. ARCH. PHYS. MED., VOL. 51, NO. 6, 1970.
- 163 SCHOPF, T.G.: CONSTRUCTION OF A MUSCULAR STRENGTH TEST FOR BOYS IN GRADE FOUR, FIVE, AND SIX. UNPUBLISHED DOCTORAL DISSERTATION, UNIVERSITY OF OREGON, 1961.

- 164 SILLS, F.D., AND EVERETT, P.W.: RELATIONSHIP OF EXTREME SOMATOTYPES TO PERFORMANCE IN MOTOR AND STRENGTH TESTS. RES. QUART., 24:223, 1953.
- 165 SINGER, R.N.: PHYSICAL CHARACTERISTICS, PERPETUAL-MOTOR, AND INTELLIGENCE DIFFERENCES BETWEEN THIRD AND SIXTH GRADE CHILDREN. RES. QUART., 40:803, 1969.
- 166 SINGH, M., AND KARPOVITCH, P.V.: STRENGTH OF FOREARM FLEXORS AND EXTENSORS IN MEN AND WOMEN. J. APPL. PHYSIOL., 25:177, 1968.
- 167 SMITH, J.A.: RELATION OF CERTAIN PHYSICAL TRAITS AND ABILITIES TO MOTOR LEARNING IN ELEMENTARY SCHOOL CHILDREN. RES. QUART., 27:220, 1956.
- 168 SMITH, L.E., AND ROYCE, J.: MUSCULAR STRENGTH IN RELATION TO BODY COMPOSITION. ANN. N.Y. ACAD. SCI., 110:809, 1963.
- 169 SMITH, L.E.: SPECIFICITY OF INDIVIDUAL DIFFERENCES OF RELATIONSHIP BETWEEN FOREARM STRENGTHS AND SPEED OF FOREARM FLEXION. RES. QUART., 40:191, 1969.
- 170 SNYDER, R.G., CHAFFIN, D.B., AND SCHUTZ, R.K.: LINK SYSTEM OF THE HUMAN TORSO. FINAL REPORT, REP. NO. AMRL-TR-71-88, 273 P., ANN ARBOR, MICHIGAN, 1972.
- 171 SNYDER, R.G., SPENCER, M.L., OWINGS, C.L., AND SCHNEIDER, L.W.: PHYSICAL CHARACTERISTICS OF CHILDREN AS RELATED TO DEATH AND INJURY FOR CONSUMER PRODUCT DESIGN AND USE. FINAL REPORT, REP. NO. UM-HSRI-BI-75-5, 241 P., ANN ARBOR, MICHIGAN, 1975.
- 172 SNYDER, R.G., CHAFFIN, D.B., SCHNEIDER, .W., FOUST, D.R., BOWMAN, B.M., ABDELNOUR, T.A., AND BAUM, J.K.: BASIC BIOMECHANICAL PROPERTIES OF THE HUMAN NECK RELATED TO LATERAL HYPERFLEXION. FINAL REPORT, REP. NO. UM-HSRI-BI-75-4, 307 P., ANN ARBOR, MICHIGAN, 1975.
- 173 SNYDER, R.G., CHAFFIN, D.B., AND SCHUTZ, R.K.: LINK SYSTEM OF THE HUMAN TORSO, AMRL TECHNICAL REPORT, AMRL-TR-71-88, 1972.
- 174 STUART, H.C.: STANDARDS OF PHYSICAL DEVELOPMENT FOR REFERENCE IN CLINICAL APPRAISEMENT. J. PEDIATR., 5:194, 1934.

- 175 TANNER, J.M.: GROWTH AT ADOLESCENCE. BLACKWELL SCIENTIFIC PUBLICATIONS, 1962.
- 176 THISTLE, H.G., HISLOP, H.J., MOFFROID, M., ET AL: ISOKINETIC CONTRACTION: NEW CONCEPT OF RESISTIVE EXERCISE. ARCH. PHYS. MED. REHABIL., 48:279, 1967.
- 177 THOMPSON, C.W.: MANUAL OF STRUCTURAL KINESIOLOGY. MOSBY, 1973.
- 178 THOMPSON, C.W., AND KRANZ, L.G.: MANUAL OF STRUCTURAL KINESIOLOGY. MOSBY, 1969.
- 179 TOMARAS, W.A.: RELATIONSHIP OF ANTHROPOMETRIC AND STRENGTH MEASURES OF JUNIOR HIGH SCHOOL BOYS TO VARIOUS ARM STRENGTH CRITERIA. UNPUBLISHED DOCTORAL DISSERTATION, UNIVERSITY OF OREGON, 1959.
- 180 TOMBERLIN, J.: ISOMETRIC FORCE OF HIP ROTATOR MUSCLE GROUPS. UNPUBLISHED MASTER'S THESIS, PALO ALTO, CALIF., STANFORD UNIVERSITY, 1960.
- 181 TONER, S.B., AND BROWN, W.C.: DEVELOPMENT OF INSTRUMENTATION FOR MEASUREMENT OF THE PUSH AND PULL STRENGTHS OF PRE-SCHOOL CHILDREN. PRELIMINARY REPORT TO THE BUREAU OF PRODUCT SAFETY, FOOD AND DRUG ADMINISTRATION, MAY, 1971.
- 182 TROUP, J.D., AND CHAPMAN, A.E.: THE STRENGTH OF THE FLEXOR AND EXTENSOR MUSCLES OF THE TRUNK. J. BIOMECH., 2:49, 1969.
- 183 TUTTLE, W.W., JANNEY, C.D., AND THOMPSON, C.W.: RELATION OF MAXIMUM GRIP STRENGTH TO GRIP STRENGTH ENDURANCE. J. APPL. PHYSIOL., 2:663, 1950.
- 184 TUTTLE, W.W., JANNEY, C.D., AND SALZANO, J.V.: RELATION OF MAXIMUM BACK AND LEG STRENGTH ENDURANCE. RES. QUART., 26:96, 1955.
- 185 VAN ECK, P.J., CHAFFIN, D.B., FOUST, D.R., BAUM, J.K., AND SNYDER, R.G.: A BIBLIOGRAPHY OF WHIPLASH AND CERVICAL KINEMATIC MEASUREMENT. 164 P., UNIVERSITY OF MICHIGAN, ANN ARBOR, MICHIGAN, 1973.
- 186 WAKIM, K.G., ET AL: OBJECTIVE RECORDING OF MUSCLE STRENGTH. ARCH. PHYS. MED., 31:90, 1950.
- 187 WANG, P.Y.: GROWTH OF GRIP STRENGTH OF ZHEJIANG CHILDREN. ACTA. PSYCHOLOG. SINICA, 24:239, 1963.

- 188 WASSERMAN, D.E., GERMANN, T., GOULDING, D.V., AND PIZZO, F.:
AN INSTRUMENT FOR TESTING ISOMETRIC STRENGTH AND
ENDURANCE. NIOSH (ABSTRACT), CINCINNATI, OHIO,
MAY, 1974.
- 189 WEISS, M.W., AND FLATT, A.E.: A PILOT STUDY OF 198
NORMAL CHILDREN - PINCH STRENGTH AND HAND SIZE IN
THE GROWING HAND. AMER. J. OCCUP. THER., 25:10, 1971.
- 190 WHITE, D.E., AND LEE, G.C.: A STUDY OF THE RELATIONSHIP
OF VARIOUS STRENGTH AND ANTHROPOMETRIC MEASURES
AS RELATED TO SELECTED TRUNK AND LEG STRENGTHS
CRITERIA. UNPUBLISHED MASTER'S THESIS,
UNIVERSITY OF OREGON, 1955.
- 191 WHITLEY, J.D., AND SMITH, L.E.: VELOCITY CURVES
AND STATIC-ACTION STRENGTH CORRELATIONS IN RELATION
TO THE MASS MOVED BY THE ARM. RES. QUART., 34:379, 1963.
- 192 WHITLEY, J.D., AND SMITH, L.E.: MEASUREMENT OF
STRENGTH OF ADDUCTION OF THE ARM IN VARIOUS
POSITIONS. ARCH. PHYS. MED., 45:326, 1964.
- 193 WILLIAMS, M., AND STUTZMAN, L.: STRENGTH VARIATION
THROUGH THE RANGE OF JOINT MOTION. PHYS. THER.
REV., 39:145, 1959.
- 194 WILLIAMS, M.J., ET AL: MUSCLE FORCE CURVES OF SCHOOL
CHILDREN. J. AMER. PHYS. THER. ASSOC., 45:539, 1965.
- 195 WORDEN, C.: BASES OF NORMS FOR CABLE-TENSION STRENGTH
TESTS FOR UPPER ELEMENTARY, JUNIOR HIGH, AND
SENIOR HIGH SCHOOL GIRLS. M.ED. IN PHYSICAL
EDUCATION, UNIVERSITY OF OREGON, 1965.

NOTE: FOR USE IN THIS BIBLIOGRAPHY, JOURNAL OF THE AMERICAN
ASSOCIATION FOR HEALTH, PHYSICAL EDUCATION,
AND RECREATION IS REFERRED TO AS RESEARCH QUARTERLY
(RES. QUART.).

*

A BIOMECHANICAL COMPUTERIZED SIMULATION MODEL
OF CHILDREN'S STRENGTH

Background

Because of the increased concern of the Federal Government for product safety and health hazards [2, 13-15, 29] safe equipment design has become a major problem [1, 2, 16, 19].

The Engineering Human Performance and Safety Laboratory at the University of Michigan has been actively involved in the development of models which enable a job designer to simulate various physical tasks before committing funds for hardware and software development. Known as *biomechanical strength models*, they have been applied to ranking the stress on the musculoskeletal system during manual materials handling jobs [4]. In addition, these models have been used to predict the effects of space suits and reduced gravity on astronauts' capabilities [5], and form the basis for an employee selection system for manual materials handling activities in industry [6].

The branch of biomechanics utilizing these models involves the study of human physical attributes during infrequently occurring (less than once every 5 minutes), short duration (usually considered as less than 4 seconds) tasks [19]. These models are based on a mechanical analog of the human body. This analog treats the body segments as a set of links with masses distributed as dictated from many past population surveys. The models are implemented on a digital computer so that the designer can easily manipulate the linkage into various configurations (i.e., body postures) of interest to him.

The model described in this report predicts the maximum hand forces that a child would be able to exert safely, based on a statistically defined musculoskeletal system. The model is applicable to both a given child or a child population of interest. In other words, a job designer can specify both a specific population and a task which are of interest to him. In addition, alternative body postures can be compared by iterating the model through all feasible postures to determine which ones allow for the maximum hand forces to be produced. In the child strength model submitted with this report, child strength and size data are inputted by references which the data files described in the preceding section.

Two dimensional models have been reported in the past [7]. This paper reports the development and validation of a three dimensional biomechanical model for adults, and how it has been adapted and can be used in various design situations for children strength simulations.

Model Logic

The model logic is flowcharted in Figure 1, with the different "modes" of operation depicted in Figure 2. The following notation describes the logic used in the model:

Joints = 13 = J: (See Figure 3)
 ankle (2), knee (2), hip (2),
 lumbar (1), shoulder (2), elbow (2)
 and hand (2).

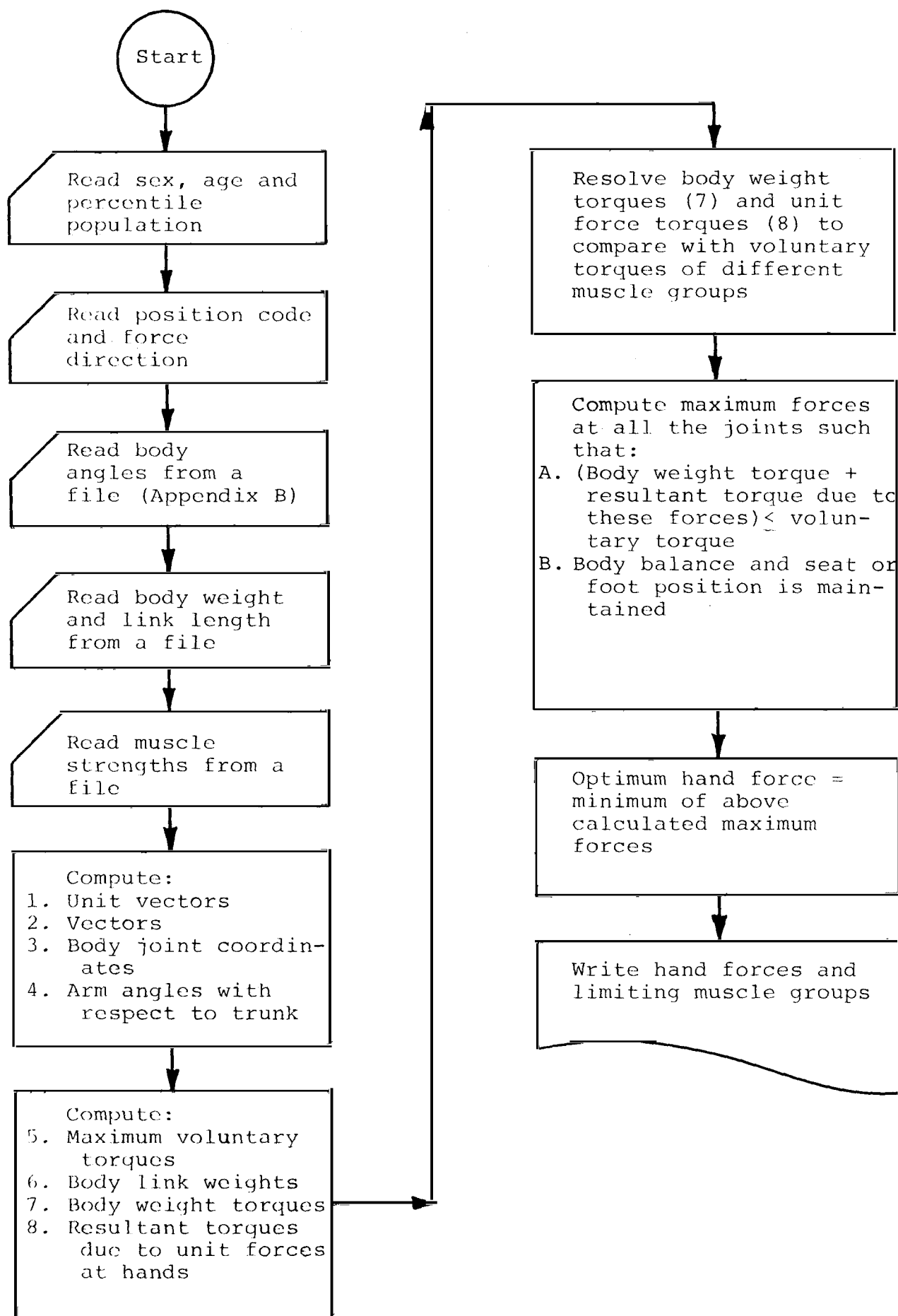
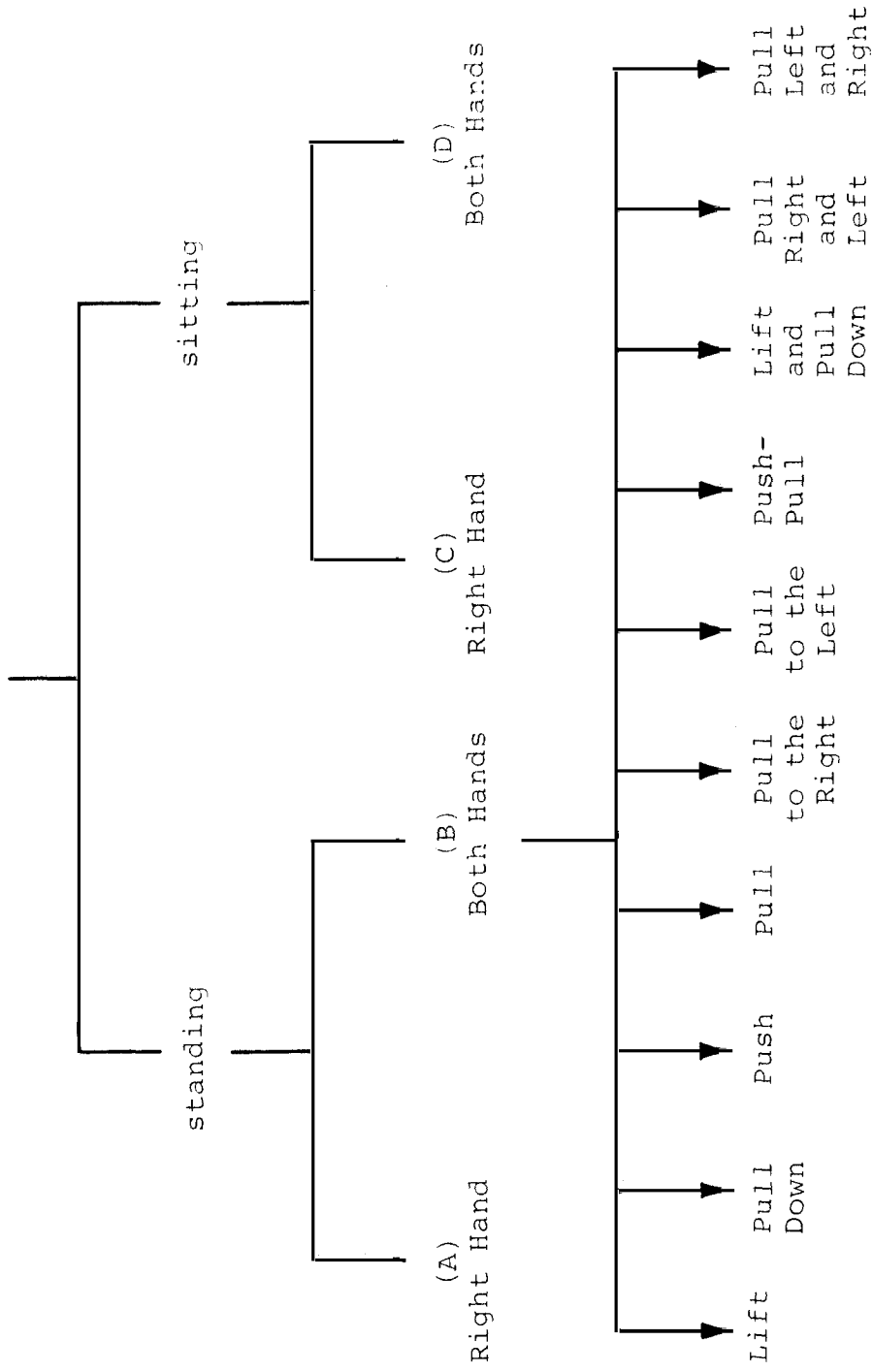

Figure 1: Macro Logic Flow Diagram



NOTE: Same number of options are available for A, C, and D.

Figure 2: Different Modes in which the Program Can Operate

- Links = 10 = K: (See Figure 3)
 ankle to knee (2), knee to hip (2),
 Hips to lumbar triangle (1), lumber to
 shoulders triangle (1), shoulder to
 elbow (2) and elbow to hand (2).
- W_{LOAD} = External load or force applied at the
 center of grip of hands (magnitude and
 direction).
- L = $[L_K]$, $K = 1, 2, \dots, 10$ = body link
 lengths. (See Figure 3.)
- W = $[W_K]$ $K = 1, 2, \dots, 10$ = body link
 weights. (See Figures 3 and 7, Table 1
 and Equation (6).
- A = $[A_{IJ}]$, $I = 1, 2, 3$; $J = 1, 2, \dots, 13$
 where A_{IJ} is the body angle at the joint
 J in the direction I and sets the
 posture (21, 27). (See Figure 4.)

Voluntary range of motion (VROM) within any reach configuration
 is given by:

$$(A_{IJ})_{\text{minimum}} \leq A_{IJ} \leq (A_{IJ})_{\text{maximum}} \quad (1)$$

where minimum and maximum values of the body angles are de-
 fined from statistical tabulations of the population's ranges
 of motion (see Figure 4 and Table 2). For further explanation,
 see references [3, 7, 21, 27].

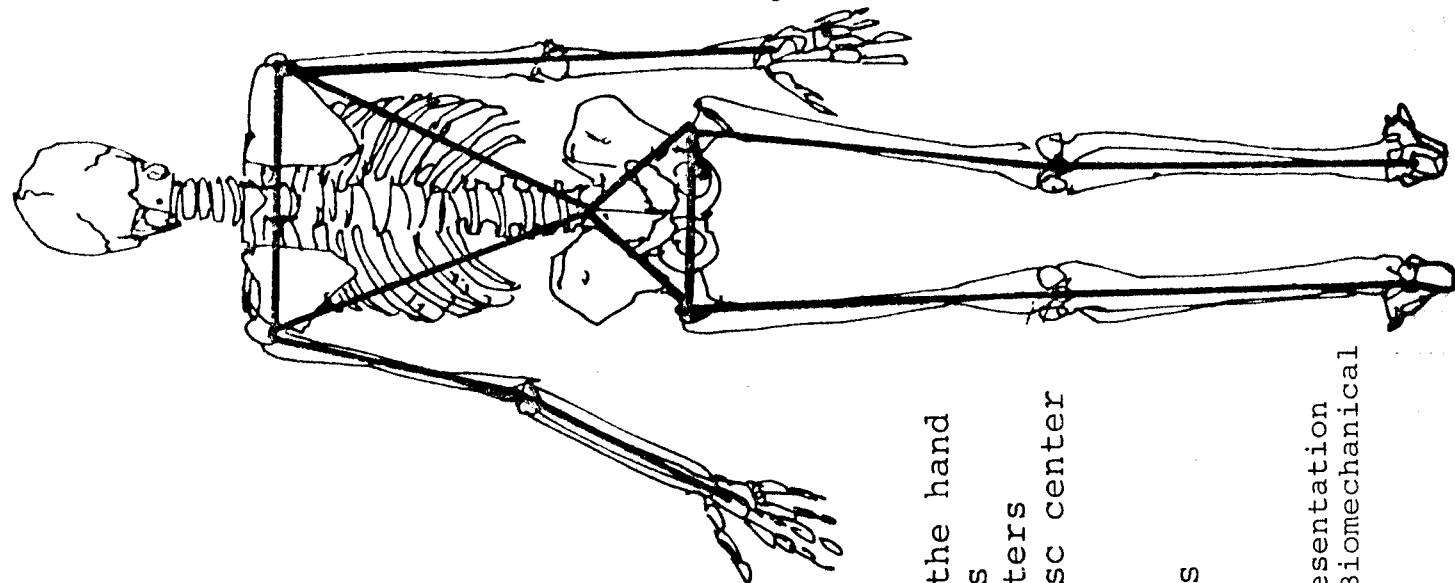
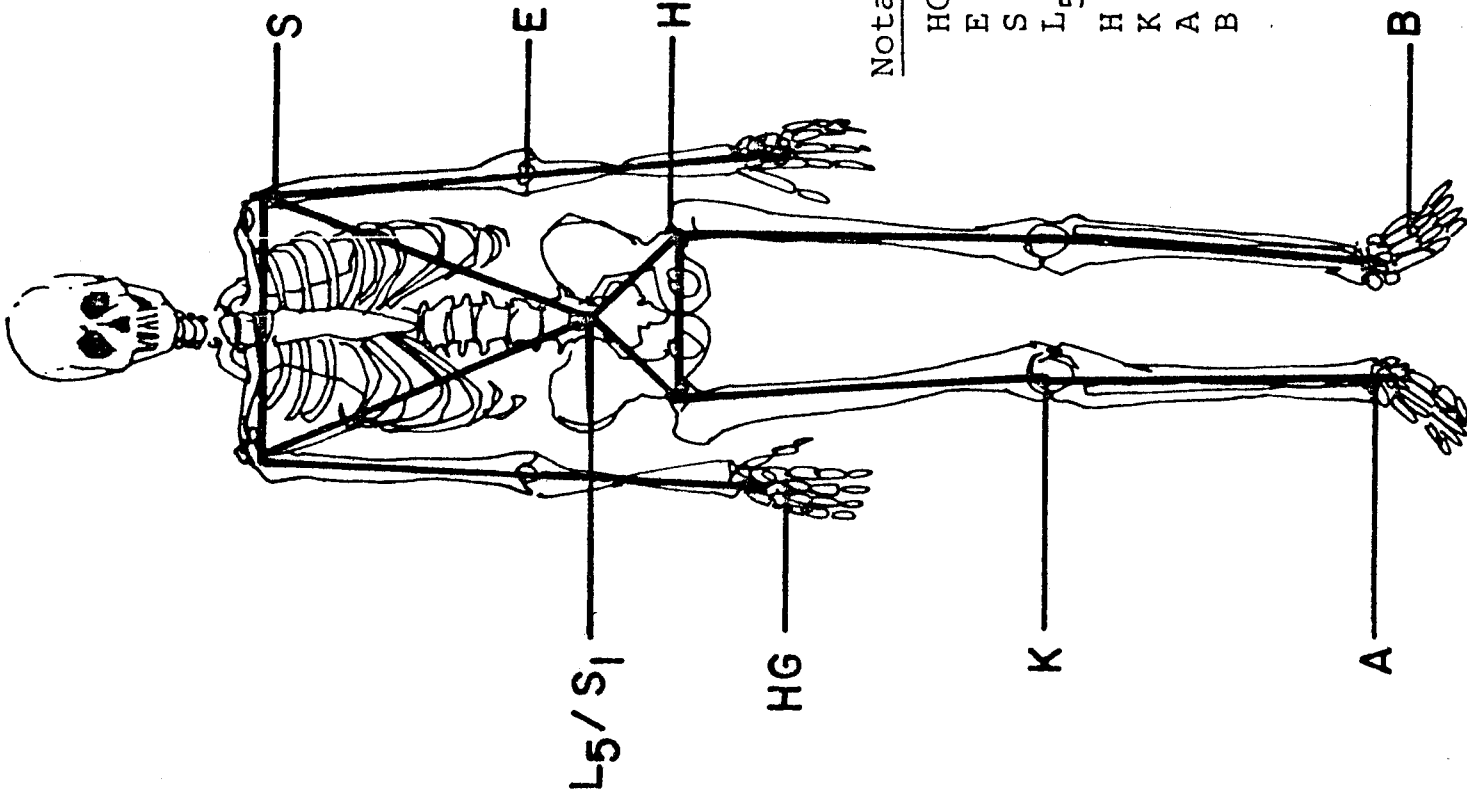

Notation:

- HG - Center of grip of the hand
- E - Elbow joint centers
- S - Shoulder joint centers
- L5 - L5/S1 vertebral disc center
- H - Hip joint centers
- K - Knee joint centers
- A - Ankle joint centers
- B - Ball of foot

Figure 3: Linkage Representation
Used in the Biomechanical
Model

Table 1

Mass of Body Links as a Proportion of
Total Body Mass (ref. 12)

Link	Link Mass (Body Mass = M)
Elbow-to-hand grip	.025M
Shoulder to elbow	.031M
Head, Neck and Trunk above L ₅ /S ₁ disc	.363M
L ₅ /S ₁ disc to Hips	.191M
Hip to Knee	.105M
Knee to Ankle	.046M
Foot*	.016M

*Foot is not considered as a link in the model.

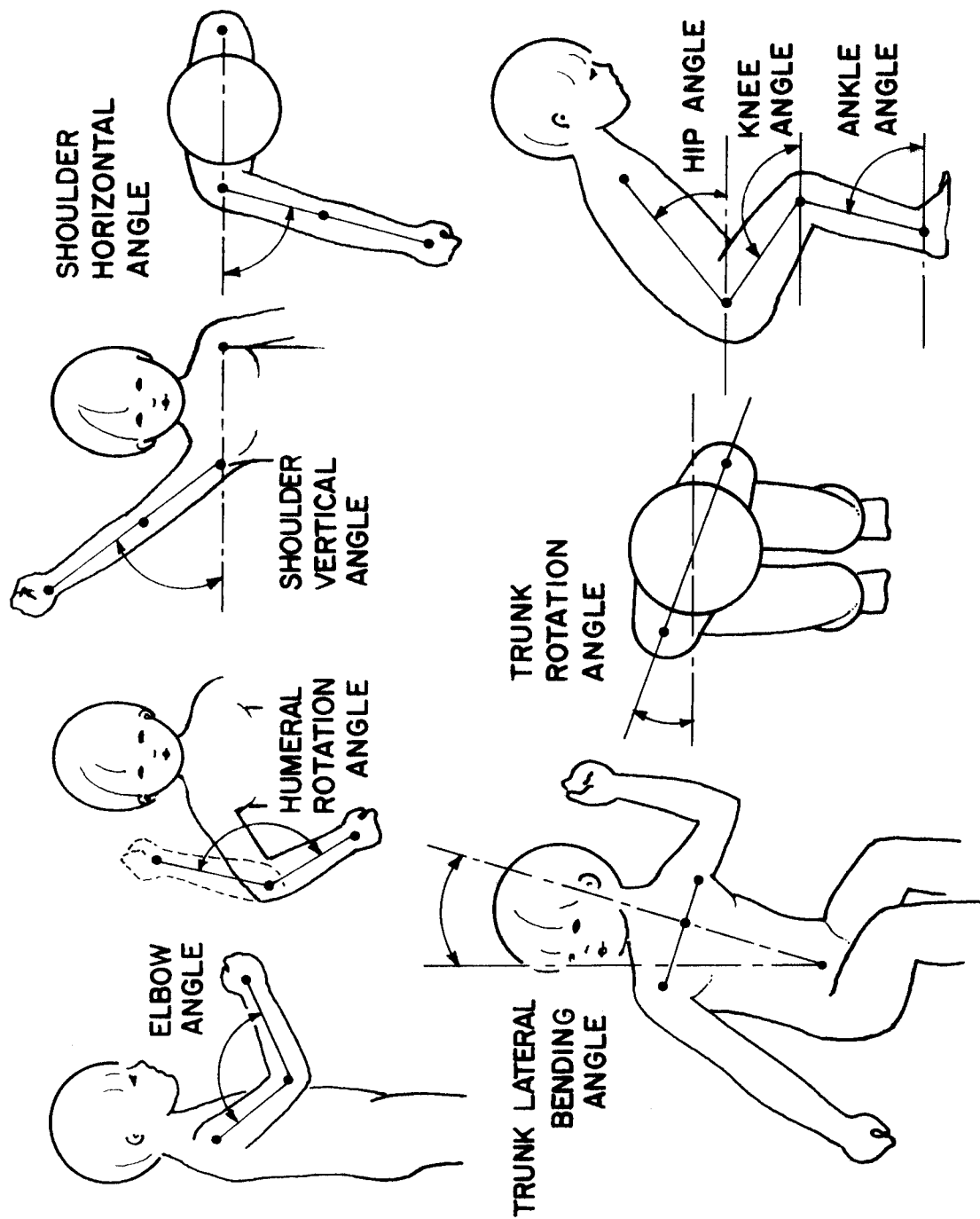

Figure 4: Body Angles Used in the Biomechanical Model

Table 2

Body Angles (A) (ref. 3, 10, 21, 27)

Joint (J)	Body Angle (A_I)	Minimum Value in Degrees	Maximum Value in Degrees
Ankle	Ankle Angle	45	90
Knee	Knee Angle	90	225
Hip	Hip Angle	-10	110
Trunk	Trunk Lateral Bending Angle	-45	45
	Trunk Rotation Angle	-45	45
Shoulder	Shoulder Vertical Angle	-90	90
	Shoulder Horizontal Angle	-45	135
	Humeral Rotation Angle	-45	135
Elbow	Elbow Angle	30	180

Resultant torques RT_{IJ} are defined as rotational moments resulting from the forces acting at the hands, body segment weights and any external constraints such as a seat back, see Equation (6). For further explanation, see references [7, 21, 27]. RT_{IJ} is a statically equivalent function of the body position (A), link lengths (L), body segment weights (W), external load at the hands (W_{LOAD}) and force due to external constraints (E). In other words:

$$RT_{IJ} = RT_{IJ}(A, L, W, W_{LOAD}, E).$$

Maximum voluntary torques VT_{IJN} represent the strength of a person for a given muscle or muscle groups. See Equations (6) and (7) and Figure 8 for an illustration of these calculations. For a further explanation, see references [7, 21, 27]. VT_{IJN} is a function of body position (A) and individual subject characteristics (C_{IJN}). Hence an individual's strengths are expressed as:

$$VT_{IJN} = C_{IJN} * VT_{IJN}(A)$$

where: N = 1 for - direction of the torques values
 = 2 for + direction of the torques values.

For the model used in this study, the positive X direction (I = 1) at the elbow is when the maximum voluntary torque for the elbow acts in flexion. And

C_{IJN} = Subject strength coefficient for muscle or muscle groups acting at joint J in the direction I and N.

For a further explanation, see Equation (7) and reference [27]. In order that the external forces acting on the body causing RT do not exceed the maximum voluntary muscle strengths VT, the following condition must be satisfied:

$$VT_{IJ1} \leq RT_{IJ} \leq VT_{IJ2} \quad (2)$$

In addition, forward and backward body balance is controlled by:

$$|RT_a| \leq \min (|W_a * L_{ah}|, |W_a * L_{ab}|) \quad (3)$$

when:

- RT_a = Resultant torque at the ankle.
- W_a = Sum of body weight and the component of W_{LOAD} acting in the direction of body weight at the ankle.
- L_{ah} = Moment arm from ankle to heel.
- L_{ab} = Moment arm from ankle to ball of foot.

For the seated operator, backward body balance is controlled by:

$$RT_h \leq d_h \times W_h \quad (4)$$

Where:

- RT_h = Resultant torque at the hip.
- W_h = Same as W_a except at the hip.
- d_h = Horizontal distance between the hip joint and backward seat contact point.

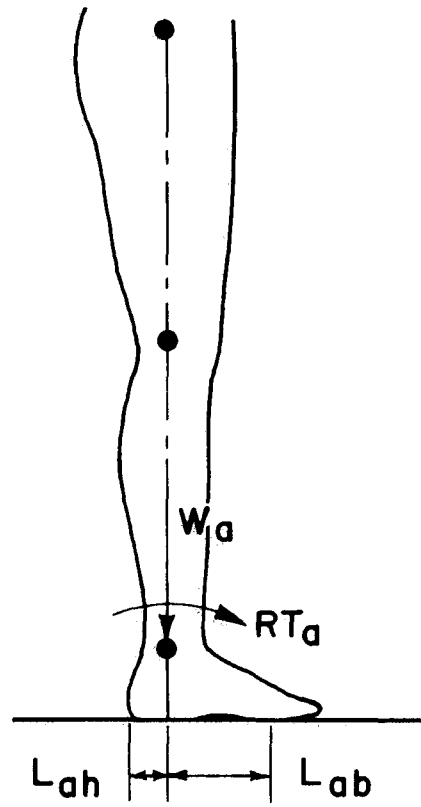

Figure 5: Body Balance

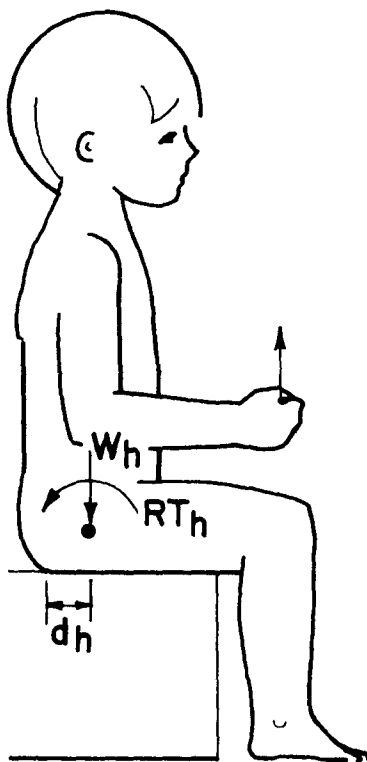

Figure 6: Backward Body Balance for a Seated Operator

Lateral body balance is controlled by:

$$[RT_{L5} + d_{L5} \times F_L] \leq [(W_{L5} + W_H) d_L/2. + (W_{UL} + W_{LL}) * d_L] \quad (5)$$

where:

- RT_{L5} = Resultant torque at the L_5/S_1 disc causing lateral tilt.
- d_{L5} = Vertical distance of L_5/S_1 disc from the floor.
- F_L = Resultant force in the lateral direction at L_5/S_1 disc.
- W_{L5} = Sum of the body weight above L_5/S_1 and the component of W_{LOAD} acting in the direction of body weight at the L_5/S_1 .
- W_H = Body weight between hips and L_5/S_1 disc.
- d_1 = Lateral distance between the two legs.
- W_{UL} = Weight of the upper leg.
- W_{LL} = Weight of the lower leg.

In addition, the following limits are applied for pull down, push and pull forward:

- A. A person cannot pull down more than one's body weight.
- B. For pulling and pushing forward, total hand forces acting in that direction should be less than or equal to coefficient of friction times the sum of body

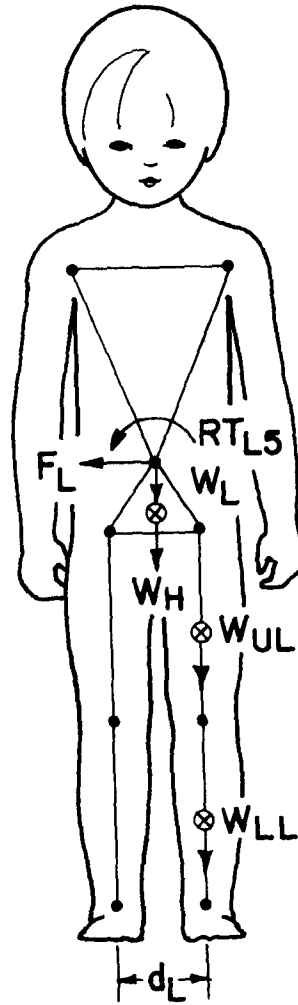

Figure 7: Lateral Body Balance

weight and the component of W_{LOAD} acting in the direction of body weight. The coefficients of friction between shoes and the floor and between the clothing and the seat are assumed to be 0.5 and 0.4 respectively.

The input required by this model are: mode of operation, subject data (sex, L, W, C_{IJN}), and task data (direction of W_{LOAD} , A). Task data are comprised of direction of forces exerted and body angles. Within the given constraints, the model simulates, (a) the feasible body positions, (i.e., a position which allows the person to reach the object to be moved) and (b) for each feasible body position it determines the maximum force capability (W_{LOAD} magnitude) that can be exerted by the hands. After simulating the feasible body position, the model predicts the maximum hand forces that the subject will be able to exert and the specific muscle group responsible for limiting these hand forces.

The maximum hand force calculated by assuming that the torque at any articulation can be represented as a linear combination of two force systems, (a) the body weights and any other external constraints, and (b) the applied forces acting at the hands. Thus, by comparing this resultant torque to the maximum voluntary torque (i.e., strength) at each articulation, the forces at the hands are obtained. The specifics of this are given later in the paper.

SUBJECT SIZE AND STRENGTH DATA

The subject size data is comprised of sex, total body weight, standing stature, wrist-to-grip center, lower arm length, upper arm length, L_5/S_1 disc to shoulder height, hips to L_5/S_1 height, upper leg length, lower leg length, ankle to ball of foot distance, shoulder width and hip width. For children, these data are statistically summarized in the preceding link length results. The mass of each link has been assumed to be proportional to total body mass (see Table 2) as indicated by the earlier mass distributions of Drillis et al. [12]. Dempster's locations of the centers-of-mass within each link have been most often quoted (see Table 3) and are employed in this model [11].

Biomechanical strength modeling involves the comparison of maximum voluntary torques (VT_{IJN}) to the torques (RT_{IJ} , called "resultant torques") resulting from the forces acting at the hands, body segment weights and any external constraints. Maximum voluntary torques representing the strength of the children are required as input data to the model, and are directly obtained from the before mentioned procedures and data summaries. A child's voluntary strength in the model (herein referred to as "reactive torques") depends upon a number of factors. The major amount these are, 1) body position, 2) individual characteristics such as health, prior training, sex, age, etc., 3) motivation, and 4) level of fatigue at the time of exertion. As discussed earlier, only by well controlled studies can meaningful strength data be gathered and used for design purposes.

Table 3

Distance From Articulations to Link Centers-of-Mass (ref. 11)

Elbow to cg of lower arm	=	.430*(Link length, elbow to wrist)
Shoulder to cg of upper arm	=	.436*(Link length, shoulder to elbow)
L ₅ /S ₁ disc to cg of trunk above L ₅ /S ₁ , neck and head	=	.4321*(Link length, L ₅ /S ₁ disc to center of shoulders)
Center of hips to cg of trunk between hips and L ₅ /S ₁ disc	=	.5*(Link length, center of hips to L ₅ /S ₁ disc)
Knee to cg of upper leg	=	.567*(Link length, knee to hip)
Ankle to cg of lower leg	=	.567*(Link length, ankle to knee)

Muscles react to an externally applied force by "pulling" across articulations. The ability of a muscle to produce a torque varies with the included angles of the joints across which it is pulling. An example is that the lower arm is stronger (i.e., has a higher maximum voluntary reactive torque) in lifting when the included angle at the elbow is 90° than when it is 180° (extended) [8, 27, 32]. Thus, by using a polynomial regression analysis of 18 (10 males and 8 females) people's elbow flexion strength at different positions, the groups' average value was estimated by one study and is expressed as follows [27]:

$$\begin{aligned} \text{VT (in-lbs)} = & 336.29 + 2.088*\alpha - 0.015*\alpha^2 \\ & - 3.364*\beta + 0.019*\beta^2 \end{aligned} \quad (6)$$

where:

- VT = Mean maximum voluntary elbow flexion reactive torque (in-lbs.)
- α = Elbow included angle (degrees)
- β = Shoulder vertical abduction angle (degrees).

This equation has adjacent angles α , β due to the flexor muscles spanning two joints. This is often the case.

To account for a child's lower strength characteristics the maximum voluntary torque predicted in Equation (4) is multiplied by a factor called the "subject strength coefficient" designated C_i and by "left-right side adjustment" designated C. An individual's elbow flexion strength is then represented as:

$$VT_i = C_i * C (336.29 + 2.088 * \alpha - 0.015 * \alpha^2 - 3.364 * \beta + 0.019 * \beta^2) / C_{AVG} \quad (7)$$

where:

C_i = subject strength coefficient.

Maximum measured strength (reactive torque) of a given muscle group for a selected body position (body angles) of i^{th} subject.

C_{AVG} = Predicted mean strength (Equation 6) of the same muscle group for the same body position over all subjects considered in population.

C = a parameter to account for the difference in right and left elbow strengths. For example, on an average for a right handed person C_1 equals 1.00 for right elbow and 0.93 for left elbow, as stated by Schanne [27]. "Left-right side adjustment" is only for arm strengths. It is assumed to be the same for all other strengths.

For example, let the selected position for determining C for elbow flexion be $\alpha = 90^\circ$ and $\beta = 0^\circ$. Let the measured elbow flexion reactive torque be equal to 623 in.-lbs. From Equation (6), $VT = 403$ in.-lbs. Therefore, $C_i = 623$ and $C_{AVG} = 403$.

Knowing C_i the subject's elbow flexion voluntary torque can be predicted for all arm positions by using Equation (7). For example, if the new position of interest is $\alpha = 135^\circ$ and $\beta = 45^\circ$ from Equation (7):

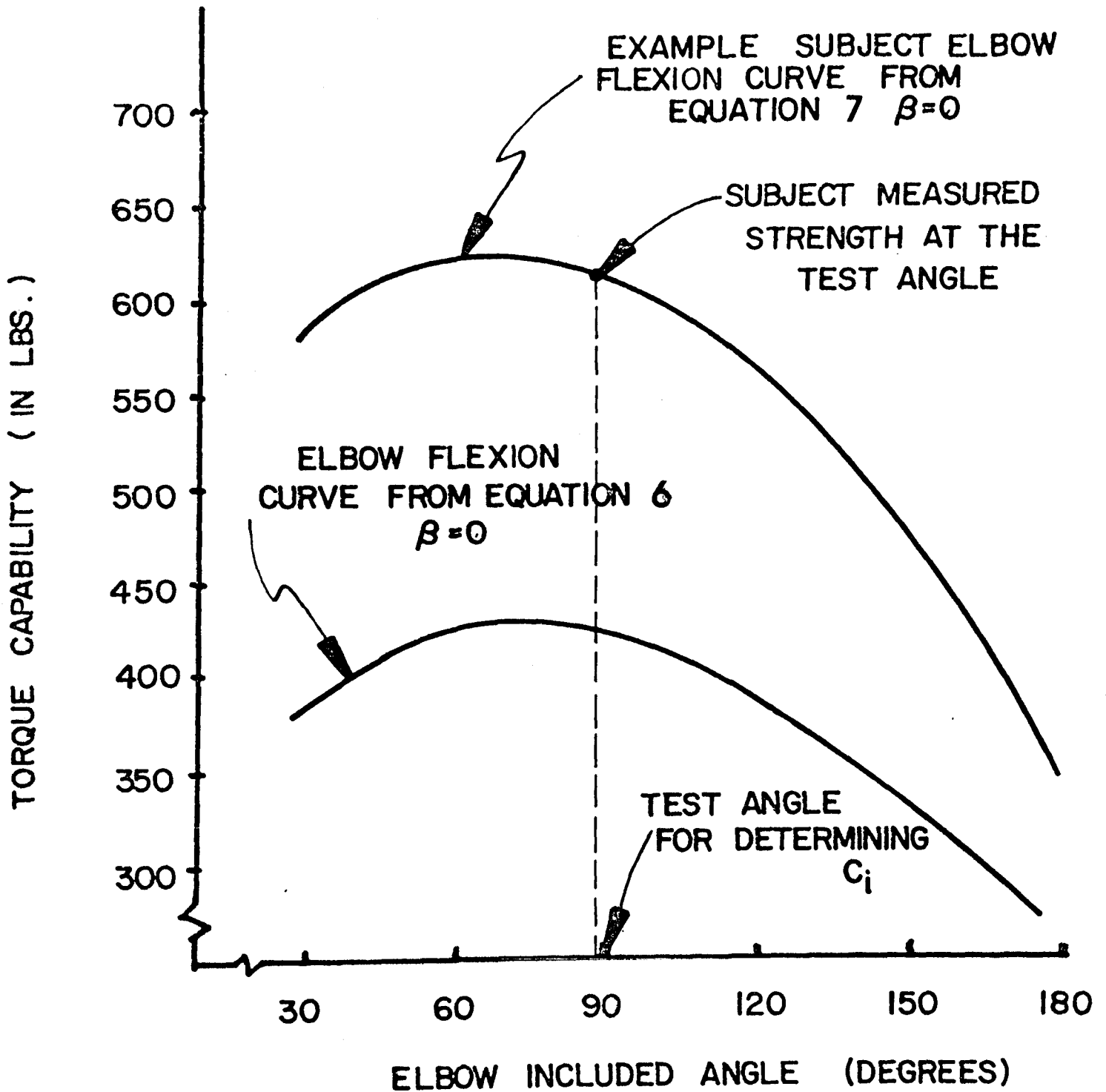

Figure 8: Example of Subject Elbow Flexion Capability and General Population Capability for Various Elbow Angles (ref. 27).

$$VT = 623 C * (336.29 + 2.088 * 135 - 0.015 * (135)^2 - 3.364 * 45 + .019 * 45^2) / 403$$

Taking C = 1 (Right handed subject and right elbow) VT = 346.977 in.-lbs. The projection technique is represented in Figure 8.

Fourteen different child strength coefficients are required in the present model to represent the different muscle groups of the arms and torso. Six additional strength coefficients are required for the hips, knees and ankles. Although voluntary torque equations involve more than one articulation angle, it is assumed that the strength of a particular muscle group is not dependent on the level of loading on adjacent articulations. There is some unpublished evidence that this is true for leg strengths.

When the model is used for a general population study, rather than for an individual, the group strength coefficients are normalized to represent various percentile populations. In this case 10, 50 and 90 percentile populations are available for both boys and girls within the age range studied.

As mentioned earlier, motivation of the subjects should be considered when interpreting the output of the model. It has been proposed in earlier work that a person instinctively limits maximum voluntary efforts when he/she "senses" possible damage to the body [6]. This limit is hypothesized to be approximately 80% of the true physiological limit, so that the model predictions for muscle strengths are considered to have a margin of safety. There is also a question regarding maximal

allowable compressive limit for the spine. For a detailed explanation see Chaffin [6]. For children such a spinal load limit is not known, so for now it must be ignored in the model until better data is available.

DETERMINATION OF BODY POSITION

Feasible positions to be analyzed are first determined by the range-of-motion. The range-of-motion of a body link is specified by two angular values, namely the minimum angle $(A_{IJ})_{\min}$ and the maximum angle. If any angle is exceeded, the model will iterate the position to find feasible angles before computing the strength limits.

Once a feasible body position is defined, the model determines the maximum force applied at the hands that the simulated subject is "capable of handling." This means that the resultant torques at each articulation due to forces at the hands, body weights, and any external constraints do not exceed the corresponding maximum voluntary reactive torques, while maintaining the body in the specified position, i.e., body balance is not lost. For the child simulations a set of 30 general postures are included for easy utilization of the model (Appendix B). Depending on the hand force directions of interest, some may be infeasible in terms of body balance.

MUSCLE STRENGTH LIMITATIONS

The resultant torques at any articulation due to forces at the hands, body weight, and external constraints are assumed to be a linear function of the magnitude of the hand force. For example, the resultant torques at the elbow and shoulder (Figure 9) would be:

$$\overline{RT}_E = EH \cdot \overline{U}_1 \cdot \overline{F} + EH \cdot \overline{U}_1 \cdot \overline{W}_1 + LA_{cg} \cdot \overline{U}_1 \cdot \overline{W}_2 \quad (8)$$

$$\overline{RT}_S = \overline{RT}_E + SE \cdot \overline{U}_2 \cdot (\overline{F} + \overline{W}_1 + \overline{W}_2) + UA_{cg} \cdot \overline{U}_2 \cdot \overline{W}_3 \quad (9)$$

where:

\overline{RT}_E	=	Resultant torque at the elbow (in.-lbs.)
\overline{RT}_S	=	Resultant torque at the shoulder (in.-lbs.)
EH	=	Link length, elbow to hand (in.)
SE	=	Link length, shoulder to elbow (in.)
LA_{cg}	=	Length, elbow to lower arm center of gravity (in.)
UA_{cg}	=	Length, shoulder to upper arm center of gravity (in.)
\overline{U}_1	=	Unit vector, elbow to hand = \overline{V}_1
\overline{U}_2	=	Unit vector, shoulder to elbow = \overline{V}_2
\overline{F}	=	Vector force at the hand (lbs.)
\overline{W}_1	=	Vector representing the weight of the hand (lbs.)
\overline{W}_2	=	Vector representing the weight of the lower arm (lbs.)
\overline{W}_3	=	Vector representing the weight of upper arm (lbs.)

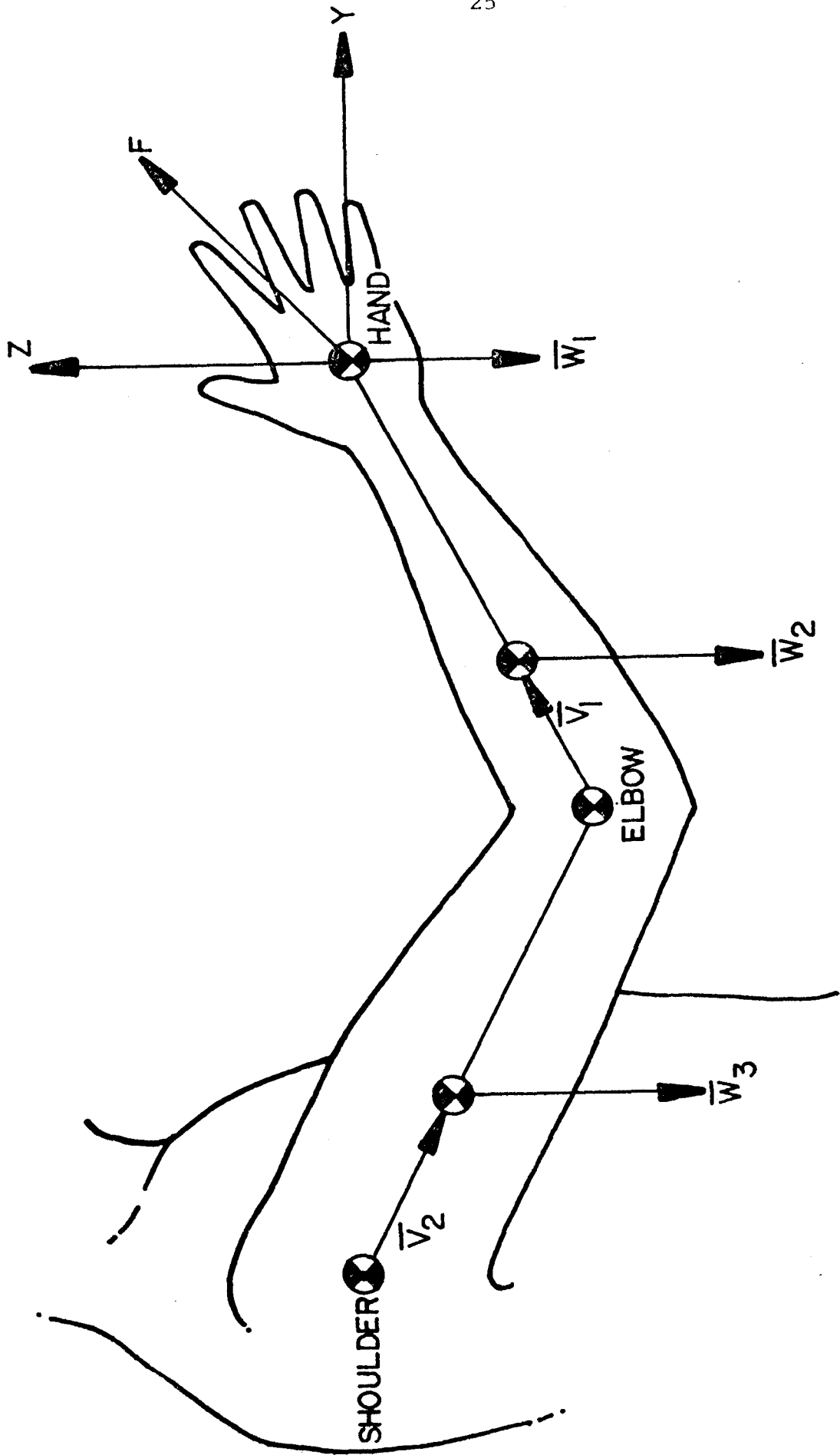

Figure 9: Determination of Resultant Torque at the Shoulder (Simplified Figure in Sagittal Plane).

X, Y, and Z coordinates of unit vectors from shoulder to elbow (\bar{U}_2) and elbow to hand (\bar{U}_1) in terms of arm angles can be represented as follows (see Figure 10):

$$\begin{aligned}
 U_{2X} &= \cos \theta \cos \beta \\
 U_{2Y} &= \sin \theta \cos \beta \\
 U_{2Z} &= \sin \beta \\
 U_{1X} &= -\cos \theta \cos \beta \cos \alpha - \cos \theta \sin \beta \cos \gamma \sin \alpha \\
 &\quad - \sin \theta \sin \gamma \sin \alpha \\
 U_{1Y} &= -\sin \theta \cos \beta \cos \alpha - \sin \theta \sin \beta \cos \gamma \sin \alpha \\
 &\quad + \cos \beta \sin \gamma \sin \alpha \\
 U_{1Z} &= -\sin \beta \cos \alpha + \cos \beta \cos \gamma \sin \alpha
 \end{aligned}$$

where:

U_{1X} , U_{1Y} and U_{1Z} are X, Y, and Z coordinates of \bar{U}_1 .

U_{2X} , U_{2Y} and U_{2Z} are X, Y, and Z coordinates of \bar{U}_2 .

Once the arm position is determined, every variable on the right side of the Equations (8) and (9) can be described in terms of arm angles, magnitude of body segment weights, and body segment lengths. The only unknown is the magnitude of hand force \bar{F} .

The resultant torque at the elbow (\overline{RT}_E) is resolved along EI''', EJ'' and EH (Figure 10); at the shoulder (\overline{RT}_S) along SE, SJ' and SK' (Figure 10) by using direction cosines resulting in (RT_E^1) and (RT_S^1) and (RT_S^1) respectively.

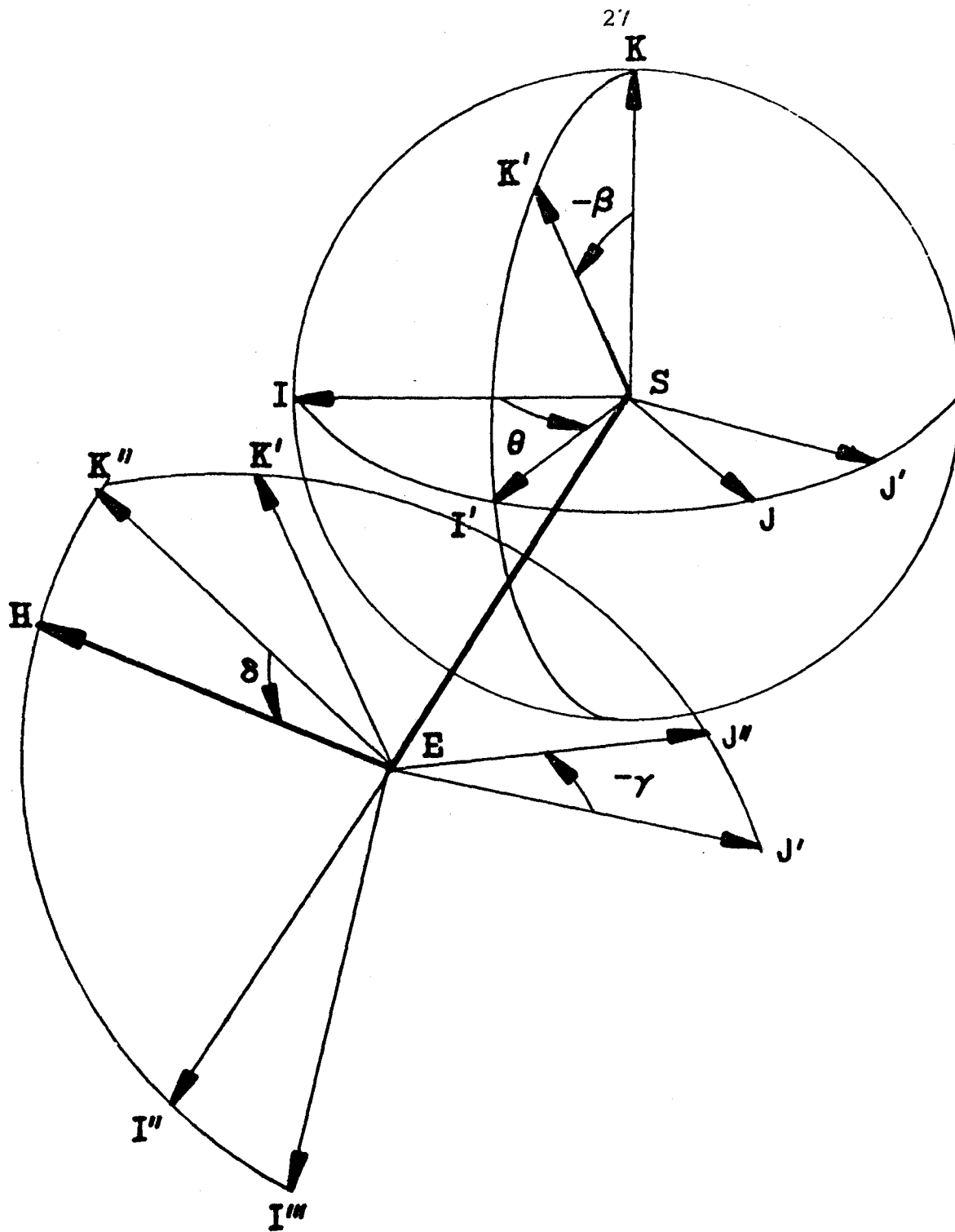

S = Shoulder

E = Elbow

H = Hand

$\angle = 90 + \delta =$ Elbow included angle

$\beta =$ Shoulder vertical angle

$\gamma =$ Humeral rotation angle

$\theta =$ Shoulder horizontal angle

Figure 10: Arm Angles Representation for Coordinate Calculations

$$\overline{RT}_E^1 = [D_E] (\overline{RT}_E)$$

$$\overline{RT}_S^1 = [D_S] (\overline{RT}_S)$$

where:

$[D_E]$ = direction cosine matrix between (EI''', EJ'', EH) and (SI, SJ, SK)

$[D_S]$ = direction cosine matrix between (SE, SJ¹, SK¹) and (SI, SJ, SK).

This gives the resultant torques as the components of interest, i.e., elbow flexion-extension at the elbow and shoulder vertical abduction-adduction, shoulder horizontal rotation forward-backward and humeral rotation medial-lateral at the shoulder. By equating each component of the resultant torque at the elbow (\overline{RT}_E^1) with its corresponding component of the voluntary reactive torque or strength (\overline{VT}), the magnitude of the hand force (\overline{F}) can be determined.

By repeating the same procedure for all the articulations, F_{ij} becomes the maximum force determined at the j^{th} articulation and for the i^{th} orthogonal force component. The minimum of all F_{ij} is the maximum force that the subject is capable of exerting safely for a defined posture.

ADULT STRENGTH MODEL VALIDATION

Model validation was performed by using previously published data on 71 male subjects from Wright-Patterson Air Force Base performing maximal exertion at 38 different positions [30].

The model validation was accomplished by comparing the model predicted hand force capabilities with those measured while the subjects pushed and pulled on a force transducer positioned in various locations. The input data available from the Air Force study was restricted to the individual's body weight, stature, magnitude of forces exerted, and a mean direction of each type of exertion by the 71 subjects. Other anthropometric dimensions required were interpolated and extrapolated using stature as the key variable, and following the proportional scaling technique used by Dempster and Graughhran (11). For example, lower arm length of a subject of 71.5 in. stature will be given by $= 10.2 + (10.9 - 10.2) * (71.5 - 70) / (73 - 70) = 10.55$ in. where 10.2 and 10.9 are lower arm lengths and 70 and 73 inches are the statures of 50 and 5% U.S. males, respectively. Thus, it was necessary to assume that stature provides a good estimate of the needed link dimensions.

Although the Air Force data were the most comprehensive available, one problem in using it for validation was the absence of specific strength coefficients for different muscle groups. Moreover, any strength data on which strength coefficients for different subjects could be determined did not exist. Since body weight was available, all fourteen different strength coefficients for the 71 subjects were determined on the basis of body weight, that is, a 180 lb. person was $180/150$ equals 1.2 times as strong as a 150 lb. person. The average correlation coefficient between

body weight and a group of selected force exertions by the subjects was 0.41. This relatively low correlation has been reported by others. It is mentioned because it is an important limitation in the validation. It means that the model was forced to treat subjects of similar body weight (resulting in similar strengths) and stature (resulting in similar link lengths) as being exactly alike, when in reality the measured force data indicates that there is significant strength variation among subjects of similar size and weight. Hence, this validation was more to determine if the model was consistent for groups of people performing various tasks rather than for groups of people performing various tasks rather than for testing the inter-subject predictability of the model.

The correlation coefficients between the measured and predicted hand forces averaged from 0.93 to 0.97, and error coefficients of variation averaged from 0.27 to 0.49. Moreover hip height predictions of strength proved to be more accurate than shoulder height predictions.

Although the predictions from the model seem to be reasonable for adults, the model has never been validated on children's strength. More strength data is needed to validate the model for children. It is, therefore, recommended that the model not be applied to body positions and force directions other than those illustrated in Appendix B. In these positions some intuitive validations have been made. Hopefully, further support can be gained to gather the data necessary to actually validate the model for children.

COMPARISON WITH TWO DIMENSIONAL STRENGTH MODEL

Although the three-dimensional strength model is much more complicated in nature than the widely used sagittal plane strength model, its strength prediction capability is comparable to or better than that of previously described two-dimensional models [21]. Figure 11 gives a graph of the predicted lifting strengths versus the measured strengths based on a two dimensional model. The best slope of the linear regression for one particular exertion, (i.e., lifting) is 0.69 with a correlation coefficient of 0.92 and a standard error of 31.8. One standardized strength and actual subject weights and statures were available to run this model and were used as input for the strength simulations shown. The three dimensional model resulted in a correlation coefficient of 0.88, a slope of 0.92 and a standard error or 39.3 on over 1045 data points. A better comparison might be to only use the lifting predictions of the two models for comparison. For lifting a simple correlation coefficient of 0.97 and a slope of 1.06 was attained over 105 data points. Figure 12 gives a graph of predicted lifting strengths versus the measured strengths based on a three-dimensional model. Actual error variation appears to be similar between the two model validation studies. This is also shown by the ratio of residual variation (σ_R) to the mean (\bar{F}_m) of measured hand force, which are 0.27 and 0.32 for the three-dimensional and the sagittal plane models respectively.

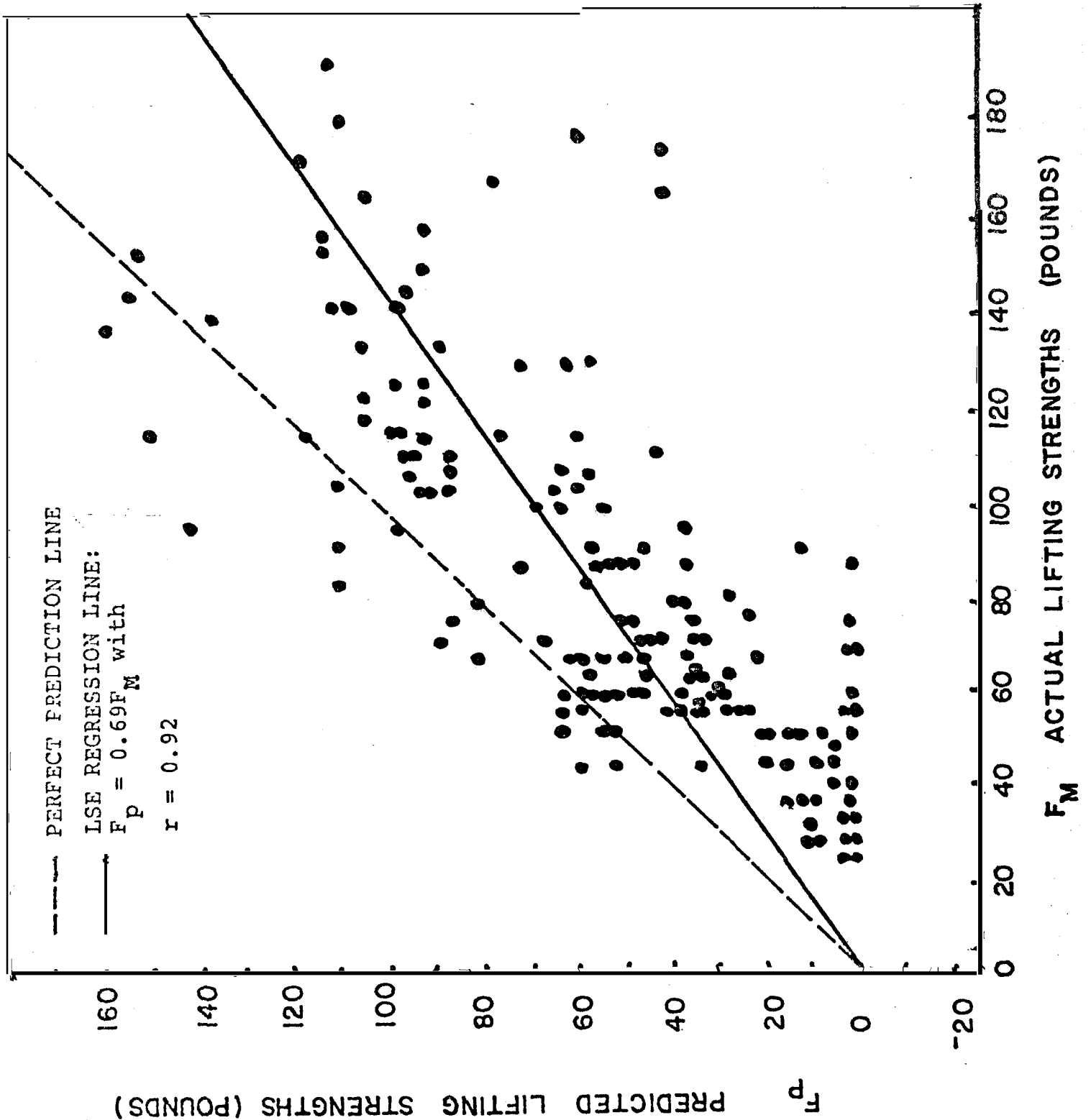

Figure 11: Graph of Actual vs. Model Predicted Hand Force Capability for Lifting Task Using Two Dimensional Model with Single Strength, Stature and Weight on Subject Input Data.

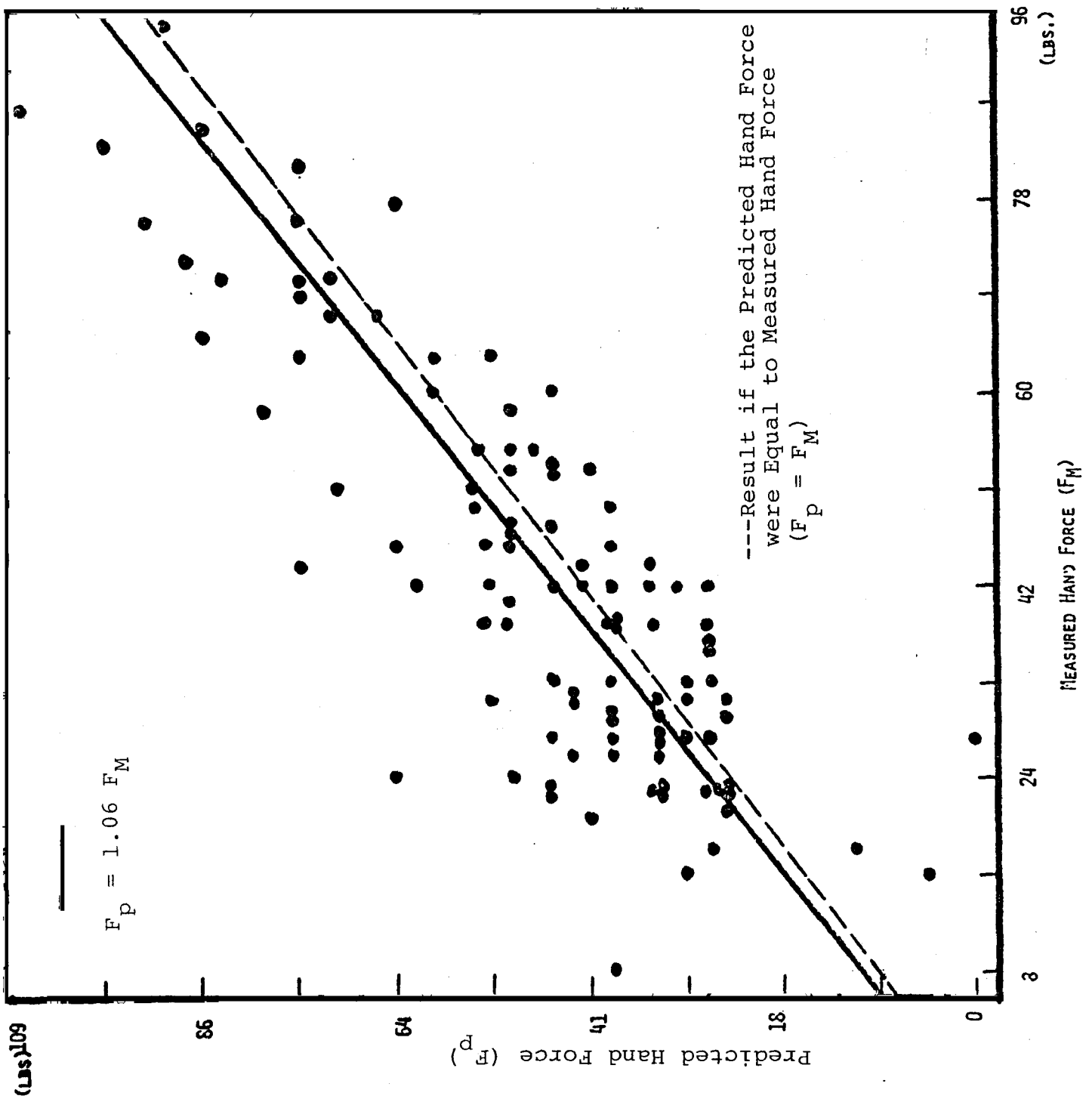

Figure 12: Graph of Predicted vs. Measured Hand Force Capability for Lifting Task Using Three-Dimensional Model.

The results of the validation study using the massive Air Force strength data, indicate that as a general rule, the model is not biased, i.e., the slope of the linear regression between the model predicted values and actually measured hand force values for over 1050 data points is very close to unity. The average standard error is 25.4 and the average coefficient of variation is 0.34. A positional analysis indicates that the model also underpredicts and overpredicts in certain tasks. These underpredictions and overpredictions are very dependent upon the direction of exertion and force location. This is possibly because of incomplete strength data over the range of motions possible at various body joints.

In spite of the gross approximation to the input data, the analysis does suggest that the model can be used to predict human strengths and particularly on a population basis. For predicting strength on an individual basis, precise information regarding strength coefficients and body segment lengths is required.

SOME PRACTICAL DATA ABOUT USE OF THE MODEL

The computer program is written in FORTRAN IV and has a storage requirement of 33,280 bytes, compared to 218,000 bytes required for the previously published sagittal plane model. The central processing unit (cpu) time required to simulate an activity depends upon the number of body positions simulated by the model to determine the optimum body position to perform the activity. On an IBM 360/70 the model requires

approximately 12 seconds of cpu time for a seated person, wherein one body position would be simulated, as has been designated for simulating a child's strength.

Although the present model evaluates only static capabilities, the model can be applied to slow, well controlled force exertions, where the effects of acceleration and momentum are negligible. Clearly to use biomechanical models to predict human strengths in highly dynamic tasks will require much more data about normal motion dynamics than presently exists in the literature. It will also require a greater understanding of the physiological basis for human motion and strength.

The computer program of the child strength model is written such that it can easily be run from a terminal. The program requires two lines of input. All the entries expected from the user are prompted by a '?' sign.

The first input line requests subject's sex, age and percentile population. All three entries should be separated by a comma. Sex can be male, female or unisex. Age can vary from 3 to 10. Population for a given age group should be either 10, 50 or 90 percentile. For example, a valid input entry would be:

Male, 7, 50

The second input line requests body position and force direction codes separated by a comma. For example:

SI-6, 2

ST-5, 1

where 'SI' and 'ST' stand for sitting and standing respectively. For valid position codes and corresponding force direction codes see Appendix B.

As an output, the program writes maximum right hand and left hand force magnitudes (in lbs.) that the child of the given sex, age and population would be able to exert in a given direction. It also prints the specific muscle group which is limiting these hand forces. If body balance is the critical factor, it is printed. A typical input and output from the computer program is given in Appendix A.

To further assist in understanding the program, a list of the program subroutines and their calling logic is presented in Appendix C. A list of program variables and definitions is given in Appendix D.

REFERENCES

- [1] Adams, S.K. Manual Materials Handling: A Position Paper, Department of Industrial Engineering, Oklahoma State University (1974).
- [2] Arthur D. Little, Inc. The Present Status and Requirements for Occupational Safety Research, Contract No. HSM-099-71-31. The National Institute for Occupational Safety and Health, U.S. Department of Health, Education and Welfare (1972).
- [3] Chaffin, D.B., Kilpatrick, K.E., Hancock, W.M. "A Computer-Assisted Manual Work Design Model," AIIE Transactions, 11(4):348-354 (1970).
- [4] Chaffin, D.B. and Park, K.S. "A Longitudinal Study of Low-Back Pain as Associated with Occupational Weight Lifting Factors," J. AIHA (Dec. 1973).
- [5] Chaffin, D.B., et al. Human Strength Simulations for One and Two-Handed Tasks in Zero Gravity, Biomechanical Division-NASA/MSD, Contract NASA-10973 (April 1972).
- [6] Chaffin, D.B. "A Person's Strength Capability as it Relates to Low-Back Pain," JOM, 16(4):248-254 (April 1974).
- [7] Chaffin, D.B. "A Computerized Biomechanical Model-- Development of and Use in Studying Gross Body Action," J. of Biomechanics, 2:429, (December 1969).
- [8] Clarke, H.H. Muscular Strength and Endurance in Man, Prentice-Hall, Inc., Englewood Cliffs, New Jersey, 39-51, (1966).
- [9] Davis, H.L., Faulkner, T.W. and Miller, C.I. "Work Physiology," Human Factors, 11(2):157-165 (1969).
- [10] Dempster, W.T. Space Requirements of the Seated Operator, WADC Technical Report 55-159, Wright Air Development Center, Wright-Patterson Air Force Base, Ohio (1955).
- [11] Dempster, W.T. and Gaughran, G.R.L. "Properties of Body Segments Based on Size and Weight," American Journal of Anatomy, 120(1967).
- [12] Drillis, R.J., Contini, R. and Bluestein, M. "Determination of Body Segment Parameters," Human Factors, 5(5):493-504, (1963).
- [13] Federal Register, Vol. 37, No. 202, Part II, Occupational Safety and Health Standards, 1910.243b(1)(ii) (October 1972).

- [14] Glover, J.R. "Occupational Health Research and the Problem of Back Pain," Transactions of the Society of Occupational Medicine, 21:2-12 (1971).
- [15] "Human Kinetics and Lifting." National Safety News, 6:44-47 (1971).
- [16] Ingenohl, I. "Measuring Physical Effort," Journal of Industrial Engineering, 10(2):99-144 (1959).
- [17] Kilpatrick, K. "A Biokinematic Model for Workplace Design," Human Factors, 14(3):237-247 (1972).
- [18] Kottke, F. "Evaluation and Treatment of Low-back Pain Due to Mechanical Causes," Archives of Physical Medicine, 42:426-440 (1961).
- [19] Kroemer, K.H.E. "Human Strength: Terminology, Measurement, and Interpretation of Data," Human Factors, 12(3):297-313 (1970).
- [20] Leavitt, S.S., Johnson, T.L., Beyer, R.D. "The Process of Recovery: Patterns in Industrial Back Injury, Part I: Costs and Other Quantitative Measures of Effort," Industrial Medicine and Surgery, 49(8):7-14 (1971).
- [21] Martin, J.B. and Chaffin, D.B. "A Biomechanical Computerized Simulation of Human Strength in Sagittal Plane Activities," AIIE Transactions, 4:1, (March 1972).
- [22] McGill, C. "Industrial Back Problems--A Control Program," Journal of Occupational Medicine, 10(4):174-178 (1968).
- [23] Nachemson, A. "The Load on Lumbar Discs in Different Position of the Body," Clinical Orthopedics, 45:107-122 (1966).
- [24] "Potential of Biomechanicals for Solving Specific Hazard Problems," Proceedings Professional Conference, American Society of Safety Engineers, 149-187, Park Ridge, Ill. (1968).
- [25] Rosse, C. and Clawson, D.K. Introduction to the Musculoskeletal System, Harpers and Row Publishers, New York (1970).
- [26] Rowe, M.L. "Lowback Pain in Industry: A Position Paper," Journal of Occupational Medicine, 11(4):161-169 (1969).

- [27] Schanne, F. A Three-Dimensional Hand Force Capability Model for the Seated Operator, Ph.D. Thesis, the University of Michigan, University Microfilms, Inc., Ann Arbor, Michigan (1972).
- [28] Snyder, R.G., Chaffin, D.B. and Schutz, R.K. Link System of the Human Torso, AMRL Technical Report, AMRL-TR-71-88 (1972).
- [29] Teach Them to Lift, Safety in Industry Series, Bulletin 110, Wage and Labor Standards Administration, Bureau of Labor Standards, U.S. Department of Labor (1970).
- [30] Thordsen, M.L., Kroemer, K.H.E. and Laubach, L.L. Human Force Exertions in Aircraft Control Locations, Aerospace Medical Research Laboratory, Wright-Patterson Air Force Base, Ohio (February 1972).
- [31] Tichauer, E.R. "A Pilot Study of the Biomechanics of Lifting in Simulated Industrial Work Situations," Journal of Safety Research, 3(3):98-115 (1971).
- [32] Williams, M. and Stutzman, L. "Strength Variations Through the Range of Joint Movements," The Physical Therapy Review, 37(2) (1959).

APPENDIX A

TYPICAL OUTPUT FROM THE MODEL

PROGRAM FOR
 BIOMECHANICAL ANALYSIS OF THREE DIMENSIONAL STRENGTH
 HUMAN PERFORMANCE GROUP
 UNIVERSITY OF MICHIGAN

ENTER SEX(MALE,FEMALE OR UNISEX), AGE(3-9) AND
 PERCENTILE(10,50,90). FOR EXAMPLE,MALE,7,50

?MALE 7 #

?MALE,7,50

ENTER POSITION NO. AND FORCE DIRECTION CODE
 FOR EX. SI-10,3

?SI-7,5

* RIGHT HAND FORCE(LBS.)

24

LEFT HAND FORCE(LBS.)

23

*LIMIT DUE TO

LEFT SHOULDER VERTICAL ADDUCTION

RIGHT SHOULDER VERTICAL ADDUCTION

* RIGHT HAND FORCE(LBS.)

13

LEFT HAND FORCE(LBS.)

12

*LIMIT DUE TO

FORWARD BODY BALANCE LOST

DO YOU WISH TO CONTINUE? TYPE YES OR NO.

?YES

ENTER SEX(MALE,FEMALE OR UNISEX), AGE(3-9) AND
 PERCENTILE(10,50,90). FOR EXAMPLE,MALE,7,50

?UNISEX,7,10

ENTER POSITION NO. AND FORCE DIRECTION CODE
 FOR EX. SI-10,3

?SI-7,5

* RIGHT HAND FORCE(LBS.)

13

LEFT HAND FORCE(LBS.)

12

*LIMIT DUE TO

LEFT SHOULDER VERTICAL ADDUCTION

RIGHT SHOULDER VERTICAL ADDUCTION

* RIGHT HAND FORCE(LBS.)

11

LEFT HAND FORCE(LBS.)

10

*LIMIT DUE TO

FORWARD BODY BALANCE LOST

DO YOU WISH TO CONTINUE? TYPE YES OR NO.

?YES

APPENDIX B

STANDARD POSTURES AND FORCE DIRECTION CODES

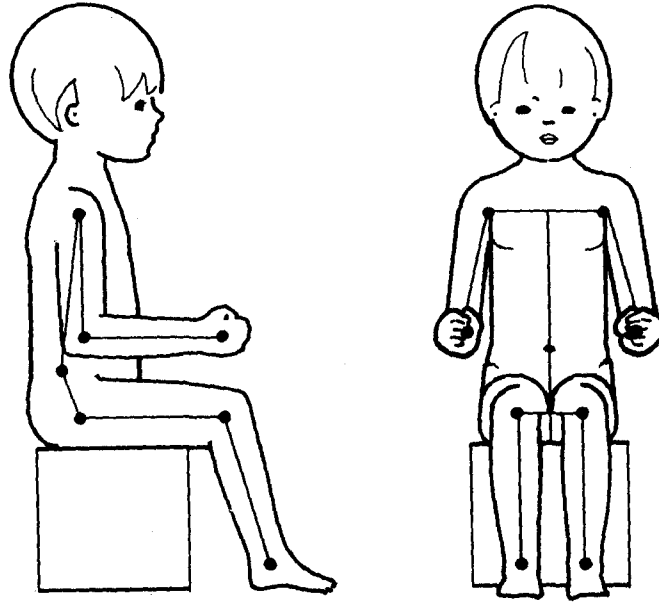

SI-1

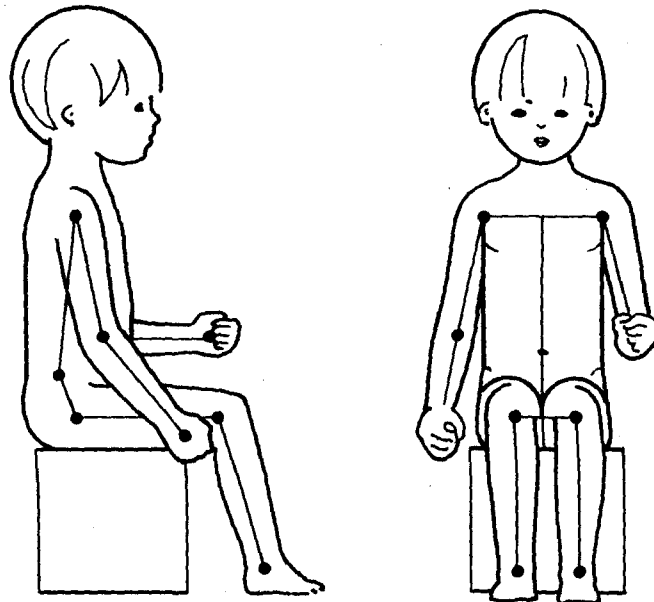

SI-2

B-2

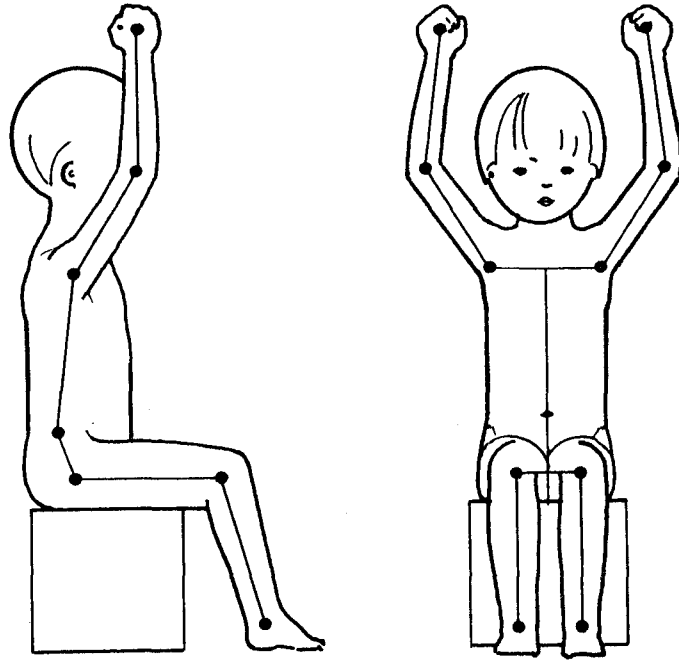

SI-3

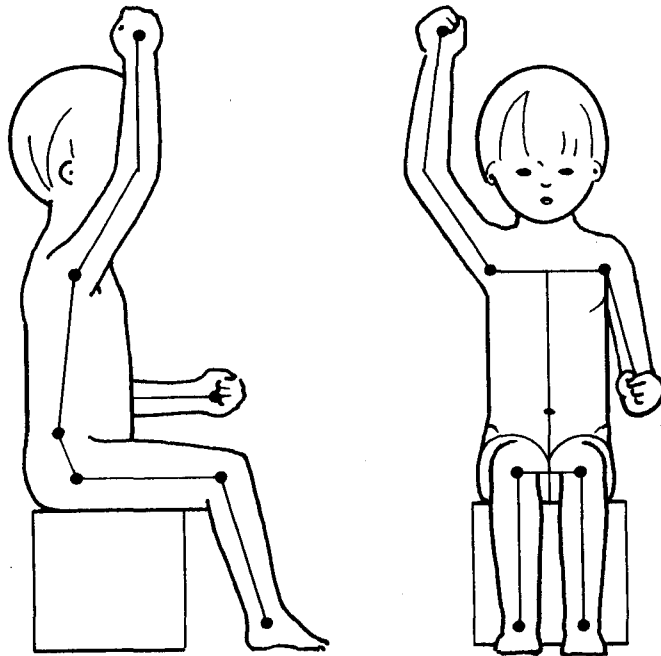

SI-4

B-3

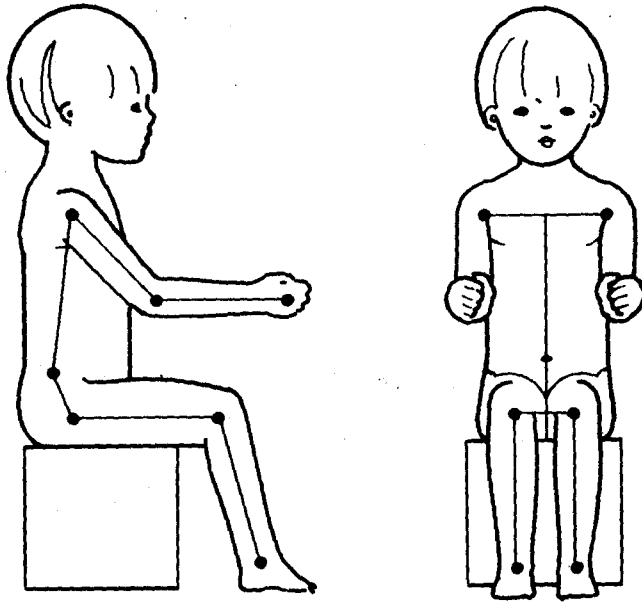

SI-5

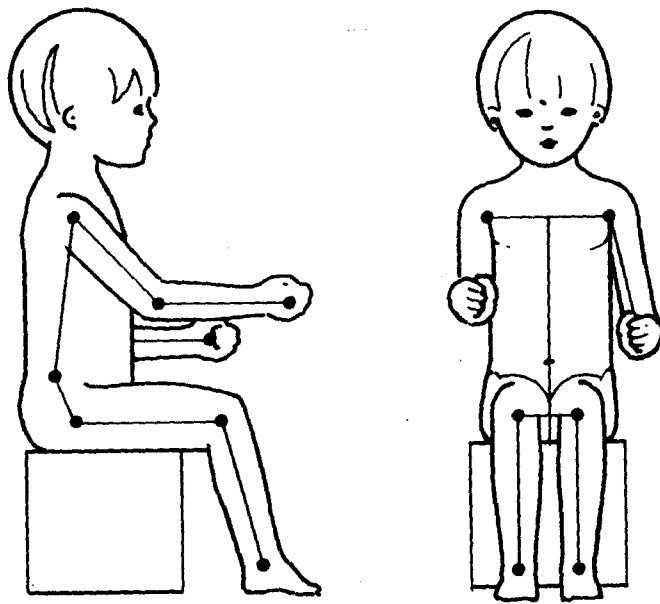

SI-6

B-4

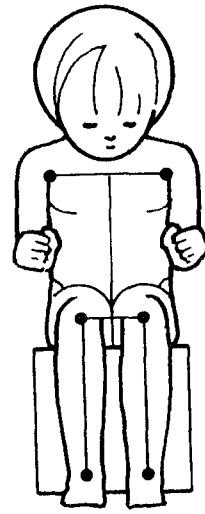
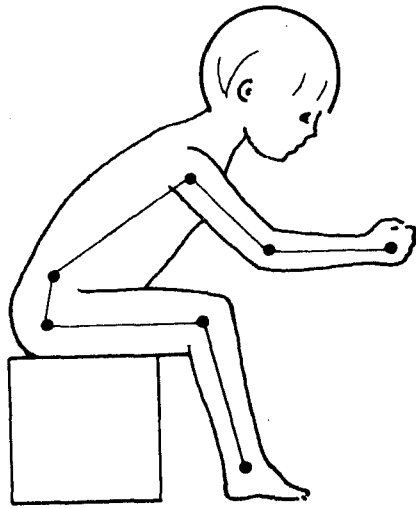

SI-7

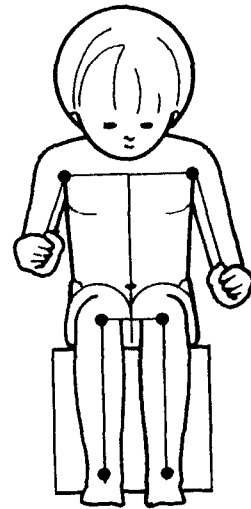
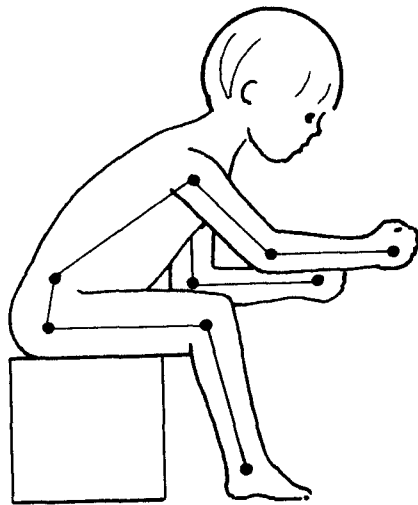

SI-8

B-5

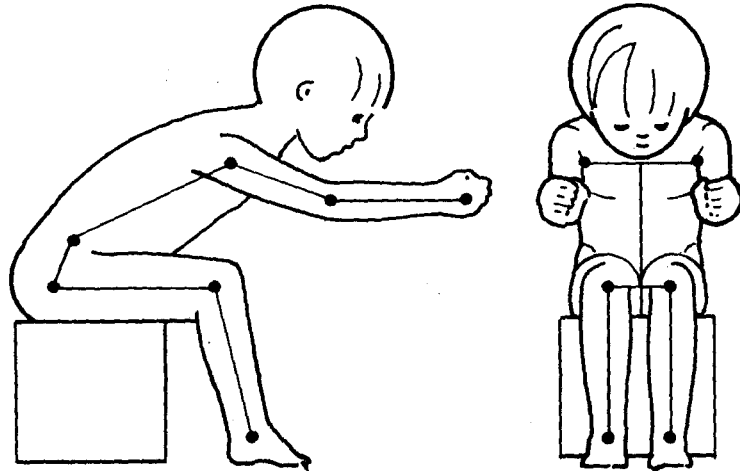

SI-9

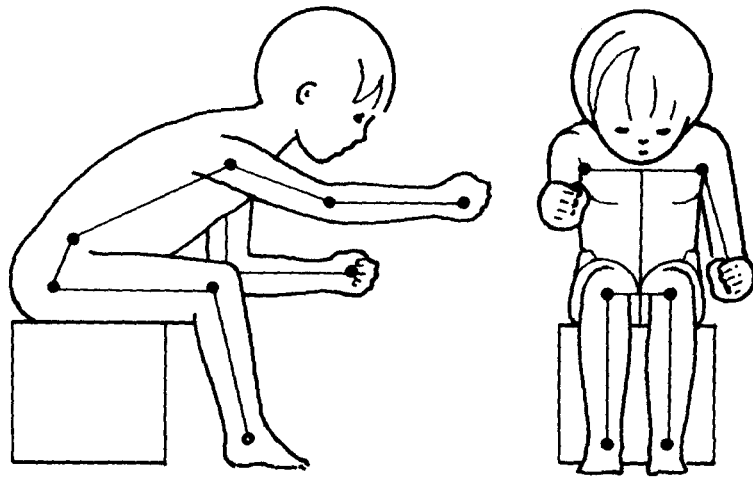

SI-10

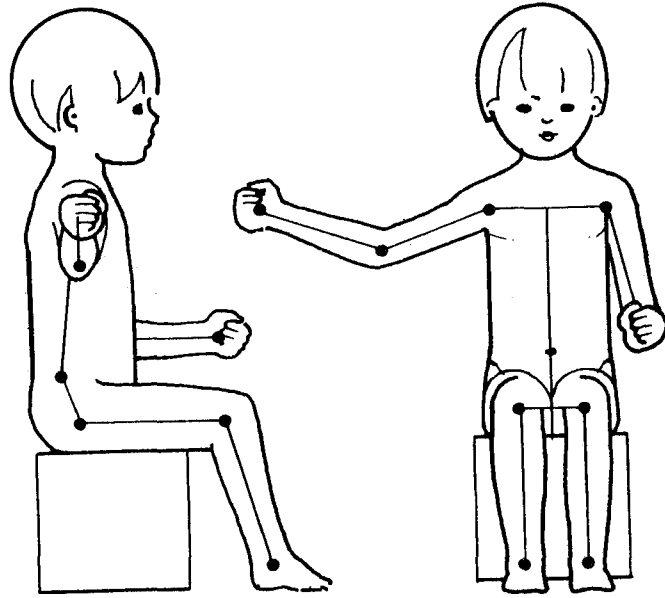

SI-11

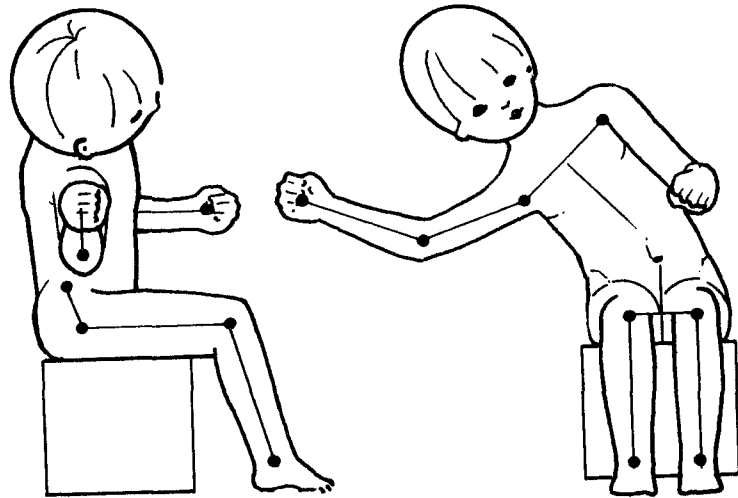

SI-12

B-7

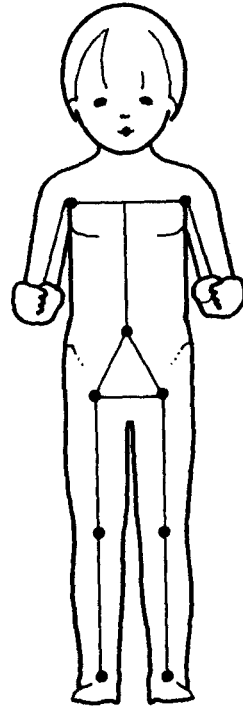
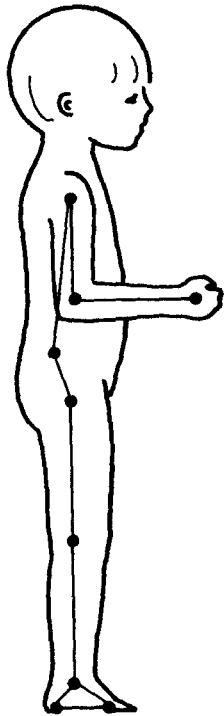

ST-1

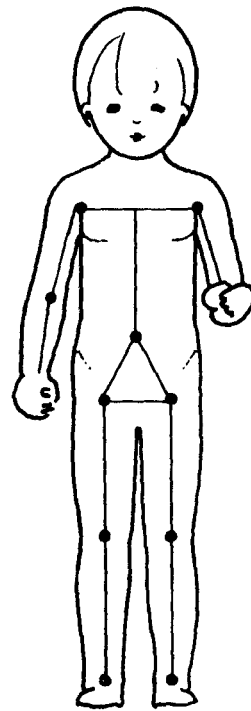
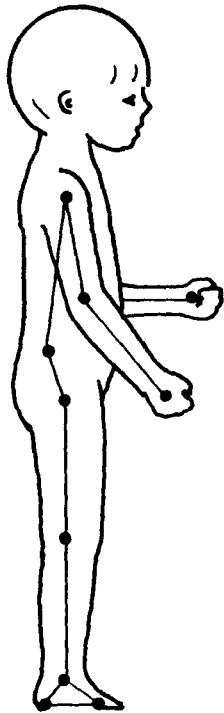

ST-2

B-8

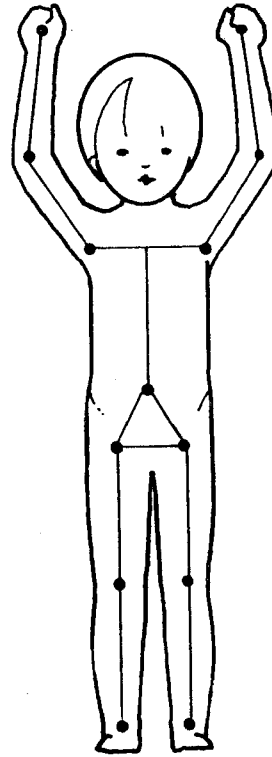
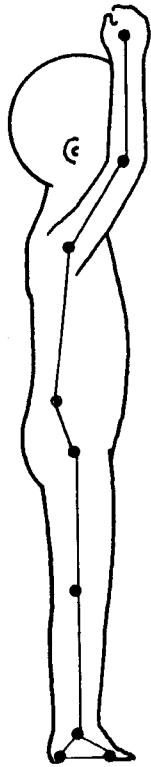

ST-3

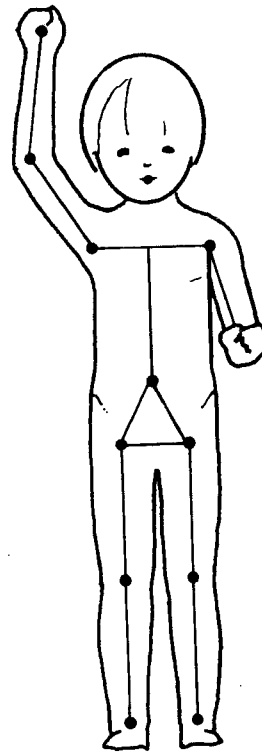
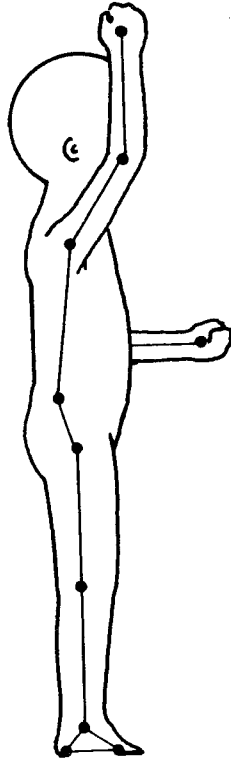

ST-4

B-9

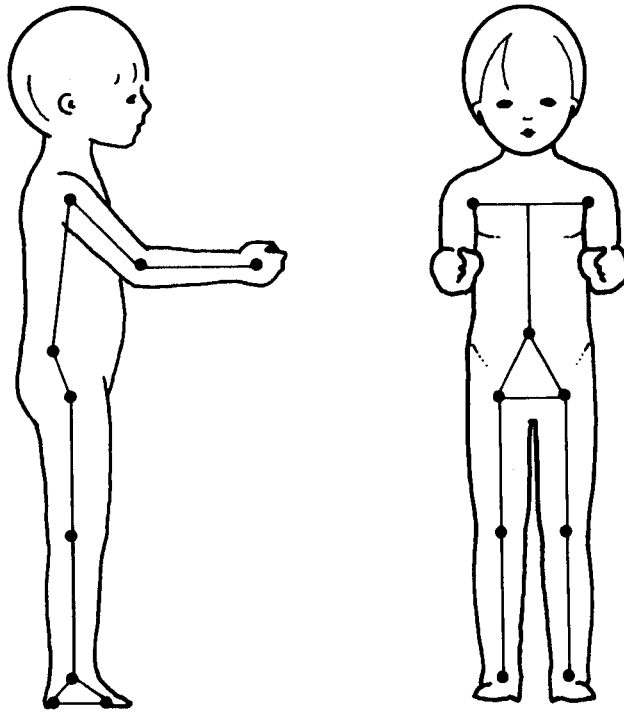

ST-5

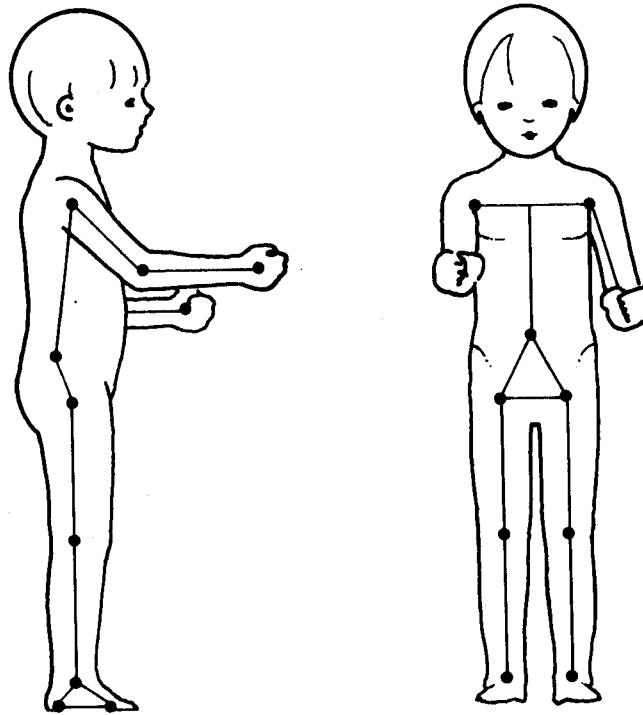

ST-6

B-10

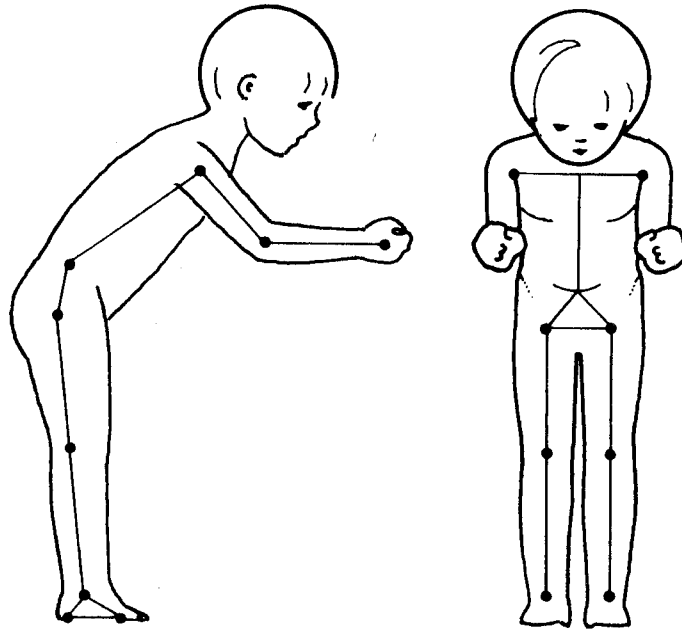

ST-7

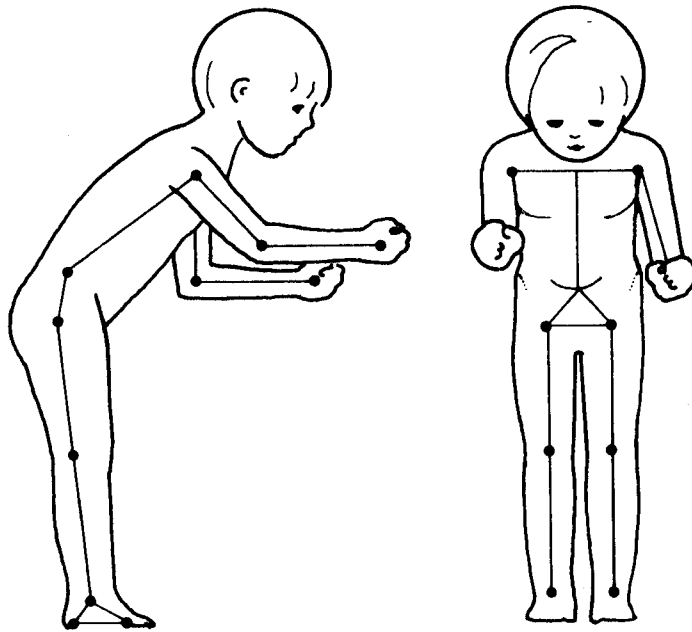

ST-8

B-11

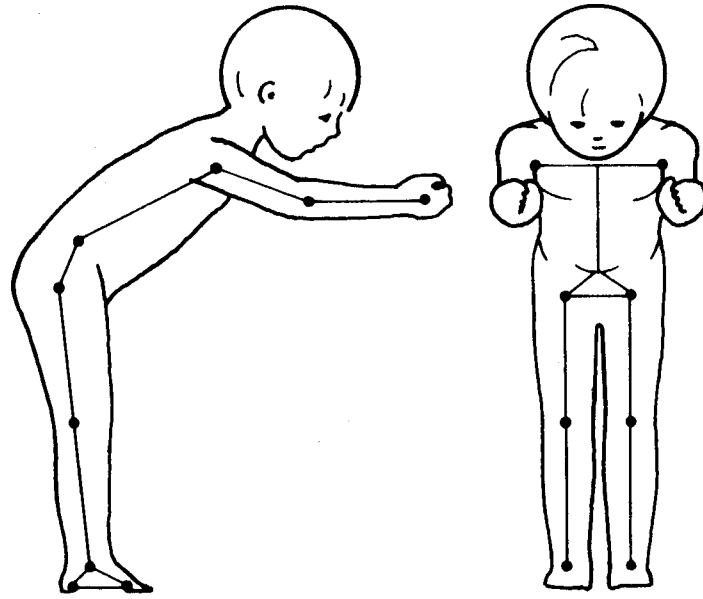

ST-9

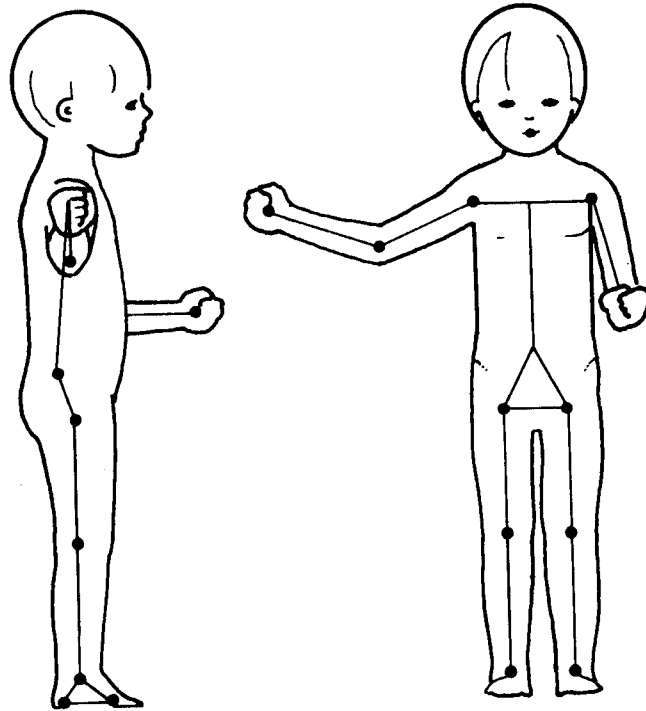

ST-10

B-12

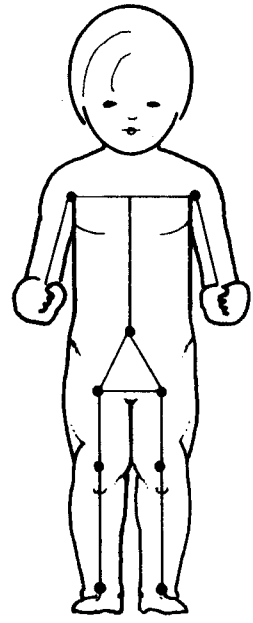
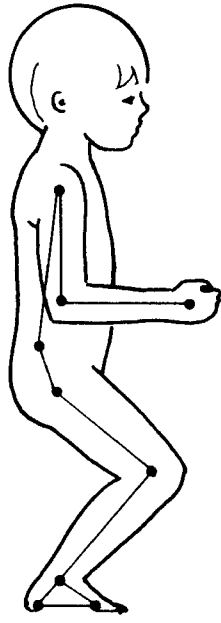

ST-11

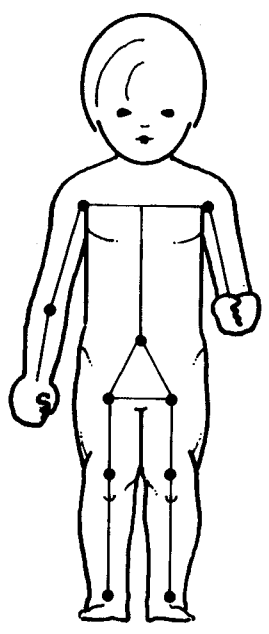
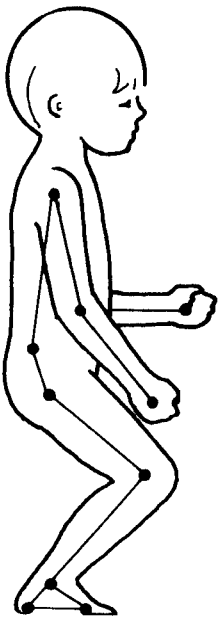

ST-12

B-13

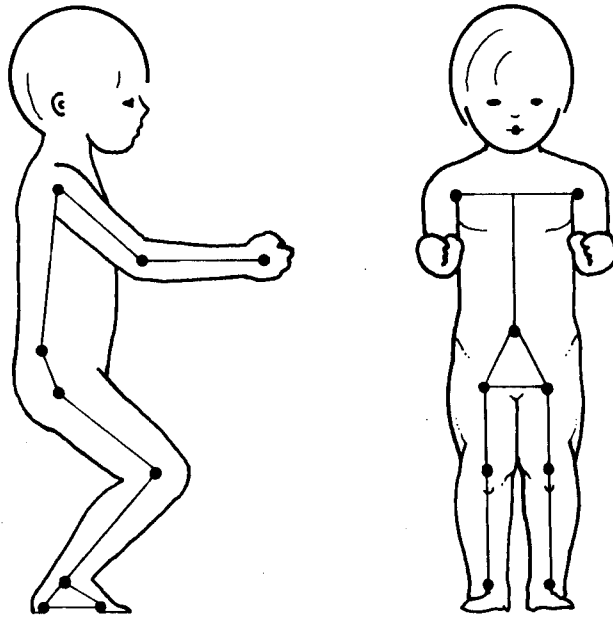

ST-13

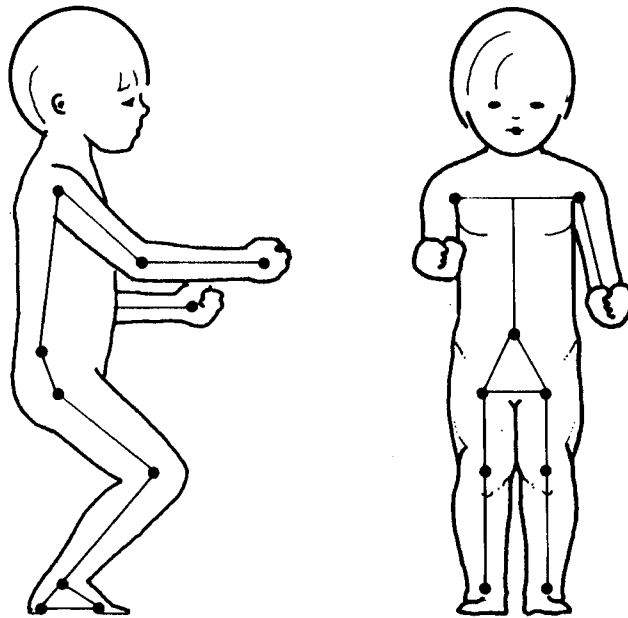

ST-14

B-14

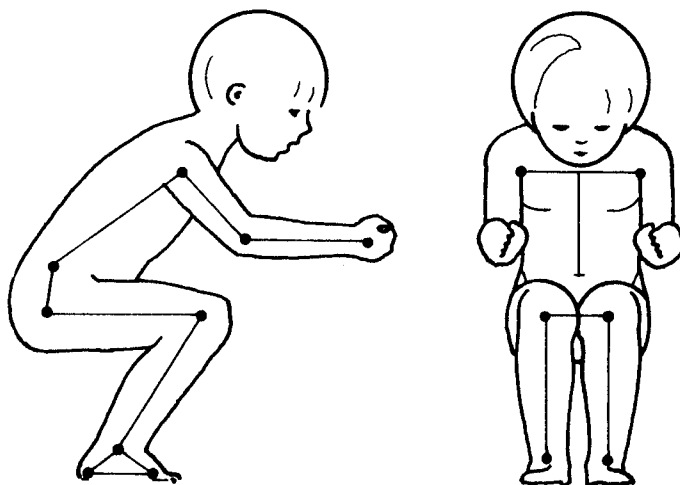

ST-15

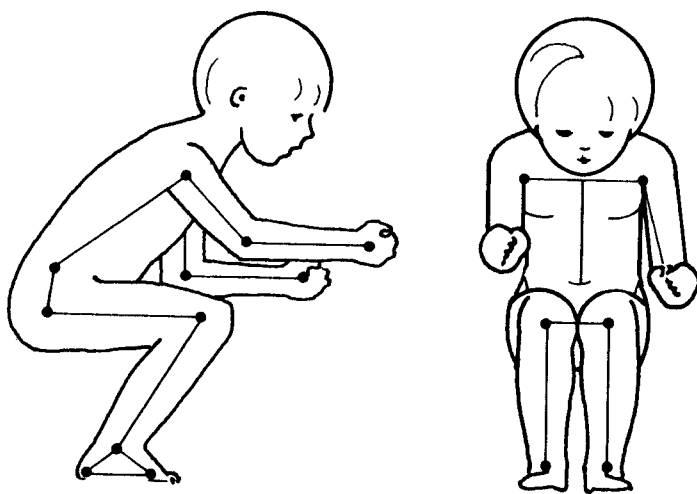

ST-16

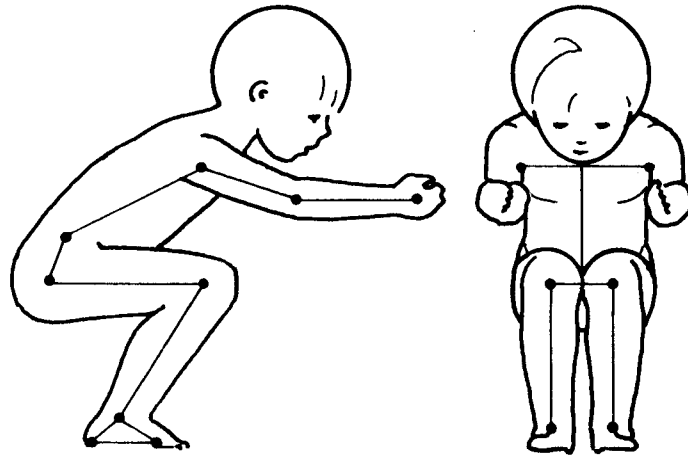

ST-17

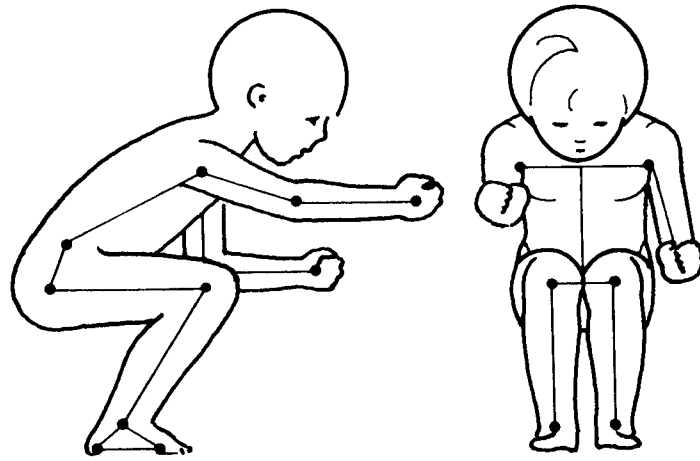

ST-18

FORCE DIRECTION CODES

Code #	Right Hand	Left Hand
1	Lift	Lift
2	Lift	-----*
3	Push Forward	Push Forward
4	Push Forward	-----*
5	Pull Back	Pull Back
6	Pull Back	-----*
7	Pull Towards Left	Pull Towards Left
8	Pull Towards Left	-----*
9	Pull Towards Right	Pull Towards Right
10	Pull Towards Right	-----*
11	Pull Down	Pull Down
12	Pull Down	-----*
13	Lift	Pull Down
14	Pull Towards Right	Pull Towards Left
15	Pull Towards Left	Pull Towards Right
16	Push Forward	Pull Back

*Left hand is free.

APPENDIX C
PROGRAM LOGIC

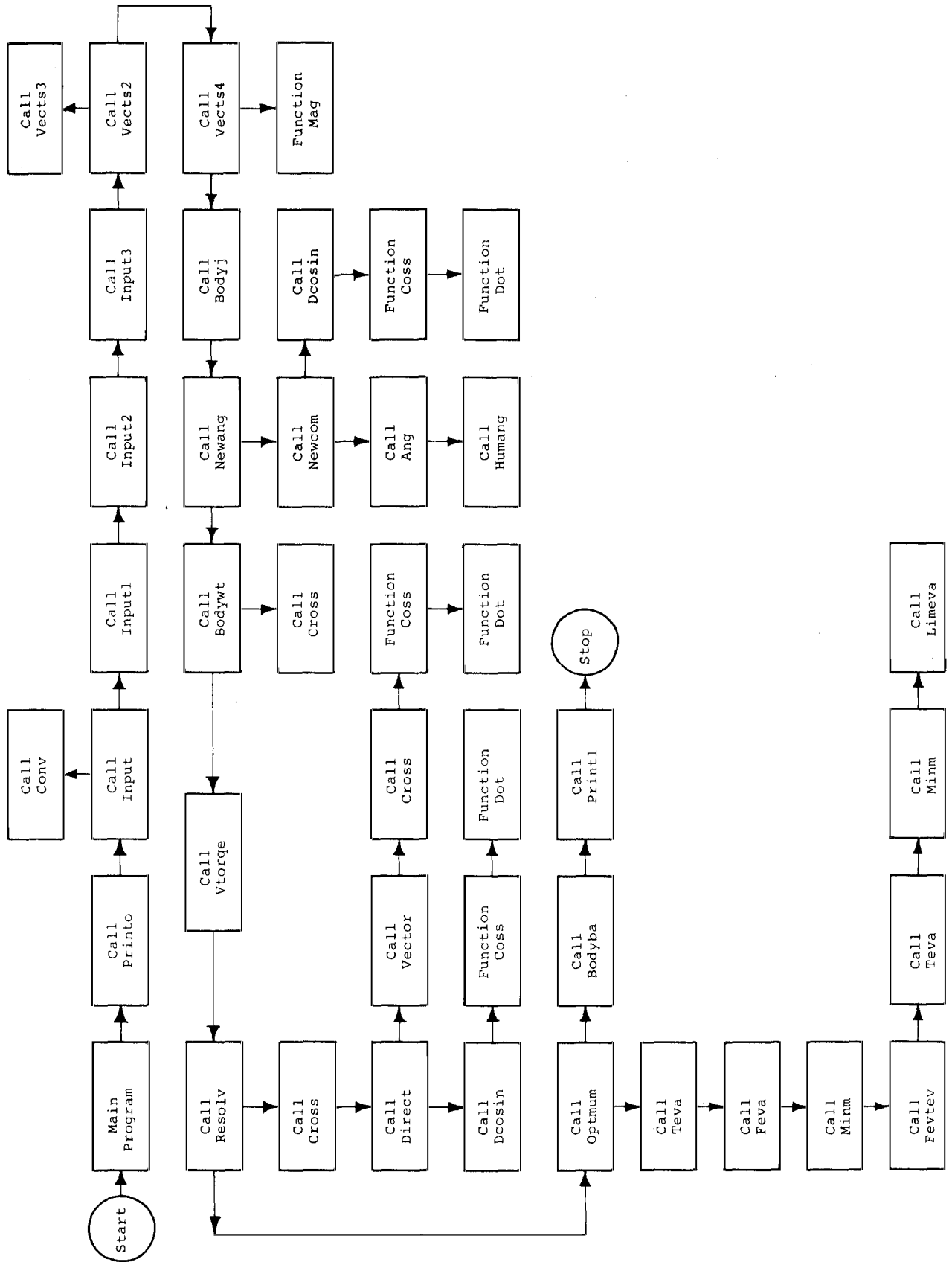

APPENDIX C

1. MAIN PROGRAM: This program controls the flow of the program and calls various subroutines.
2. Subroutine INPUT: This subroutine reads sex, age, percentile population, body position code and force direction code. It also sets all flags and initializes force direction angles.
3. Subroutine INPUT1: This subroutine reads all the body angles in degrees on I/O unit 1 and converts them into radians. Angles are stored in a line file.
4. Subroutine INPUT2: This subroutine reads body weight, height, wrist to center-of-grip, lower arm length, upper arm length, L₅/S₁ to shoulder height, hips to L₅/S₁ height, upper leg length, lower leg length, shoulder width, hip width and ankle to ball of foot horizontal distance. All the lengths are in inches and body weight is in lbs. I/O unit 2 is used for read and all the body dimensions and body weight are stored in a line file.
5. Subroutine INPUT3: This subroutine reads all the 20 subject strength coefficients on I/O unit 3. These strength coefficients are stored in a file. In addition this also sets the "left-right adjustment."
6. Subroutine VECTS2: This subroutine calculates the unit vectors between various body joints. In addition, this also sets standard X, Y, and Z axes and finds new axes with respect to trunk.
7. Subroutine VECTS3: Using Euler angle notations, this subroutine returns unit vector given the axis of rotation, body angles and sequence of rotation. This is called by subroutine VECTS2.
8. Subroutine VECTS4: Given body segment lengths and their direction (unit vectors), this subroutine calculates the vectors between body joints.
9. Subroutine NEWANG: This subroutine computes the shoulder vertical angle, shoulder horizontal angle and humeral rotation angle with respect to new axes rotated along the trunk. These new angles are used in computing voluntary torques for arms.

10. Subroutine NEWCOM: Given old and new set of axes and the components of a vector in the old system, this subroutine returns the components of the vector in the new axes system.
11. Subroutine ANG: Given the new upper arm vector, this subroutine computes new shoulder vertical and horizontal angles, i.e., new arm angles with respect to the trunk.
12. Subroutine HUMANG: Given new lower arm vector, new shoulder vertical, horizontal and elbow angles, this subroutine computes new humeral rotation angle.
13. Subroutine VTORQE: Given new body angles (in degrees) and subject strength coefficients, this subroutine computes maximum voluntary torques for both arms, legs and the torso.
14. Subroutine BODYWT: This subroutine computes weights of all the body limbs, their center of gravity and resultant torques due to the weights of these links at all the body joints. The body weight torques so calculated are in standard X,Y and Z system.
15. Subroutine RESOLV: This subroutine performs the following functions:
 - A. Compute resultant torques at all the body joints assuming unit forces acting at the hands. These are called unit force torques.
 - B. Determine new reference system for arms so that the resultant torques at the elbow and shoulder can be resolved to determine the components resulting in elbow flexion-extension, shoulder abduction-adduction, shoulder forward and backward rotation, and medial and lateral humeral rotation.
 - C. Resolve the unit force torques and body weight torques at the elbow and shoulder along the new reference system given in B.
16. Subroutine OPTMUM: This subroutine determines the maximum forces that can be sustained at all the body joints without exceeding the corresponding voluntary torques. It also computes the minimum of these maximum forces and stores the corresponding limiting muscle group.
17. Subroutine TEVA: Given body weight torques, unit force torques, hand forces and voluntary torques, this subroutine computes the resultant torques. It also determines if any muscle strength is exceeded by comparing the resultant torque with the corresponding voluntary torque.

18. Subroutine FEVA: Given body weight torque, unit force torque and voluntary torque, this evaluates maximum force that can be sustained at a given body joint without exceeding the corresponding voluntary torque.
19. Subroutine MINM: Given an array, this subroutine finds the minimum value and corresponding index.
20. Subroutine FEVTEV: This subroutine performs the following two functions:
 - A. Given body weight torques, unit force torques, hand forces and voluntary torques, this subroutine by calling TEVA evaluates if the voluntary torque has been exceeded, and if so,
 - B. This computes the maximum forces at the joint which can be sustained without exceeding the voluntary torque. In case of two handed exertions right and left hand forces are reduced in proportion to their magnitudes.

This subroutine is called by OPTMUM for evaluating maximum forces at the L₅/S₁, hip, knee and ankle joints.
21. Subroutine LIMEVA: This subroutine evaluates the new limiting factors and erases the old limiting factors.
22. Subroutine PRINT1: This subroutine prints the right and left hand forces and the limiting muscle groups.
23. Subroutine DCOSIN: Given old and new sets of axes, the subroutine computes the directional cosines between them.
24. Subroutine VECTOR: Given two points in space, subroutine VECTOR finds the vector from point one to point two.
25. Function COSS: Given two vectors, functions COSS returns the cosine of the angle between the two vectors.
26. Function MAG: Function MAG computes the magnitude of the given vector.
27. Function DOT: Given two vectors, function DOT returns the dot product of the two vectors.
28. Subroutine CROSS: Given two vectors, subroutine CROSS computes the cross product of the two vectors.
29. Subroutine DIRECT: Given shoulder to elbow and elbow to hand unit vectors, subroutine DIRECT finds three axes namely one along the lower arm, second axis in the plane of hand, elbow and shoulder but perpendicular to lower arm, and the third axis normal to this plane.

30. Subroutine CONV: Subroutine CONV converts the characters into numerical value.
31. Subroutine BODYJ: Given vectors from one body joint to another body joint, this subroutine calculates coordinates for all the body joints. The reference point is the middle point of the left and right ball of the foot.
32. Subroutine BODYBA: This subroutine performs the following functions:
 - A. To evaluate forward body balance.
 - B. To evaluate backward body balance.
 - C. To evaluate lateral body balance.If any of these body balances is lost, the right and left hand forces are reduced so that the body balance is maintained.
 - D. It also sets the upper limits on hand forces such that:
 - (i) for pull down, the hand forces cannot exceed the total body weight.
 - (ii) for push and pull forward, the maximum force cannot exceed the product of friction times the sum of body weight plus any hand forces acting in that direction.

APPENDIX B

```

>          LIST OF VARIABLES
>
>NOTATION
>I  INTEGER
>V  REAL
>A  ARRAY
>V  ARRAY OF DIMENSION 3
>ALL VARIABLES, ARRAYS AND ARRAYS OF DIMENSION THREE ARE REAL UNLESS
>SPECIFICALLY STATED TO BE INTEGER.
>VARIABLES ARE LISTED ACCORDING TO COMMON BLOCKS. IN THE END VARIABLES
>NOT COVERED UNDER COMMON BLOCKS ARE LISTED UNDER SUBROUTINES.
>VARIABLES THAT ARE NOT LISTED ARE DUMMY VARIABLES.
>
> NAME TYPE          DESCRIPTON
>*
>COMMON BLOCK FLAGS
>#SEX  I  SEX;1=MALE, 2=FEMALE, 3=UNISEX
>IPOS  I  POSITION; 1=SITTING, 2=STANDING
>ITYPE I  HANDED TYPE; 1=RIGHT HANDED, 2=LEFT HANDED
>IHAND I  NO. OF HANDS; 1=RIGHT HAND EXERTION, 2=BOTH HANDS EXEXTION
>POP   I  POPULATION,NOT USED IN THIS PROGRAM
>GRAV  I  GRAVITY
>*
>COMMON BLOCK FRCANG
>*
>LXANG R  FORCE ANGLE FROM X-AXIS(DEG.),LEFT HAND
>LZANG R  FORCE ANGLE FROM Z-AXIS(DEG.), LEFT HAND
>RXANG R  FORCE ANGLE FROM X-AXIS(DEG.), RIGHT HAND
>RZANG R  FORCE ANGLE FROM Z-AXIS(DEG.), RIGHT HAND
>LFMAG R  FORCE MAGNITUDE, LEFT HAND
>RFMAG R  FORCE MAGNITUDE, RIGHT HAND
>@COMMON BLOCK FDIR
>*
>FR    V  FORCE VECTOR, RIGHT HAND
>FL    V  FORCE VECTOR, LEFT HAND
>*
>COMMON BLOCK INPUTS
>#E    I  AGE OF THE SUBJECT
>IPOP  I  PERCENTILE POPULATION(10,50,90)
>POSNO I  POSITION # CODE
>*
>COMMON BLOCK COORDI
>*
```

>HANDR V HAND COORDINATES, RIGHT HAND
 >HANDL V HAND COORDINATES, LEFT HAND
 >ELBOWR V ELBOW COORDINATES, RIGHT ELBOW
 >ELBOWL V ELBOW COORDINATES, LEFT ELBOW
 >SHOULR V SHOULDER COORDINATES, RIGHT SHOULDER
 >SHOULL V SHOULDER COORDINATES, LEFT SHOULDER
 >T4 V T4(MIDDLE POINT OF SHOULDERS) COORDINATES
 >L5S1 V L5/S1 DISC COORDINATES
 >HIP V HIP(MIDDLE POINT OF HIPS) COORDINATES
 >HIPR V HIP COORDINATES, RIGHT HIP
 >HIPL V HIP COORDINATES, LEFT HIP
 >KNEER V KNEE COORDINATES, RIGHT KNEE
 >KNEEL V KNEE COORDINATES, LEFT KNEE
 >ANKLER V ANKLE COORDINATES, RIGHT ANKLE
 >ANKLEL V ANKLE COORDINATES, LEFT ANKLE
 >BFOOTR V BALL OF FOOT COORDINATE, RIGHT FOOT
 >BFOOTL V BALL OF FOOT COORDINATES, LEFT FOOT

>*

>COMMON BLOCK VECTS

>*

>EHRV V ELBOW TO HAND VECTOR, RIGHT ARM
 >EHLV V ELBOW TO HAND VECTOR, LEFT ARM
 >SERV V SHOULDER TO ELBOW VECTOR, RIGHT ARM
 >SELV V SHOULDER TO ELBOW VECTOR, LEFT ARM
 >L5SRV V L5/S1 TO SHOULDER VECTOR, RIGHT SHOULDER
 >L5SLV V L5/S1 TO SHOULDER VECTOR, LEFT SHOULDER
 >L5T4V V L5/S1 TO T4 VECTOR
 >HT4V V HIP TO T4 VECTOR
 >HL5V V HIP TO L5/S1 VECTOR
 >HL5RV V HIP TO L5/S1 VECTOR, RIGHT HIP
 >HL5LV V HIP TO L5/S1 VECTOR, LEFT HIP
 >KHRV V KNEE TO HIP VECTOR, RIGHT LEG
 >KHLV V KNEE TO HIP VECTOR, LEFT LEG
 >AKRV V ANKLE TO KNEE VECTOR, RIGHT LEG
 >AKLV V ANKLE TO KNEE VECTOR, LEFT LEG
 >T4SRV V T4 TO SHOULDER VECTOR, RIGHT SHOULDER
 >T4SLV V T4 TO SHOULDER VECTOR, LEFT SHOULDER
 >HTHR V VECTOR RIGHT HIP TO HIP
 >HTHL V VECTOR LEFT HIP TO HIP
 >BFTARV V BALL OF FOOT TO ANKLE VECTOR, RIGHT FOOT
 >BFTALV V BALL OF FOOT TO ANKLE VECTOR, LEFT FOOT

&#x00COMMON BLOCK UVECTS

>*

>ENTRIES IN THIS COMMON BLOCK ARE SAME AS THOSE IN THE COMMON BLOCK
 >VECTS EXCEPT THESE ARE UNIT VECTORS. 'UV' AT THE END OF A VARIABLE
 >STANDS FOR UNIT VECTOR. FOR EXAMPLE EHRUV IS THE SAME AS EHRV
 >EXCEPT FORMER IS THE UNIT VECTOR.

>&#x00COMMON BLOCK UVECTN

�THESE ARE ARM VECTORS WITH RESPECT TO REFERENCE SYSTEM LOCATED
 >ALONG TRUNK(XAXISN,YAXISN,ZAXISN).

>EHRUVN V ELBOW TO HAND UNIT VECTOR NEW, RIGHT ARM
 >EHLUVN V ELBOW TO HAND UNIT VECTOR NEW, LEFT ARM
 >SERUVN V SHOULDER TO ELBOW UNIT VECTOR NEW, RIGHT ARM
 >SELUVN V SHOULDER TO ELBOW UNIT VECTOR NEW, LEFT ARM

>*

>COMMON BLOCK SIZE

>*

>WEIGHT R TOTAL BODY WEIGHT(LBS.)
 >HEIGHT R STANDING STATURE(INCHES)
 >WCGHRM R WRIST TO CENTER OF GRIP OF HAND, RIGHT HAND
 >WCGHLM R WRIST TO CENTER OF GRIP OF HAND MAGNITUDE, LEFT HAND
 >EWRM R ELBOW TO WRIST MAGNITUDE, RIGHT ARM
 >EWLM R ELBOW TO WRIST MAGNITUDE, LEFT ARM
 >EHRM R ELBOW TO HAND MAGNITUDE, RIGHT ARM
 >EHLM R ELBOW TO HAND MAGNITUDE, LEFT ARM
 >SERM R SHOULDER TO ELBOW MAGNITUDE, RIGHT ARM
 >SELM R SHOULDER TO ELBOW MAGNITUDE, LEFT ARM
 >L5SRM R L5/S1 TO SHOULDER MAGNITUDE, RIGHT SHOULDER
 >L5SLM R L5/S1 TO SHOULDER MAGNITUDE, LEFT SHOULDER
 >L5T4M R L5/S1 TO T4 MAGNITUDE
 >HT4M R HIP TO T4 MAGNITUDE
 >HL5M R HIP TO L5/S1 MAGNITUDE
 >HL5RM R HIP TO L5/S1 MAGNITUDE, RIGHT HIP
 >HL5LM R HIP TO L5/S1 MAGNITUDE, LEFT HIP
 >KHRM R KNEE TO HIP MAGNITUDE, RIGHT LEG
 >KHLM R KNEE TO HIP MAGNITUDE, LEFT LEG
 >AKRM R ANKLE TO KNEE MAGNITUDE, RIGHT LEG
 >AKLM R ANKLE TO KNEE MAGNITUDE, LEFT LEG
 >STOOSM R SHOULDER TO SHOULDER MAGNITUDE(SHOULDER WIDTH)
 >HTOHM R HIP TO HIP MAGNITUDE(HIP WIDTH)
 >ABFM R ANKLE TO BALL OF FOOT MAGNITUDE(HORIZONTAL DISTANCE)

>*

>COMMON BLOCK BWTS

>WHAND R WEIGHT OF HAND
 >WLA R WEIGHT OF LOWER ARM(LBS.)
 >WUA R WEIGHT OF UPPER ARM(LBS.)
 >WL5H R WEIGHT OF TRUNK AND HEAD ABOVE L5/S1 DISC(LBS.)
 >WHL5 R WEIGHT OF TRUNK BETWEEN HIPS AND L5/S1(LBS.)
 >WUL R WEIGHT OF UPPER LEG(LBS.)
 >WLL R WEIGHT OF LOWER LEG(LBS.)

&#64;COMMON BLOCK AXES

>* , Y , Z AXES ARE DEFINED WHEN THE SUBJECT IS STANDING STRAIGHT
 >WITH HANDS STRETCHED TO THE SIDE.
 >XAXIS V XAXIS, ALONG RIGHT HAND
 >YAXIS V YAXIS, PERPENDICULAR TO X-AXIS IN HORIZONTAL PLANE
 >ZAXIS V Z-AXIS, PERPENDICULAR TO X & Y AXES IN SAGITTAL PLANE
 >XAXISN V X-AXIS NEW, AXIS FROM LEFT SHOULDER TO RIGHT SHOULDER
 >YAXISN V Y-AXIS NEW, AXIS PERPENDICULAR & INFRONT OF TRUNK
 >ZAXISN V Z-AXIS NEW, AXIS FROM L5/S1 TO T4

>*

>COMMON BLOCK ANGLS

S*AR R SHOULDER VERTICAL ANGLE(DEG.), RIGHT SHOULDER
 >SHAR R SHOULDER HORIZONTAL ANGLE(DEG.), RIGHT SHOULDER
 >HUMAR R HUMERAL ROTATION ANGLE(DEG.), RIGHT ARM
 >ELBAR R ELBOW ANGLE (DEG.), RIGHT ARM
 >FOREAR R FOREARM ROTATION ANGLE (DEG), RIGHT ARM
 >KNEEAR R KNEE ANGLE (DEG), RIGHT LEG
 >ANKAR R ANKLE ANGLE (DEG), LEFT LEG
 >SVAL R SHOULDER VERTICAL ANGLE, LEFT SHOULDER
 >SHAL R SHOULDER HORIZONTAL ANGLE, LEFT SHOULDER
 >HUMAL R HUMERAL ROTATION ANGLE, LEFT ARM
 >ELBAL R ELBOW ANGLE, LEFT ARM
 >FOREAL R FOREARM ROTATION ANGLE, LEFT ARM
 >KNEEAL R KNEE ANGLE, LEFT LEG
 >ANKAL R ANKLE ANGLE, LEFT LEG
 >TRFA R TRUNK FLEXION ANGLE (DEG.)
 >TRRA R TRUNK ROTATION ANGLE (DEG.)
 >TRBA R TRUNK LATERAL BENDING ANGLE (DEG.)
 >PELVA R PELVIC ANGLE (DEG.)
 >HIPA R HIP ANGLE (DEG.), TRUNK ANGLE AT HIPS
 >HIPAR R HIP ANGLE (DEG.) WITH RESPECT TO RIGHT THIGH
 >HIPAL R HIP ANGLE (DEG.) WITH RESPECT TO LEFT THIGH

>*

>COMMON BLOCK NANGLS

>*

>SVARN R RIGHT SHOULDER VERTICAL ANGLE IN NEW REFERENCE SYSTEM
 >SHARN R RIGHT SHOULDER HORIZONTAL ANGLE IN NEW REFERENCE SYSTEM
 >HUMARN R RIGHT HUMERAL ROTATION ANGLE IN NEW REFERENCE SYSTEM
 >SVALN R LEFT SHOULDER VERTICAL ANGLE IN NEW REFERENCE SYSTEM (RAD.)
 >SHALN R LEFT SHOULDER HORIZONTAL ANGLE IN NEW REFERENCE SYSTEM (RAD
 *.)
 >HUMALN R LEFT HUMERAL ROTATION ANGLE (RAD.) IN NEW REFERENCE SYSTEM

>*

>COMMON BLOCK STRCOF

>@0EF A(20) SUBJECT STRENGTH COEFFICIENTS IN INCH-LBS. BODY POSITION IS
 > SVAR=-85., SHAR=90., ELBAR=90., HUMAR=0., HIP=95, TRRA=0.,
 > TRBA=0., KNEEAR=180. & ANKAR=90.
 > 1=ELBOW EXTENSION; 2=ELBOW FLEXION; 3=HUMERAL ROTATION
 > MEDIAL; 4=HUMERAL ROTATION LATERAL; 5=SHOULDER ABDUCTION;
 > 6=SHOULDER ADDUCTION; 7=HORIZONTAL SHOULDER ROTATION BACK;
 > 8=HORIZONTAL SHOULDER ROTATION FORWARD; 9=TRUNK FORWARD
 > FLEXION; 10=TRUNK EXTENSION; 11=TRUNK LATERAL BENDING TO
 > THE LEFT; 12=TRUNK LATERAL BENDING TO THE RIGHT; 13=TRUNK
 > ROTATION TO THE RIGHT; 14=TRUNK ROTATION TO THE LEFT;
 > 15=HIP EXTENSION; 16=HIP FLEXION; 17=KNEE FLEXION;
 > 18=KNEE EXTENSION; 19=ANKLE FLEXION 20=ANKLE EXTENSION
 >COEFR R LEFT-RIGHT ADJUSTMENT FOR RIGHT ARM
 >COEFL R LEFT-RIGHT ADJUSTMENT FOR LEFT ARM
 >COEFFR A(4) ELBOW FLEXION-EXTENSION COEFFICIENTS AS A FUNCTION OF
 > FORE ARM ROTATION. 1=RIGHT ELBOW EXTENSION; 2=RIGHT
 > ELBOW FLEXION; 3=LEFT ELBOW EXTENSION; 4=LEFT ELBOW
 > FLEXION.

@COMMON BLOCK VOLTOR

>*

```

>VTORQ A(6) VOLUNTARY TORQUES FOR TRUNK (IN-LBS.) NAMELY,TRUNK
> FLEXION, EXTENSION, LATERAL BENDING LEFT, LATERAL
> BENDING RIGHT, TRUNK ROTATION TO THE RIGHT & LEFT
>VTORQR A(14) VOLUNTARY TORQUES FOR RIGHT ARM AND LEG (IN-LBS)
> NAMELY, ELBOW FLEXION, EXTENSION, HUMERAL ROTATION
> MEDIAL, LATERAL, SHOULDER ABDUCTION, ADDUCTION, HOR.
> SHOULDER ROTATION BACK, FORWARD, HIP EXTENSION, FLEXION,
> KNEE FLEXION, EXTENSION, ANKLE FLEXION & EXTENSION
>VTORQL A(14) VOLUNTERY TORQUES FOR LEFT ARM &LEG (IN-LBS.).
> 1=ELBOW FLEXION; 2=EXTENSION; 3=HUMERAL ROTATION LATERAL
> 4=MEDIAL; 5=SHOULDER ABDUCTION; 6=ADDUCTION; 7=HOR.
> SHOULDER ROTATION FORWARD; 8=BACKWARD; 9=HIP EXTENSION;
> 10=HIP FLEXION; 11=KNEE FLEXION; 12=EXTENSION; 13=ANKLE
> FLEXION; 14=EXTENSION
>BACLIM I BACK LIMIT, NOT USED IN THIS PROGRAM
COMMON BLOCK BWTORQ
>*
>ALL THE BODY WEIGHT TORQUES IN THIS COMMON BLOCK ARE WITH REFERENCE
>TO STANDARD X,Y,Z REFERENCE SYSTEM AND UNITS ARE INCH-LBS.
>BWTELR V BODY WEIGHT TORQUE, ELBOW RIGHT
>BWTELL V BODY WEIGHT TORQUE, ELBOW LEFT
>BWTSHR V BODY WEIGHT TORQUE, SHOULDER RIGHT
>BWTSHL V BODY WEIGHT TORQUE, SHOULDER LEFT
>BWTLSR V BODY WEIGHT TORQUE AT L5/S1 DUE RIGHT ARM WEIGHT
>BWTLSL V BODY WEIGHT TORQUE AT L5/S1 DUE TO LEFT ARM WEIGHT
>BWTLS V TOTAL BODY WEIGHT TORQUE AT L5/S1
>BWTHR V BODY WEIGHT TORQUE, HIP RIGHT
>BWTHL V BODY WEIGHT TORQUE, HIP LEFT
>BWTKR V BODY WEIGHT TORQUE, KNEE RIGHT
>BWTKL V BODY WEIGHT TORQUE, KNEE LEFT
>BWTAR V BODY WEIGHT TORQUE, ANKLE RIGHT
>BWTAL V BODY WEIGHT TORQUE, ANKLE LEFT
COMMON BLOCK BWTN
>*
>THIS BLOCK HAS BODY WEIGHT TORQUES AT ELBOW AND SHOULDER AFTER
>BEING RESOLVED IN SUBROUTINE RESOLV SUCH THAT THEY CAN BE
>COMPARED WITH VOLUNTARY TORQUES TO EVALUATE ELBOW AND SHOULDER
>MUSCLES. UNITS ARE IN-LBS.
>BWTERN V BODY WEIGHT TORQUE ELBOW RIGHT NEW.
>BWTELN V BODY WEIGHT TORQUE ELBOW LEFT NEW
>BWTSRN V BODY WEIGHT TORQUE SHOULDER RIGHT NEW
>BWTSLN V BODY WEIGHT TORQUE SHOULDER LEFT NEW
COMMON BLOCK UFT
>*

```

>THIS BLOCK HAS UNIT FORCE TORQUES FOR ALL THE BODY JOINTS AFTER BEING
>RESOLVED IN SUBROUTINE RESOLV. UNITS ARE INCH-LBS. VARIABLES ARE:

>UFTER V UNIT FORCE TORQUE, ELBOW RIGHT
>UFTEL V , ELBOW LEFT
>UFTSR V UNIT FORCE TORQUE, SHOULDER RIGHT
>UFTSL V UNIT FORCE TORQUE, SHOULDER LEFT
>UFTL5R V UNIT FORCE TORQUE AT L5/S1 DUE TO RIGHT HAND FORCE
>UFTL5L V UNIT FORCE TORQUE AT L5/S1 DUE TO LEFT HAND UNIT FORCE
>UFTHRR V UNIT FORCE TORQUE AT RIGHT HIP DUE TO UNIT RIGHT HAND FORCE
>UFTHRL V UNIT FORCE TORQUE AT RIGHT HIP DUE TO UNIT LEFT HAND FORCE
>UFTHLL V UNIT FORCE TORQUE AT LEFT HIP DUE TO UNIT LEFT HAND FORCE
>UFTHLR V UNIT FORCE TORQUE AT LEFT HIP DUE TO UNIT RIGHT HAND FORCE
>UFTKRR V UNIT FORCE TORQUE AT RIGHT KNEE DUE TO UNIT RIGHT HAND FORC
*UFTKRL V UNIT FORCE TORQUE AT RIGHT KNEE DUE TO UNIT LEFT HAND FORCE
>UFTKLL V UNIT FORCE TORQUE AT LEFT KNEE DUE TO UNIT LEFT HAND FORCE
>UFTKLR V UNIT FORCE TORQUE AT LEFT KNEE DUE TO UNIT RIGHT HAND FORCE
>UFTARR V UNIT FORCE TORQUE AT RIGHT ANKLE DUE TO UNIT RIGHT HAND FOR
*CE
>UFTARL V UNIT FORCE TORQUE AT RIGHT ANKLE DUE TO UNIT LEF HAND FORC
*UFTALL V UNIT FORCE TORQUE AT LEFT ANKLE DUE TO UNIT LEFT HAND FORCE
>UFTALR V UNIT FORCE TORQUE AT LEFT ANKLE DUE TO UNIT RIGHT HAND FORC
*U
>COMMON BLOCK LIMITS
>*>
>LIMFA I 0=TRUNK VOLUNTARY TORQUES HAVE NOT BEEN EXCEEDED.
> 1=TRUNK FLEXION STRENGTH HAS BEEN EXCEEDED
> 2=TRUNK EXTENSION
> 3=TRUNK LATERAL BENDING TO THE LEFT
> 4=TRUNK LATERAL BENDING TO THE RIGHT
> 5=TRUNK ROTATION TO THE RIGHT
> 6=TRUNK ROTATION TO THE LEFT
>LIMFAR I 0=RIGHT ARM AND LEG VOLUNTARY TORQUES HAVE NOT BEEN EXCEEDE
*U,
> OTHERWISE FOLLOWING LIMITS HAVE BEEN EXCEEDED
> 1=ELBOW FLEXION
> 2=ELBOW EXTENSION
> 3=HUMERAL ROTATION MEDIAL; 4=HUMERAL ROTATION LATERAL
> 5=SHOULDER ABDUCTION; 6=SHOULDER ADDUCTION
> 7=HORIZONTAL SHOULDER ROTATION BACK; 8=FORWARD
> 9=HIP EXTENSION; 10=HIP FLEXION; 11=KNEE FLEXION; 12=KNEE
> EXTENSION; 13=ANKLE FLEXION; 14=ANKLE EXTENSION
>LIMFAL I 0=VOLUNTARY TORQUES HAHE NOT BEEN EXCEEDED ON LEFT ELBOW
> , SHOULDER, AND LEG
> 1=ELBOW FLEXION; 2=ELBOW EXTENSION; 3=HUMERAL ROTATION LATER
*AL;
> 4=HUMERAL ROTATION MEDIAL; 5=SHOULDER ABDUCTION; 6=SHOULDER
> ADDUCTION; 7=HORIZONTAL SHOULDER ROTATION FORWARD; 8=BACKWAR
*U;

```

>          9-12 ARE SAME AS LIMFAR EXCEPT FOR THE LEFT LEG
>IBACK  I      NOT USED IN THIS PROGRAM
>IFALL  I      =0 BODY BALANCE IS MAINTAINED
>          1=FORWARD BODY BALANCE IS LOST
>          2=BACKWARD BODY BALANCE IS LOST
>          3=LATERAL BODY BALANCE IS LOST TO THE RIGHT
>          4=LATERAL BODY BALANCE IS LOST TO THE LEFT
>FORCER R      RIGHT HAND FORCE MAGNITUDE (LBS.)
>FORCEL R      LEFT HAND FORCE MAGNITUDE (LBS.)
>*
>COMMON BLOCK CGLINK
THIS BLOCK HAS VARIABLES AS FRACTION OF LINK LENGTHS. FOR EXAMPLE
>FRACTION OF LOWER ARM ETC.
>PECGLA R      ELBOW TO CG OF LOWER ARM
>PSCGUA R      SHOULDER TO CG OF UPPER ARM
>PCGL5H R      L5/S1 TO CG OF TRUNK ABOVE L5/S1 AND HEAD
>PCGHL5 R      HIP TO CG OF TRUNK MASS BETWEEN HIPS AND L5/S1
>PKCGUL R      KNEE TO CG OF UPPER LEG
>PACGLL R      ANKLE TO CG OF LOWER LEG
>*
>COMMON BLOCK RESTOR
>*
>THIS BLOCK STORES THE RESULTANT TORQUE VALUES IN INCH-LBS AT
>ELBOWS, SHOULDERS, L5/S1, HIPS, KNEES AND ANKLES.
>RTORQ  A(6)   RESULTANT TORQUES AT L5/S1. INDECES MEAN THE SAME AS
>          IN VTORQ
>RTORQR A(14)  RESULTANT TORQUES FOR RIGHT ARM AND LEG. INDECES
>          MEAN THE SAME AS IN VTORQR.
>RTORQL A(14)  RESULTANT TORQUES FOR LEFT ARM AND LEG. INDECES
>          MEAN THE SAME AS IN VTORQL
>*
>COMMON BLOCK ERRORS
>*
>ERROR  I      1=NO ERROR
>          2=ERROR IN THE PROGRAM CALLED
>*
>*SUBROUTINE INPUT
>*ANGR  A(16)  STORES ANGLES FROM X-AXIS FOR RIGHT HAND FORCE EXERTIONS
>XANGL  A(16)  STORES ANGLES FROM X-AXIS FOR LEFT HAND FORCE EXERTION
>ZANGR  A(16)  STORES ANGLES FROM Z-AXIS FOR RIGHT HAND FORCE EXERTIONS
>ZANGL  A(16)  STORES ANGLES FROM Z-AXIS FOR LEFT HAND FORCE EXERTIONS
>NHANDS A(16)  INTEGER, STORES NO. OF HANDS IN THE PARTICULAR EXERTION,
>          1=RIGHT HAND ONLY; 2=BOTH HANDS.

```

SUBROUTINE RESOLV

```

>★AXISR1 V      AXIS ALONG THE LOWER ARM OF RIGHT HAND
>AXISR2 V      AXIS NORMAL TO THE PLANE FORMED BY RIGHT HAND, ELBOW &
>                SHOULDER
>AXISR3 V      AXIS PERPENDICULAR TO AXISR1 &AXISR2
>AXISL1 V      AXIS ALONG THE LOWER ARM OF THE LEFT HAND
>AXISL2 V      AXIS NORMAL TO THE PLANE FORMED BY LEFT HAND, ELBOW &
>                SHOULDER
>AXISL3 V      AXIS PERPENDICULAR TO AXISL1 & AXISL2
>DCR1  A(9)    DIRECTION COSINES FOR LOWER ARM RIGHT
>DCR2  A(9)    DIRECTION COSINES FOR UPPER ARM RIGHT
>DCL1  A(9)    DIRECTION COSINES FOR LOWER ARM LEFT
>DCL2  A(9)    DIRECTION COSINES FOR UPPER ARM LEFT
>EHRV90 V     ELBOW TO HAND VECTOR WHEN ELBAR=90 & HUMAR=90
>EHLV90 V     ELBOW TO HAND VECTOR FOR LEFT ARM WHEN ELBAL=90 & HUMAL=90
>RTER  V      UNIT FORCE TORQUES IN X,Y,Z SYSTEM AT RIGHT ELBOW
>RTEL  V      UNIT FORCE TORQUES IN STANDARD X,Y,Z SYSTEM AT LEFT ELBOW
>RTSR  V      UNIT FORCE TORQUES IN STANDARD X,Y,Z SYSTEM AT RIGHT SHOULDE
★ER
>RTSL  V      UNIT FORCE TORQUES IN STANDARD X,Y,Z SYSTEM AT LEFT SHOULDE
★R
ROUTINE BODYBA
>★
>FRCTON R     COEFFICIENT OF FRICTON
#

```